



# Conserver® XL

Project \_\_\_\_\_

Item \_\_\_\_\_

Quantity \_\_\_\_\_

CSI Section 11400

Approval \_\_\_\_\_

Date \_\_\_\_\_

Conserver® XL

## Models

Conserver® XL



### Standard Features

- Electromechanical control
- Built in waste accumulator
- 3" (76 mm) stainless steel adjustable bullet feet
- Delimer switch for easy removal of hard water deposits
- Removable scrap screen
- Air gap instead of vacuum breaker
- Door safety switch
- Convenient top mounted controls
- Auto start
- Interchangeable upper and lower stainless steel wash/rinse arms
- Wash/rinse thermometer
- Low product indicator light

### Mandatory Specs

Specify voltage \_\_\_\_\_

### Options

- 50Hz Cycle
- Water Hammer Arrestor
- Scaltrol
- False Panel
- Flanged Feet
- Audible Low Product Alarm

## Specifications

Uses 1.5 gallons (6 liters) water per rack

37 racks per hour

Single point electrical connection

Self-draining stainless steel pump eliminates soil/detergent carryover between wash and rinse cycles

Dump and fill feature disposes of dirty water, replacing it with a fresh water rinse every cycle

Field convertible from straight to corner and corner to straight for flexible installations and applications

Dual-point drain connections allow for versatile installations

17-1/4" (438 mm) vertical inside clearance

3 built-in dispensing pumps for detergent, rinse agent and sanitizer are controlled by individual priming switches

Large removable scrap screen

Heavy duty stainless steel construction





# Conserv<sup>®</sup> XL

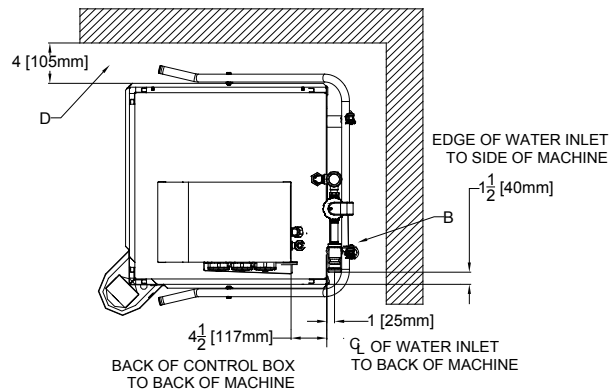
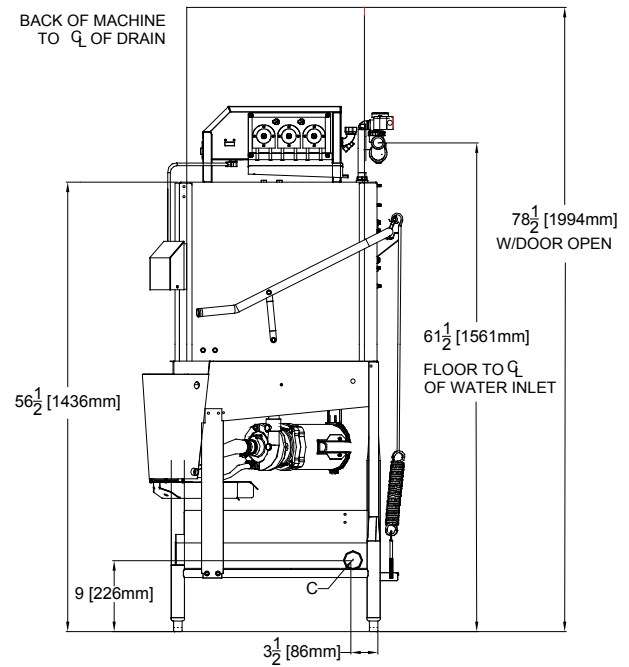
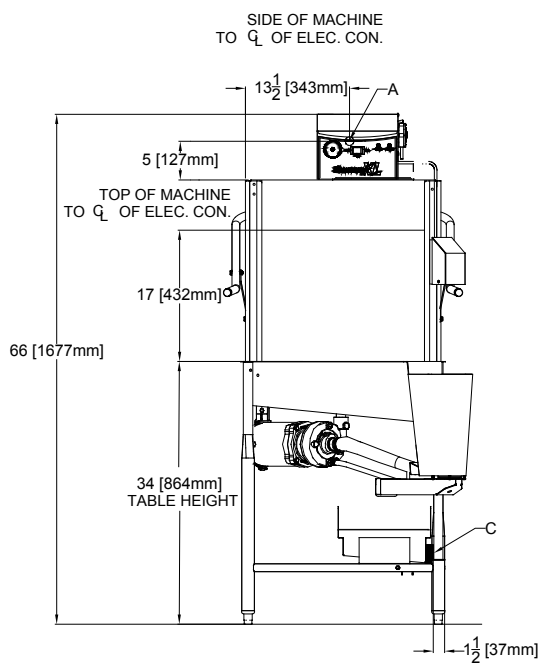

**LEGEND**  
 A - ELECTRICAL CONNECTION  
 B - WATER INLET, 3/4" IPS  
 C - DRAIN CONNECTION, 2" IPS  
 D - STANDARD CLEARANCE BETWEEN MACHINE AND WALL (WITH DISHTABLE) IS 4" [105mm]

All dimensions are +/- 1/2" from floor due to adjustable bullet feet

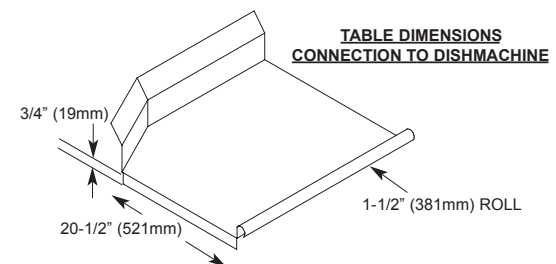

MODEL NO.	MACHINE DIMENSIONS				DRAIN HEIGHT	SHIPPING INFORMATION					
	HEIGHT	WIDTH	WIDTH BETWEEN DISHTABLES	DEPTH		WEIGHT	CLASS	CUBE	HEIGHT	WIDTH	DEPTH
Conserv <sup>®</sup> XL	68-1/2" (1740 mm)	33" (838 mm)	25-1/4" (641 mm)	32-3/4" (832 mm)	9" (229 mm)	280 lbs (127 kg)	92.5	64.9 cu. ft.	79" (2007 mm)	33" (838 mm)	43" (1092 mm)

POWER REQUIREMENTS	
Model	Conserv <sup>®</sup> XL
Electrical Requirement	115v/60~1ø-11.4A
Service Breaker Size	15A

PERFORMANCE CAPABILITIES	
Flow Pressure (PSI)	15-25
Wash Pump Motor Horsepower	3/4
Pump Capacity (GPM)	55
Minimum Chlorine Required (PPM)	50

WATER REQUIREMENTS		
	MINIMUM	RECOMMENDED
Inlet Temperature	120°F (49 °C)	140°F (60 °C)
Wash Operating Temperature	120°F (49 °C)	140°F (60 °C)
Rinse Operating Temperature	120°F (49 °C)	140°F (60 °C)

HOW TO SPECIFY: Conserv<sup>®</sup> XL

**Jackson WWS, Inc.**  
 Shipping Address: 6209 North U.S. Highway 25E, Gray, KY 40734  
 Mailing Address: P.O.Box 1060, Barbourville, KY 40906  
 Telephone: 888-800-5672 • Fax: 606-523-1799  
 Email: info@jacksonwws.com  
 07610-002-66-3 [02/14/14]

[www.jacksonwws.com](http://www.jacksonwws.com)

We reserve the right to change specifications in this bulletin without incurring any obligation for equipment previously or subsequently sold.