

---

## **SECTION 6: ELECTRICAL SCHEMATICS**

## SECTION 6: ELECTRICAL SCHEMATICS

### AJ-64CE (208-230 VOLT, 60 HZ, SINGLE PHASE) PRIMARY SIDE

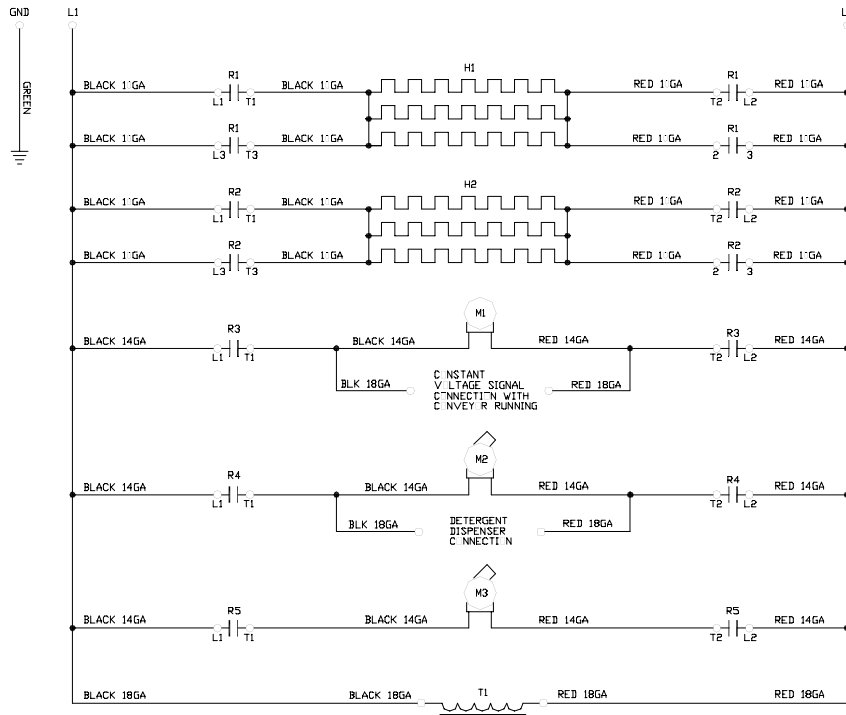

## SECTION 6: ELECTRICAL SCHEMATICS

### AJ-64CE (208-230 VOLT, 60 HZ, SINGLE PHASE) SECONDARY SIDE

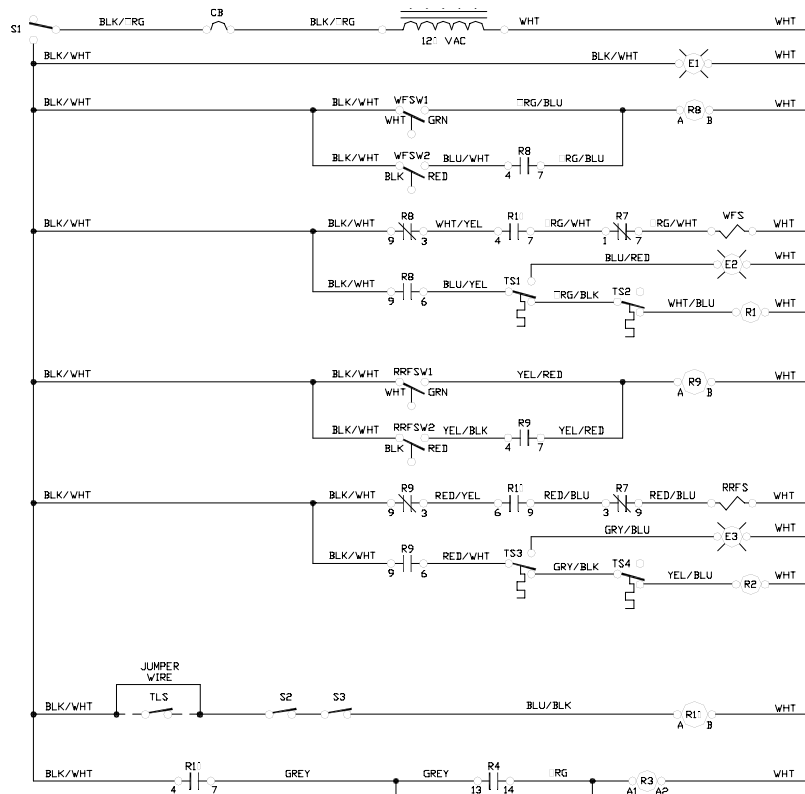

#### LEGEND

L1 L2 L3	P O W E R D I S T R I B U T I O N B L O C K
GND	G R O U N D
R1	W A S H T A N K H E A T C O N T A C T R
R2	R E C I R C U L A T I N G R I N S E H E A T C O N T A C T R
R3	D R I V E M O T O R C O N T A C T R
R4	W A S H P U M P M O T O R C O N T A C T R
R5	R E C I R C U L A T I N G R I N S E P U M P M O T O R C O N T A C T R
R6	F I N A L R I N S E R E L A Y # 1
R7	F I N A L R I N S E R E L A Y # 2
R8	W A S H T A N K F I L L R E L A Y
R9	R E C I R C U L A T I N G R I N S E T A N K F I L L R E L A Y
R1	D O O R S A F E T Y S W I T C H R E L A Y
H1	W A S H H E A T E R
H2	R E C I R C U L A T I N G R I N S E H E A T E R
M1	D R I V E M O T O R
M2	W A S H P U M P M O T O R
M3	R E C I R C U L A T I N G R I N S E P U M P M O T O R
CB	C E N T R A L C I R C U I T B R E A K E R
T1	C E N T R A L T R A N S F O R M E R
S1	P O W E R S W I T C H
S2	D O O R S A F E T Y S W I T C H 1
S3	D O O R S A F E T Y S W I T C H 2
S4	W A S H P U M P S W I T C H 1
S5	W A S H P U M P S W I T C H 2
S6	A U T O - M A N / D E L I M E S W I T C H
S7	R E C I R C U L A T I N G R I N S E P U M P S W I T C H
S8	F I N A L R I N S E S W I T C H
E1	P O W E R L I G H T
E2	W A S H H E A T E R H I G H L I M I T L I G H T
E3	R E C I R C U L A T I N G R I N S E H E A T E R H I G H L I M I T L I G H T
WFSW1	W A S H F L O A T S W I T C H 1
WFSW2	W A S H F L O A T S W I T C H 2
RRFSW1	R E C I R C U L A T I N G R I N S E F L O A T S W I T C H 1
RRFSW2	R E C I R C U L A T I N G R I N S E F L O A T S W I T C H 2
TS1	W A S H H E A T E R H I G H L I M I T T H E R M S T A T
TS2	W A S H R E G U L A T I N G T H E R M S T A T
TS3	R - R I N S E H E A T E R H I G H L I M I T T H E R M S T A T
TS4	R - R I N S E R E G U L A T I N G T H E R M S T A T
CWTS	C O L D W A T E R T H E R M S T A T ( P T I N A L )
CWV	C O L D W A T E R V A L V E ( P T I N A L )
TLS	T A B L E L I M I T S W I T C H ( P T I N A L )
WFS	W A S H F I L L S E N S I N G I D
RRFS	R E C I R C U L A T I N G R I N S E F I L L S E N S I N G I D
RS	F I N A L R I N S E S E N S I N G I D

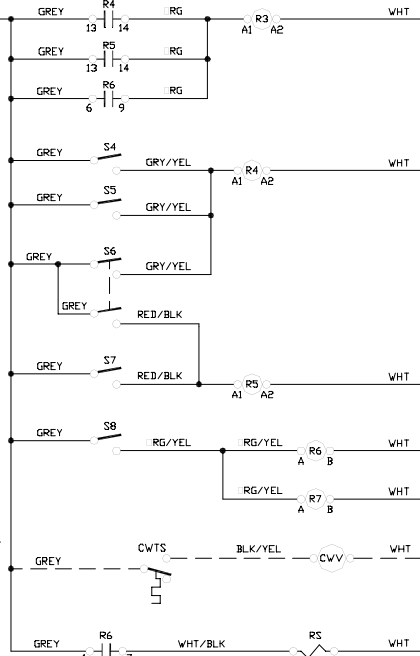

99 5-002-38-71

## SECTION 6: ELECTRICAL SCHEMATICS

### AJ-64CE (208-230 VOLT, 60 HZ, THREE PHASE) PRIMARY SIDE

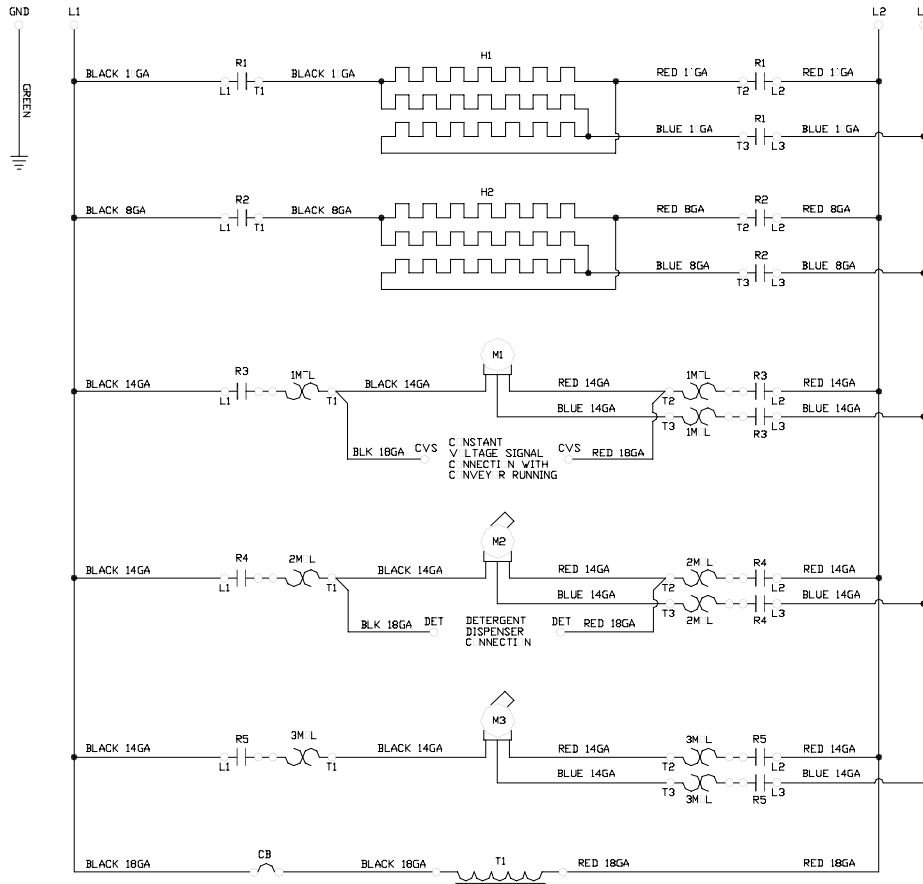

## SECTION 6: ELECTRICAL SCHEMATICS

### AJ-64CE (208-230 VOLT, 60 HZ, THREE PHASE) SECONDARY SIDE

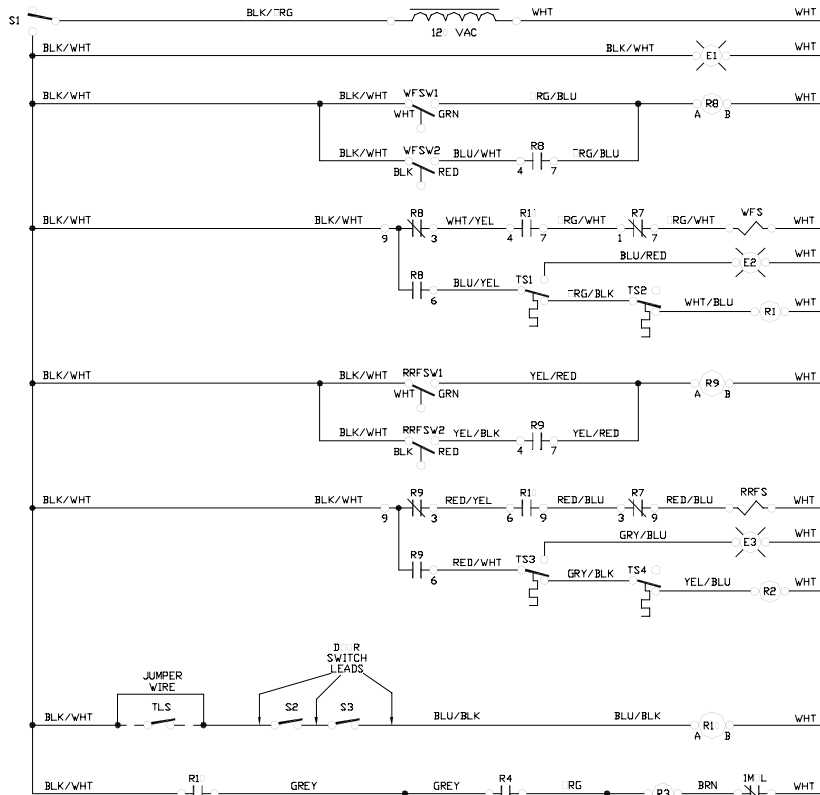

#### LEGEND

L1 L2 L3	P WER DISTRIBUTI N BL CK
GND	GR UND
R1	WASH TANK HEAT C N TACT R
R2	RECIRCULATING RINSE HEAT C N TACT R
R3	DRIVE M T R C N TACT R
R4	WASH PUMP M T R C N TACT R
R5	RECIRCULATING RINSE PUMP M T R C N TACT R
R6	FINAL RINSE RELAY #1
R7	FINAL RINSE RELAY #2
R8	WASH TANK FILL RELAY
R9	RECIRCULATING RINSE TANK FILL RELAY
R1	D I R SAFETY SWITCH RELAY
H1	WASH HEATER
H2	RECIRCULATING RINSE HEATER
M1	DRIVE M T R
M2	WASH PUMP M T R
M3	RECIRCULATING RINSE PUMP M T R
1M L	DRIVE M T R O V ERL AD
2M L	WASH PUMP M T R O V ERL AD
3M L	RECIRCULATING RINSE PUMP M T R O V ERL AD
CB	C N T R L C I R C U I T B R E A K E R
T1	C N T R L T R A N S F R M E R
DET	D E T E R G E N T D I S P E N S E R C N N E C T I N
CVS	C N S T A N T V L T A G E S I G N A L
S1	P W E R S W I T C H
S2	D I R S A F E T Y S W I T C H 1
S3	D I R S A F E T Y S W I T C H 2
S4	W A S H P U M P S W I T C H 1
S5	W A S H P U M P S W I T C H 2
S6	A U T - M A N / D E L I M E S W I T C H
S7	RECIRCULATING RINSE PUMP SWITCH
S8	FINAL RINSE SWITCH
E1	P W E R L I G H T
E2	W A S H H E A T E R H I G H L I M I T L I G H T
E3	RECIRCULATING RINSE HEATER HIGH LIMIT LIGHT
WFSW1	W A S H F L A T S W I T C H 1
WFSW2	W A S H F L A T S W I T C H 2
RRFSW1	RECIRCULATING RINSE FL AT SWITCH 1
RRFSW2	RECIRCULATING RINSE FL AT SWITCH 2
TS1	W A S H H E A T E R H I G H L I M I T T H E R M S T A T
TS2	W A S H R E G U L A T I N G T H E R M S T A T
TS3	R - R I N S E H E A T E R H I G H L I M I T T H E R M S T A T
TS4	R - R I N S E R E G U L A T I N G T H E R M S T A T
CWTS	C L D W A T E R T H E R M S T A T ( P T I N A L)
CWV	C L D W A T E R V A L V E ( P T I N A L)
TL	T A B L E L I M I T S W I T C H ( P T I N A L)
WFS	W A S H F I L L S L E N I D
RRFS	RECIRCULATING RINSE FILL S L E N I D
RS	F I N A L R I N S E S L E N I D

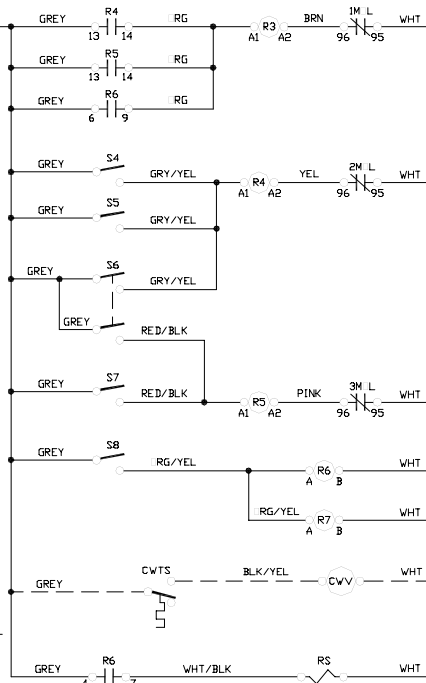

99 5-31-82-66

## SECTION 6: ELECTRICAL SCHEMATICS

### AJ-64CE (460 VOLT, 60 HZ, THREE PHASE) PRIMARY SIDE

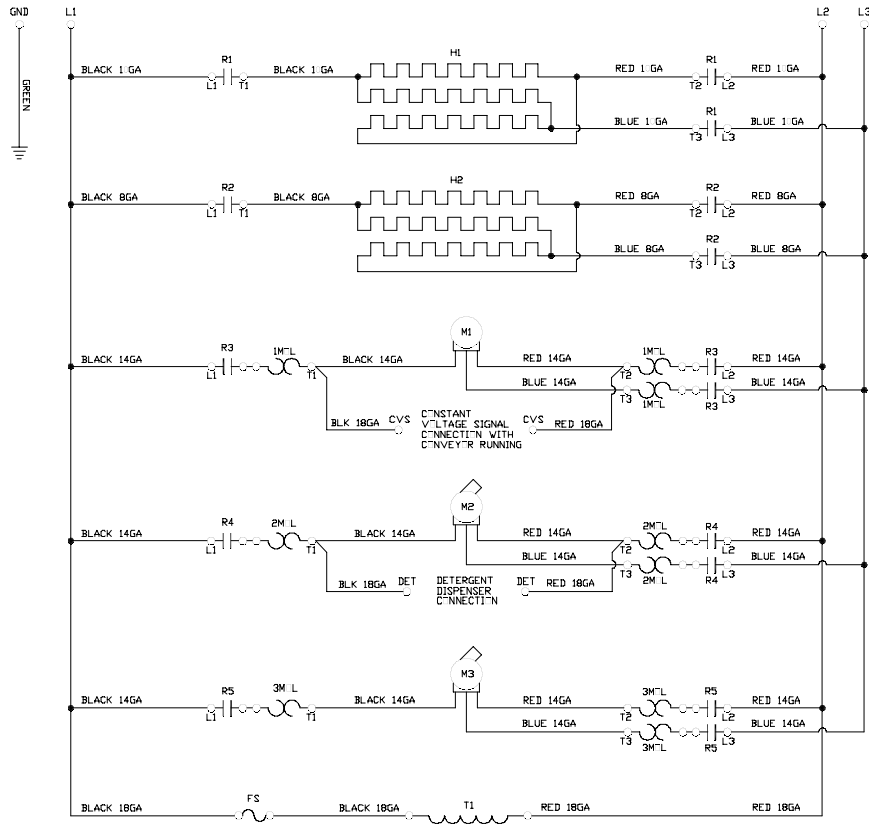

## SECTION 6: ELECTRICAL SCHEMATICS

### AJ-64CE (460 VOLT, 60 HZ, THREE PHASE) SECONDARY SIDE

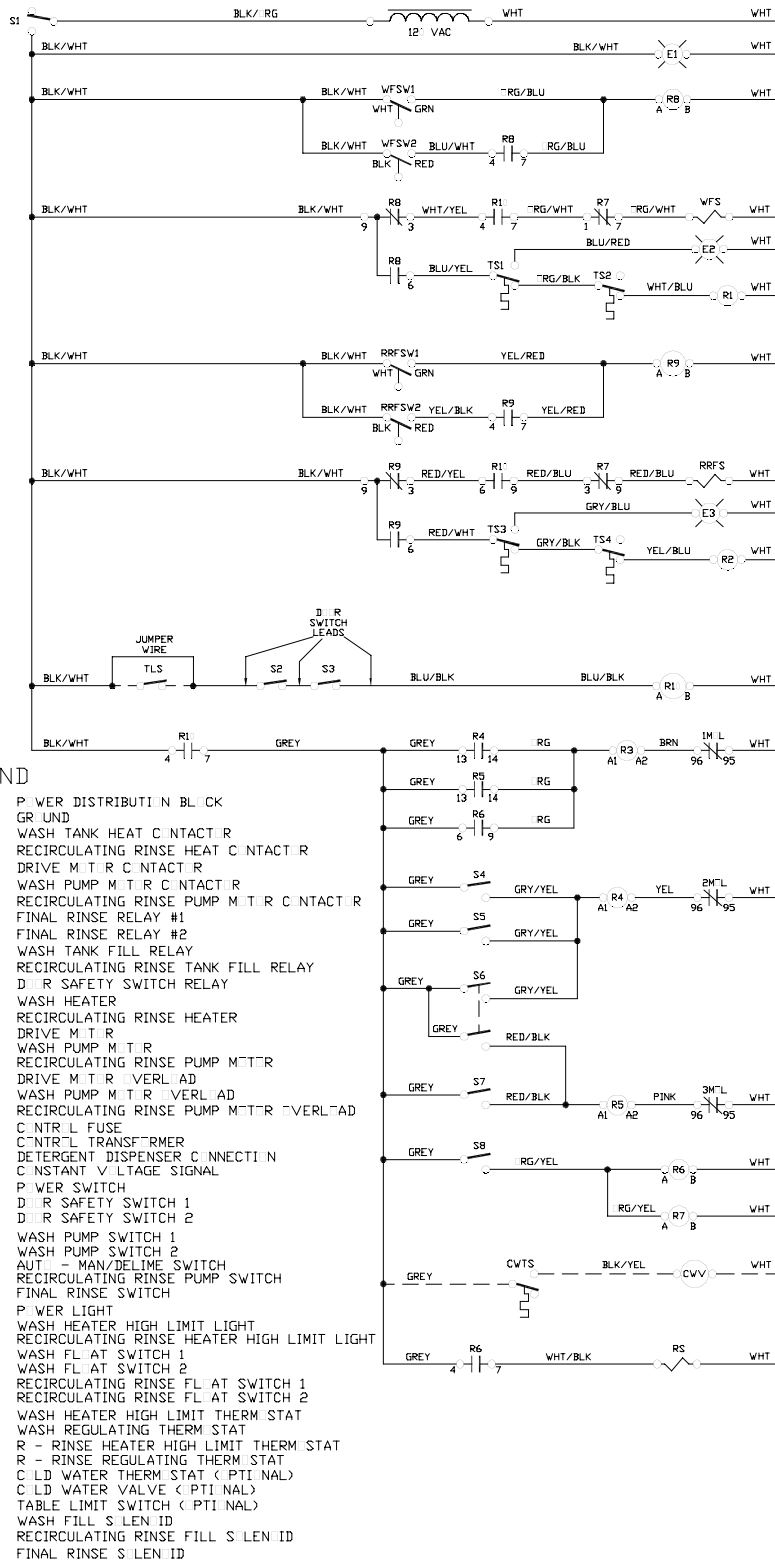

09905-031-95-56

## SECTION 6: ELECTRICAL SCHEMATICS

### AJ-64CS (208-230 VOLT, 60 HZ, SINGLE PHASE) PRIMARY SIDE

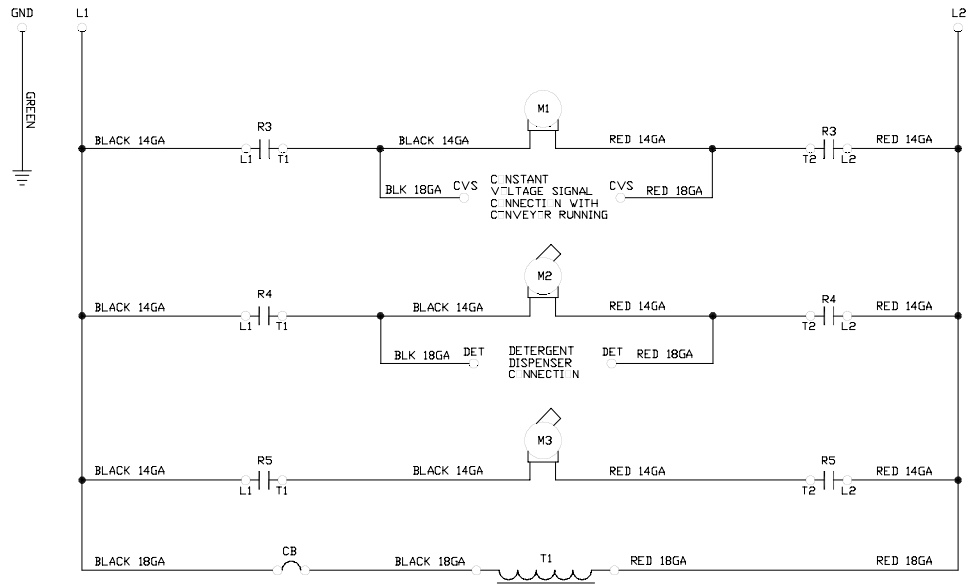



## SECTION 6: ELECTRICAL SCHEMATICS

### AJ-64CS (208-230 VOLT, 60 HZ, SINGLE PHASE) SECONDARY SIDE

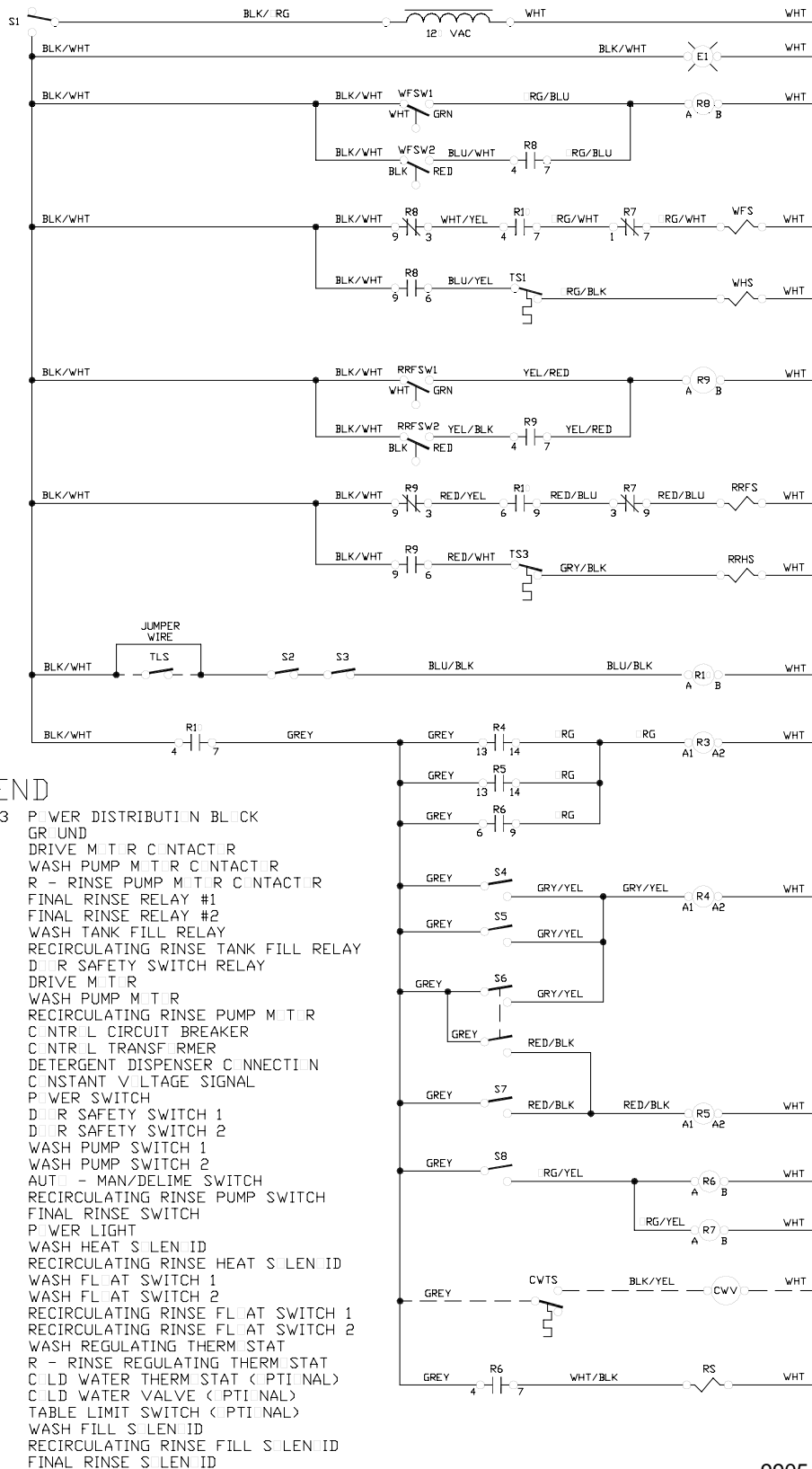

9905-002-55-96a

## SECTION 6: ELECTRICAL SCHEMATICS

### AJ-64CS (208-230 VOLT, 60 HZ, THREE PHASE) PRIMARY SIDE

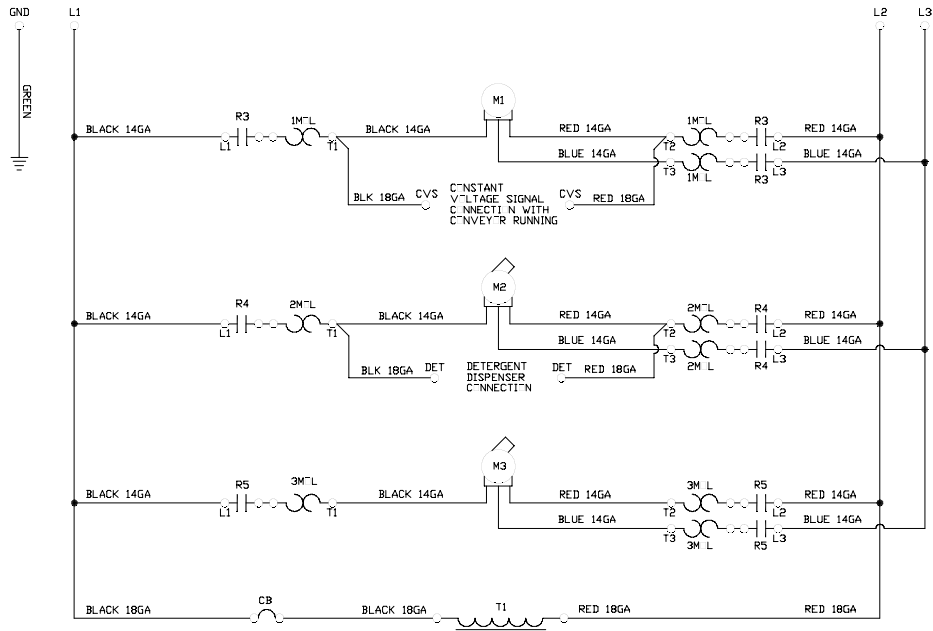

# SECTION 6: ELECTRICAL SCHEMATICS

## AJ-64CS (208-230 VOLT, 60 HZ, THREE PHASE) SECONDARY SIDE

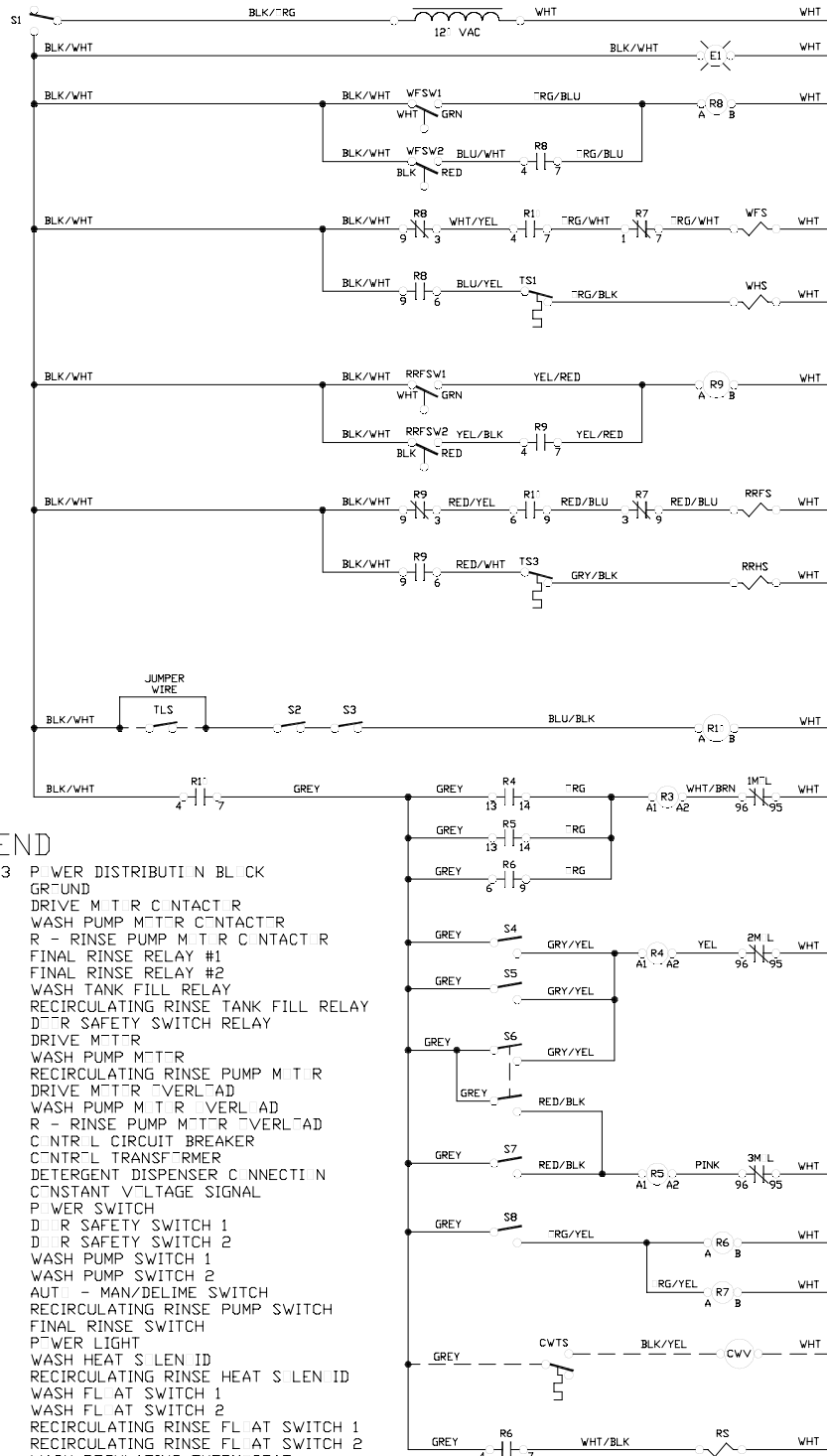

### LEGEND

L1 L2 L3	POWER DISTRIBUTION BLOCK
GND	GROUND
R3	DRIVE MOTOR CONTACTOR
R4	WASH PUMP MOTOR CONTACTOR
R5	R - RINSE PUMP MOTOR CONTACTOR
R6	FINAL RINSE RELAY #1
R7	FINAL RINSE RELAY #2
R8	WASH TANK FILL RELAY
R9	RECIRCULATING RINSE TANK FILL RELAY
R10	DRIVE SAFETY SWITCH RELAY
M1	DRIVE MOTOR
M2	WASH PUMP MOTOR
M3	RECIRCULATING RINSE PUMP MOTOR
1M <sup>L</sup>	DRIVE MOTOR OVERLOAD
2M <sup>L</sup>	WASH PUMP MOTOR OVERLOAD
3M <sup>L</sup>	R - RINSE PUMP MOTOR OVERLOAD
CB	CONTROL CIRCUIT BREAKER
T1	CONTROL TRANSFORMER
DET	DETERGENT DISPENSER CONNECTION
CVS	CONSTANT VOLTAGE SIGNAL
S1	POWER SWITCH
S2	DRIVE SAFETY SWITCH 1
S3	DRIVE SAFETY SWITCH 2
S4	WASH PUMP SWITCH 1
S5	WASH PUMP SWITCH 2
S6	AUTO - MAN/DELIME SWITCH
S7	RECIRCULATING RINSE PUMP SWITCH
S8	FINAL RINSE SWITCH
E1	POWER LIGHT
WHS	WASH HEAT SLENID
RRHS	RECIRCULATING RINSE HEAT SLENID
WFSW1	WASH FILL SWITCH 1
WFSW2	WASH FILL SWITCH 2
RRFSW1	RECIRCULATING RINSE FILL SWITCH 1
RRFSW2	RECIRCULATING RINSE FILL SWITCH 2
TS1	WASH REGULATING THERMISTAT
TS3	R - RINSE REGULATING THERMISTAT
CWTS	COLD WATER THERMISTAT (OPTIONAL)
CWV	COLD WATER VALVE (OPTIONAL)
TLS	TABLE LIMIT SWITCH (OPTIONAL)
WFS	WASH FILL SLENID
RRFS	RECIRCULATING RINSE FILL SLENID
RS	FINAL RINSE SLENID

99 5-12-17-6

## SECTION 6: ELECTRICAL SCHEMATICS

### AJ-64CS (460 VOLT, 60 HZ, THREE PHASE) PRIMARY SIDE

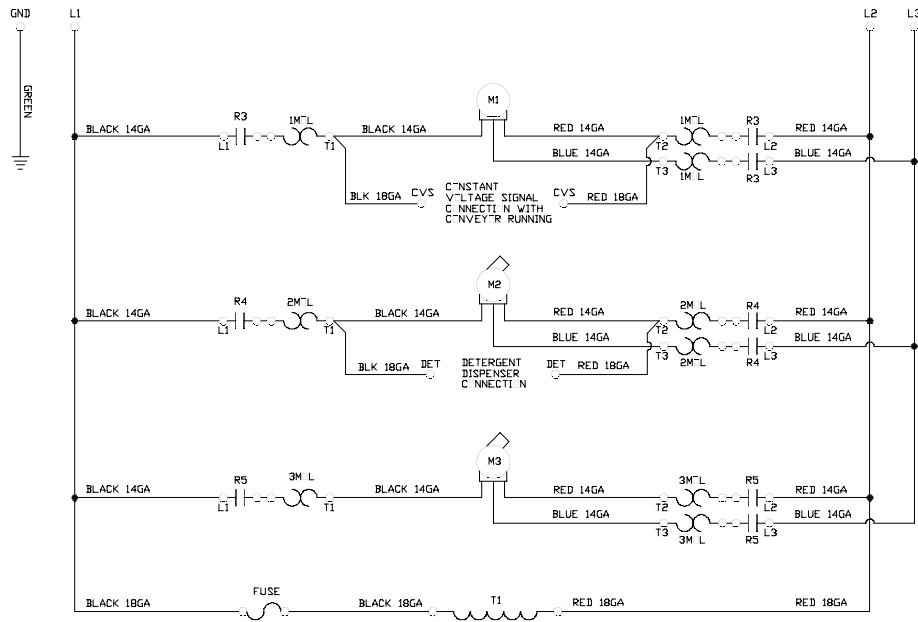

## SECTION 6: ELECTRICAL SCHEMATICS

### AJ-64CS (460 VOLT, 60 HZ, THREE PHASE) SECONDARY SIDE

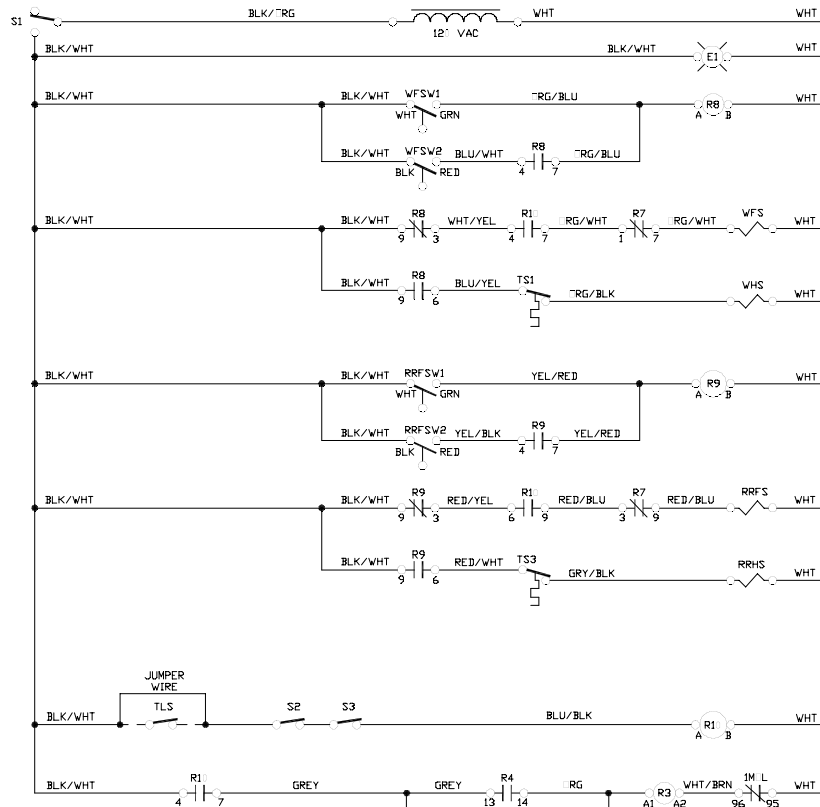

#### LEGEND

L1 L2 L3	POWER DISTRIBUTION BLACK
GND	GROUND
R3	DRIVE MOTOR CONTACTOR
R4	WASH PUMP MOTOR CONTACTOR
R5	R - RINSE PUMP MOTOR CONTACTOR
R6	FINAL RINSE RELAY #1
R7	FINAL RINSE RELAY #2
R8	WASH TANK FILL RELAY
R9	RECIRCULATING RINSE TANK FILL RELAY
R10	DOOR SAFETY SWITCH RELAY
M1	DRIVE MOTOR
M2	WASH PUMP MOTOR
M3	RECIRCULATING RINSE PUMP MOTOR
1M L	DRIVE MOTOR OVERLOAD
2M L	WASH PUMP MOTOR OVERLOAD
3M L	R - RINSE PUMP MOTOR OVERLOAD
FUSE	CENTRAL FUSE
T1	CENTRAL TRANSFORMER
DET	DETERGENT DISPENSER CONNECTION
CVS	CONSTANT VOLTAGE SIGNAL
S1	POWER SWITCH
S2	DOOR SAFETY SWITCH 1
S3	DOOR SAFETY SWITCH 2
S4	WASH PUMP SWITCH 1
S5	WASH PUMP SWITCH 2
S6	AUT - MAN/DELIME SWITCH
S7	RECIRCULATING RINSE PUMP SWITCH
S8	FINAL RINSE SWITCH
E1	POWER LIGHT
WHS	WASH HEAT SOLENOID
RRHS	RECIRCULATING RINSE HEAT SOLENOID
WFSW1	WASH FILL SWITCH 1
WFSW2	WASH FILL SWITCH 2
RRFSW1	RECIRCULATING RINSE FILL SWITCH 1
RRFSW2	RECIRCULATING RINSE FILL SWITCH 2
TS1	WASH REGULATING THERM STAT
TS3	R - RINSE REGULATING THERM STAT
CWTS	COLD WATER THERM STAT (PTIONAL)
CWV	COLD WATER VALVE (PTIONAL)
TLS	TABLE LIMIT SWITCH (PTIONAL)
WFS	WASH FILL SOLENOID
RRFS	RECIRCULATING RINSE FILL SOLENOID
RS	FINAL RINSE SOLENOID

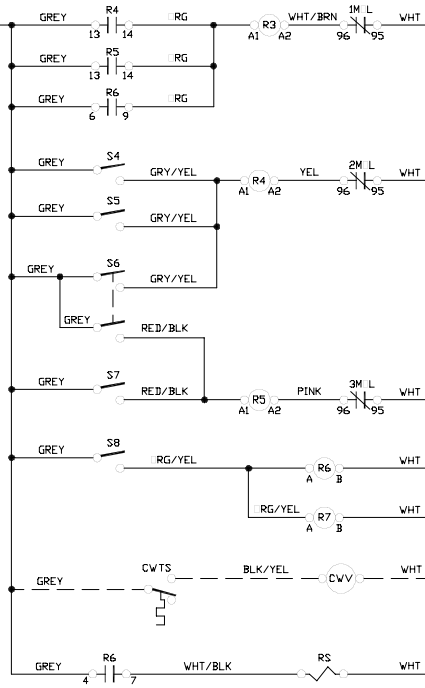

99-5-002-55-97A

## SECTION 6: ELECTRICAL SCHEMATICS

### AJ-86CE & AJ-100CE (208-230 VOLT, 60 HZ, SINGLE PHASE) PRIMARY SIDE

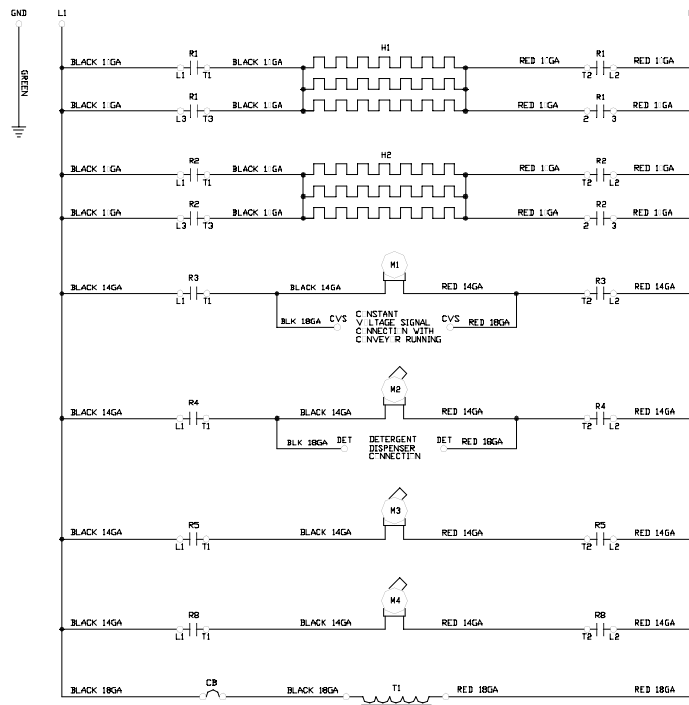

# SECTION 6: ELECTRICAL SCHEMATICS

## AJ-86CE & AJ-100CE (208-230 VOLT, 60 HZ, SINGLE PHASE) SECONDARY SIDE

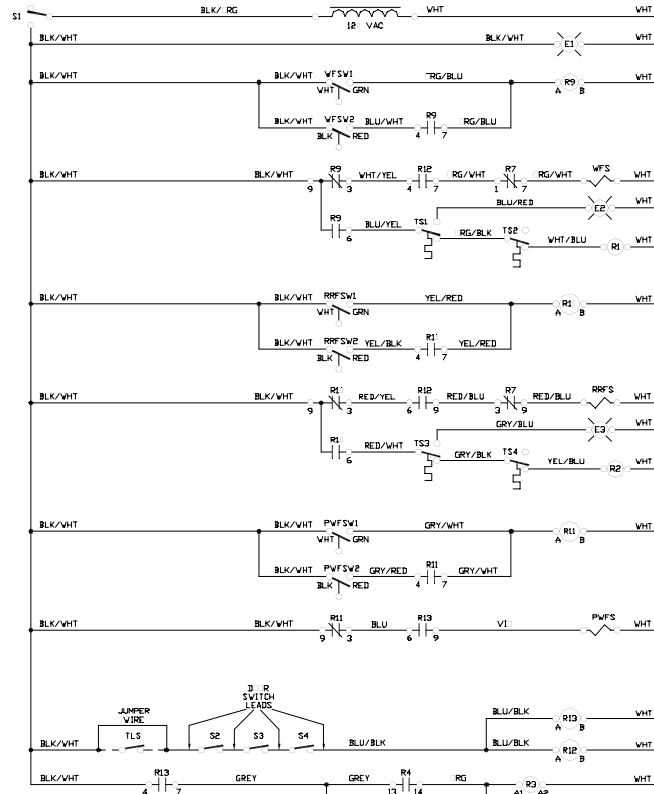

### LEGEND

- L1 L2 L3 POWER DISTRIBUTION BLOCK
- GR UND GROUND
- R1 WASH TANK HEAT CONTACTOR
- R2 RECIRCULATING RINSE HEAT CONTACTOR
- R3 DRIVE MOTOR CONTACTOR
- R4 WASH PUMP MOTOR CONTACTOR
- R5 RECIRCULATING RINSE PUMP MOTOR CONTACTOR
- R6 FINAL RINSE RELAY #1
- R7 FINAL RINSE RELAY #2
- R8 PREWASH PUMP MOTOR CONTACTOR
- R9 WASH TANK FILL RELAY
- R10 RECIRCULATING RINSE TANK FILL RELAY
- R11 PRE-WASH TANK FILL RELAY
- R12 DTR SAFETY SWITCH RELAY #1
- R13 DTR SAFETY SWITCH RELAY #2
- H1 WASH HEATER
- H2 RECIRCULATING RINSE HEATER
- M1 DRIVE MOTOR
- M2 WASH PUMP MOTOR
- M3 RECIRCULATING RINSE PUMP MOTOR
- M4 PRE-WASH PUMP MOTOR
- CB CONTROL CIRCUIT BREAKER
- CNL CONTROL TRANSFORMER
- DET DETERGENT DISPENSER CONNECTION
- CVS CONSTANT VOLTAGE SIGNAL
- S1 POWER SWITCH
- S2 DTR SAFETY SWITCH 1
- S3 DTR SAFETY SWITCH 2
- S4 DTR SAFETY SWITCH 3
- S5 WASH PUMP SWITCH 1
- S6 WASH PUMP SWITCH 2
- S7 AUT - MAN/DELIME SWITCH
- S8 RECIRCULATING RINSE PUMP SWITCH
- S9 FINAL RINSE SWITCH
- S10 PRE-WASH PUMP SWITCH
- E1 POWER LIGHT
- E2 WASH HEATER HIGH LIMIT LIGHT
- E3 RECIRCULATING RINSE HEATER HIGH LIMIT LIGHT
- WFSV1 WASH FLAT SWITCH 1
- WFSV2 WASH FLAT SWITCH 2
- RRF5W1 RECIRCULATING RINSE FLAT SWITCH 1
- RRF5W2 RECIRCULATING RINSE FLAT SWITCH 2
- PWF5W1 PRE-WASH FLAT SWITCH 1
- PWF5W2 PRE-WASH FLAT SWITCH 2
- TS1 HEATER HIGH LIMIT THERM STAT
- TS2 WASH REGULATING THERM STAT
- TS3 R - RINSE HEATER HIGH LIMIT THERM STAT
- TS4 R - RINSE REGULATING THERM STAT
- CVTS CLD WATER THERM STAT (PTI NAL)
- CVV CLD WATER VALVE (PTI NAL)
- TLS TABLE LIMIT SWITCH (PTI NAL)
- WFS WASH FILL SLEN ID
- RRFS RECIRCULATING RINSE FILL SLEN ID
- PWFS PRE-WASH FILL SLEN ID
- RS FINAL RINSE SLEN ID

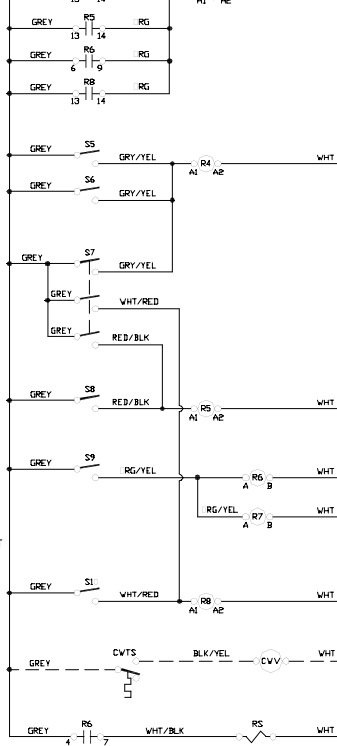

09905-031-80-35

## SECTION 6: ELECTRICAL SCHEMATICS

### AJ-86CE & AJ-100CE (208-230 VOLT, 60 HZ, THREE PHASE) PRIMARY SIDE

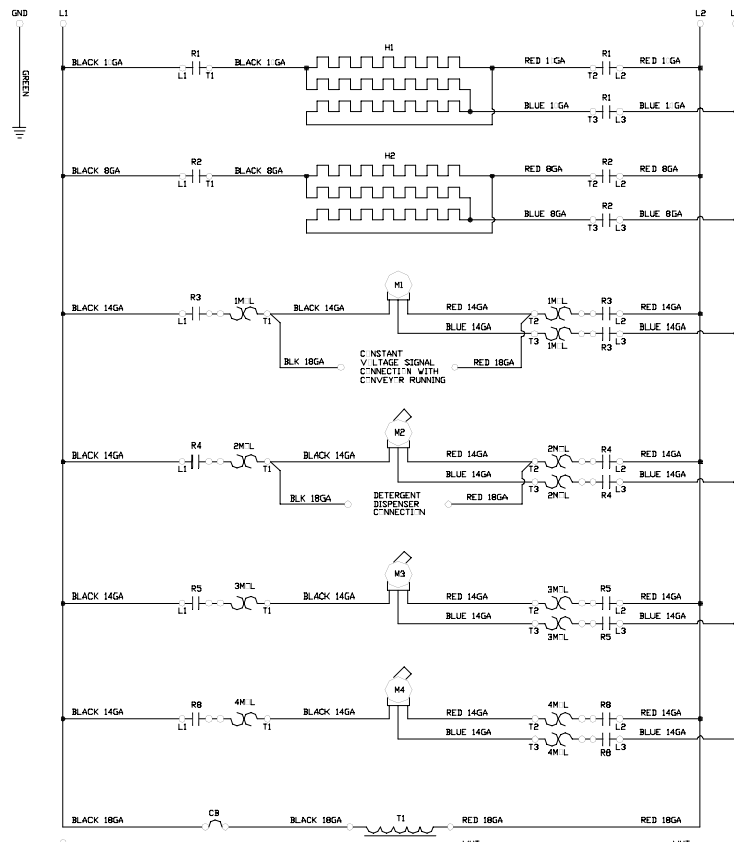



# SECTION 6: ELECTRICAL SCHEMATICS

## AJ-86CE & AJ-100CE (208-230 VOLT, 60 HZ, THREE PHASE) SECONDARY SIDE

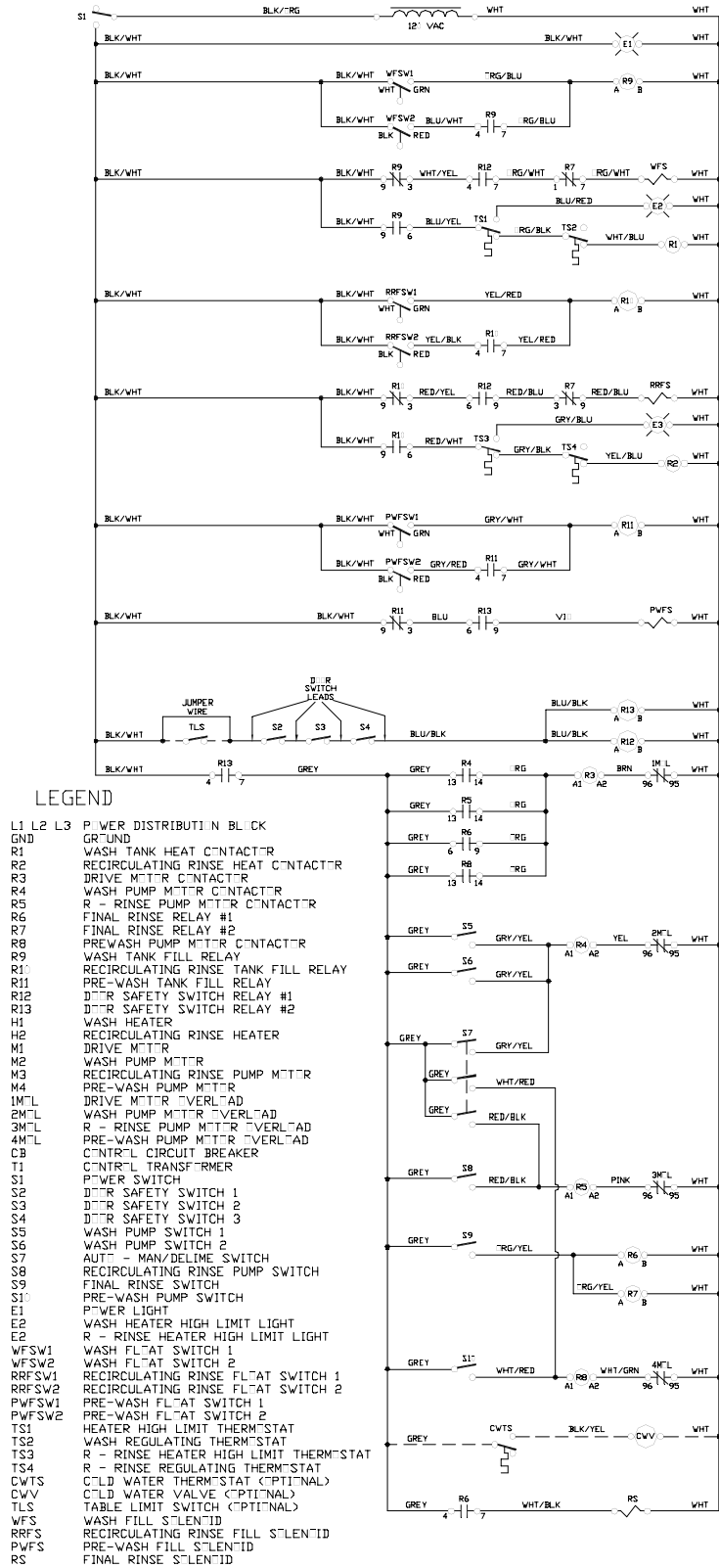

## SECTION 6: ELECTRICAL SCHEMATICS

### AJ-86CE & AJ-100CE (460 VOLT, 60 HZ, THREE PHASE) PRIMARY SIDE

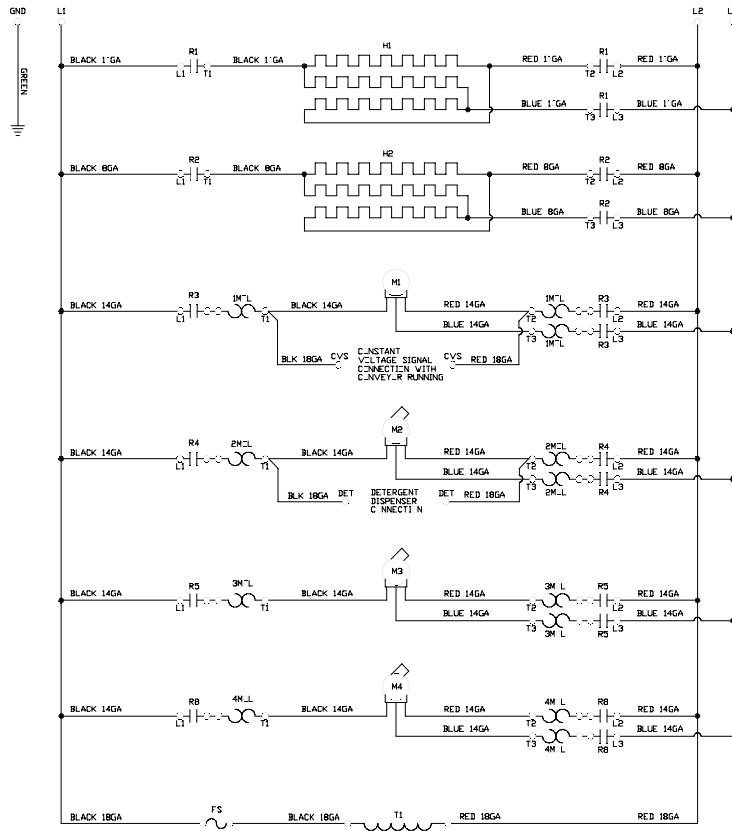

# SECTION 6: ELECTRICAL SCHEMATICS

## AJ-86CE & AJ-100CE (460 VOLT, 60 HZ, THREE PHASE) SECONDARY SIDE

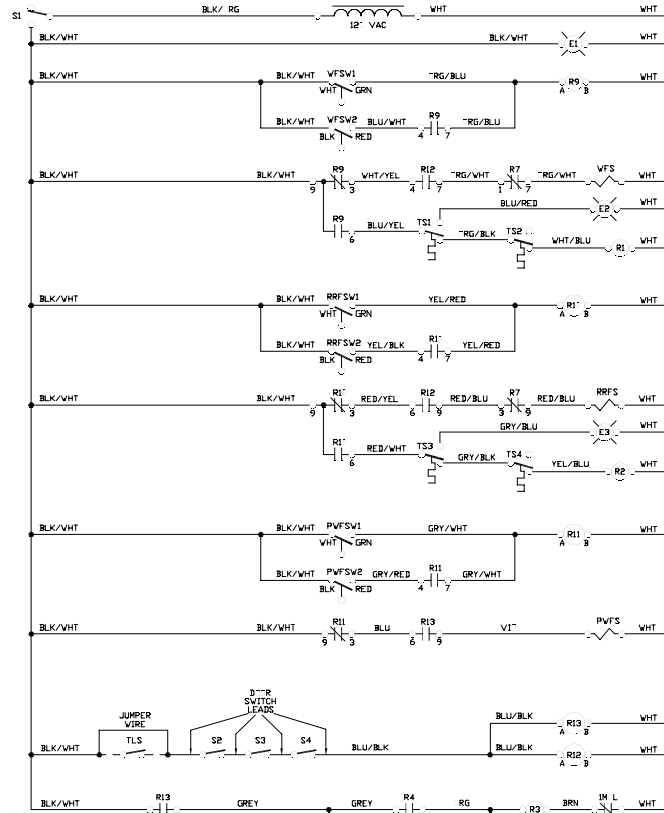

### LEGEND

- L1 L2 L3 P-TWER DISTRIBUTION BLK CK
- GND GR-UND
- R1 WASH TANK HEAT C N TACT R
- R2 RECIRCULATING RINSE HEAT C N TACT R
- R3 DRIVE M T T R C N TACT R
- R4 WASH PUMP M T R C N TACT R
- R5 RECIRCULATING RINSE PUMP M T R C N TACT R
- R6 FINAL RINSE RELAY #1
- R7 FINAL RINSE RELAY #2
- R8 PREWASH PUMP M T R C N TACT R
- R9 WASH TANK FILL RELAY
- R10 RECIRCULATING RINSE TANK FILL RELAY
- R11 PRE-WASH TANK FILL RELAY
- R12 D R SAFETY SWITCH RELAY #1
- R13 D T R SAFETY SWITCH RELAY #2
- H1 WASH HEATER
- H2 RECIRCULATING RINSE HEATER
- M1 DRIVE M T T R
- M2 WASH PUMP M T R
- M3 RECIRCULATING RINSE PUMP M T R
- M4 PRE-WASH PUMP M T R
- 1M L DRIVE M T T R V E R L A D
- 2M L WASH PUMP M T T R V E R L A D
- 3M L RECIRCULATING RINSE PUMP M T T R V E R L A D
- 4M L PRE-WASH PUMP M T T R V E R L A D
- FS C N T R L FUSE
- T1 C N T R L T R A N S F R M E R
- DET D E T E R G E N T D I S P E N S E R C N N E C T I N
- CVS C N S T A N T V L T A G E S I G N A L
- P P W E R S W I T C H
- S1 D R SAFETY SWITCH 1
- S2 D R SAFETY SWITCH 2
- S3 D R SAFETY SWITCH 3
- S4 WASH PUMP SWITCH 1
- S5 WASH PUMP SWITCH 2
- S6 A U T - M A N / D E L I M E S W I T C H
- S7 R E C I R C U L A T I N G R I N S E P U M P S W I T C H
- S8 F I N A L R I N S E S W I T C H
- S9 P R E - W A S H P U M P S W I T C H
- S1 P W E R L I G H T
- E1 W A S H H E A T E R H I G H L I M I T L I G H T
- E2 W A S H F L A T S W I T C H 1
- WFSW1 W A S H F L A T S W I T C H 2
- WFSW2 R E C I R C U L A T I N G R I N S E F L A T S W I T C H 1
- RRFSW1 R E C I R C U L A T I N G R I N S E F L A T S W I T C H 2
- RRFSW2 P R E - W A S H F L A T S W I T C H 1
- PWFSW1 P R E - W A S H F L A T S W I T C H 2
- PWFSW2 H E A T E R H I G H L I M I T T H E R M S T A T
- TS1 W A S H R E G U L A T I N G T H E R M S T A T
- TS2 R - R I N S E H E A T E R H I G H L I M I T T H E R M S T A T
- TS3 R - R I N S E R E G U L A T I N G T H E R M S T A T
- TS4 C L D W A T E R T H E R M S T A T ( P T I N A L )
- CVTS C L D W A T E R V A L V E ( P T I N A L )
- CVV T A B L E L I M I T S W I T C H ( P T I N A L )
- TLS T A B L E L I M I T S W I T C H ( P T I N A L )
- WFS W A S H F I L L S L E N I D
- RRFS R E C I R C U L A T I N G R I N S E F I L L S L E N I D
- PWFS P R E - W A S H F I L L S L E N I D
- RS F I N A L R I N S E S L E N I D

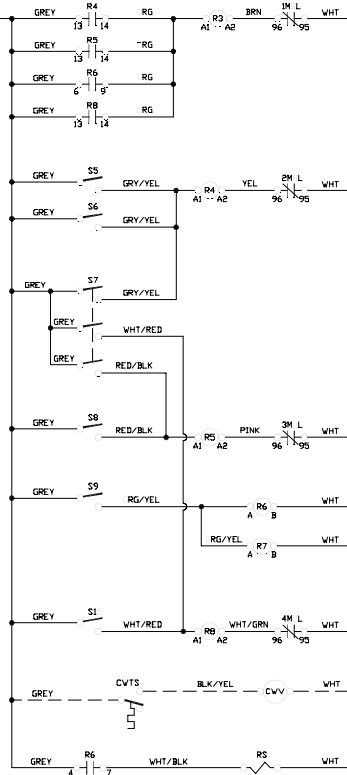

99 5- 41-94-99

## SECTION 6: ELECTRICAL SCHEMATICS

### AJ-86CS & AJ-100CS (208-230 VOLT, 60 HZ, SINGLE PHASE) PRIMARY SIDE

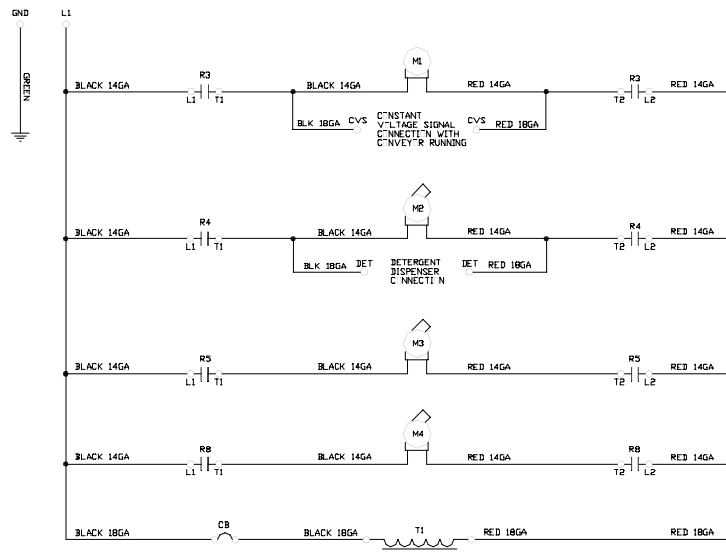

## SECTION 6: ELECTRICAL SCHEMATICS

### AJ-86CS & AJ-100CS (208-230 VOLT, 60 HZ, SINGLE PHASE) SECONDARY SIDE

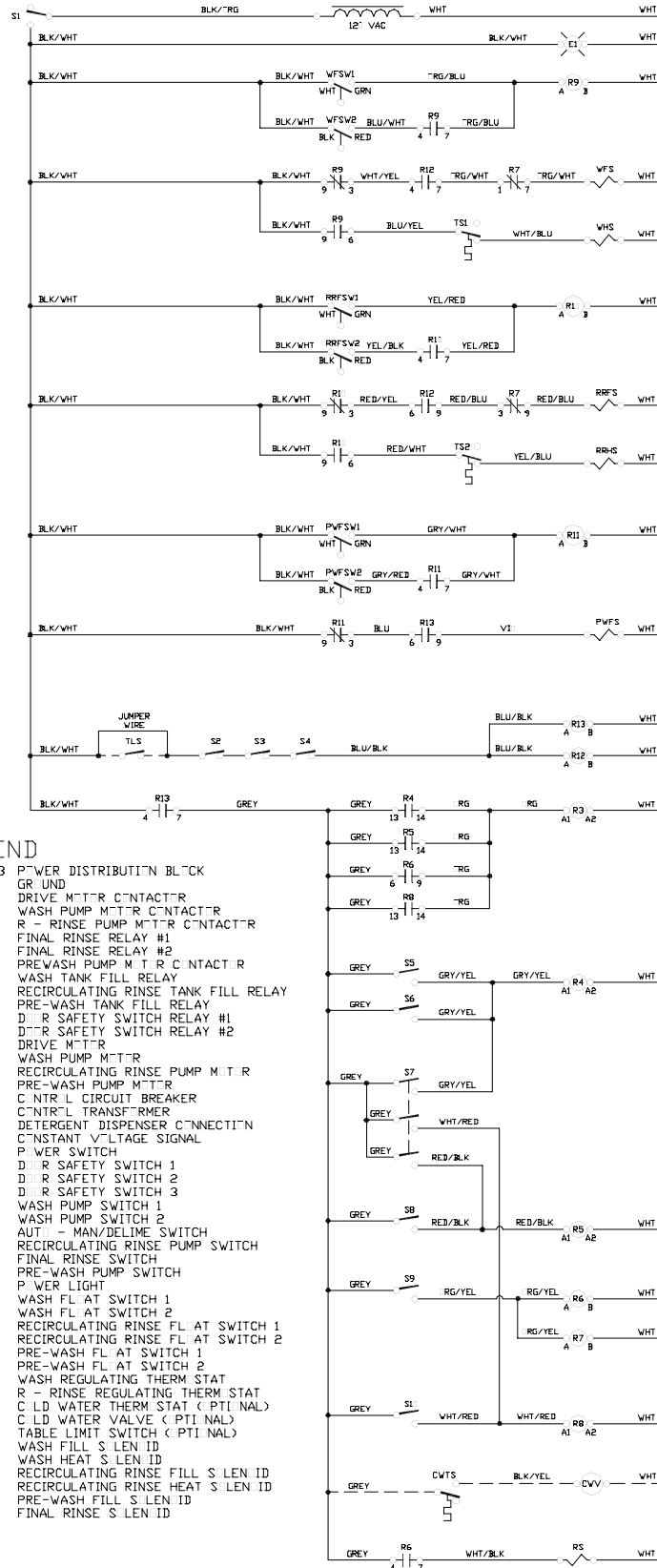

99-5-002-56-3

## SECTION 6: ELECTRICAL SCHEMATICS

### AJ-86CS & AJ-100CS (208-230 VOLT, 60 HZ, THREE PHASE) PRIMARY SIDE

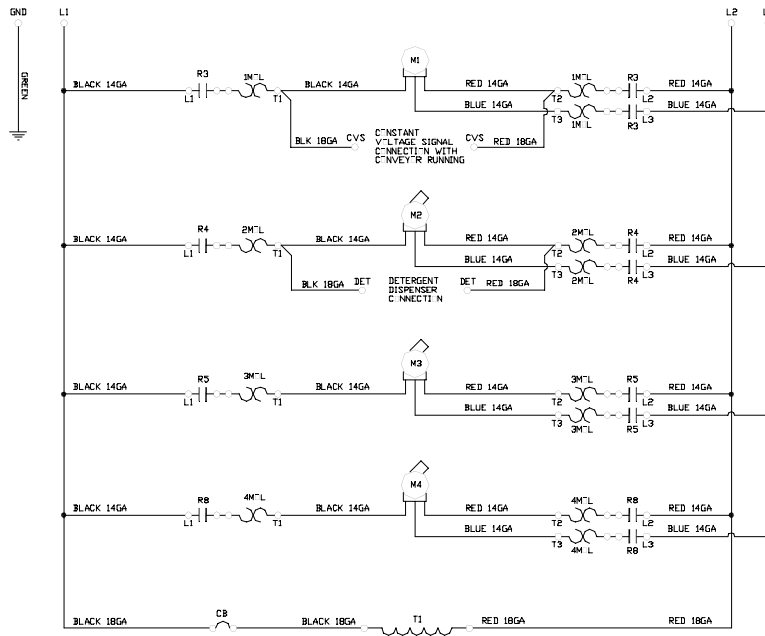

# SECTION 6: ELECTRICAL SCHEMATICS

## AJ-86CS & AJ-100CS (208-230 VOLT, 60 HZ, THREE PHASE) SECONDARY SIDE

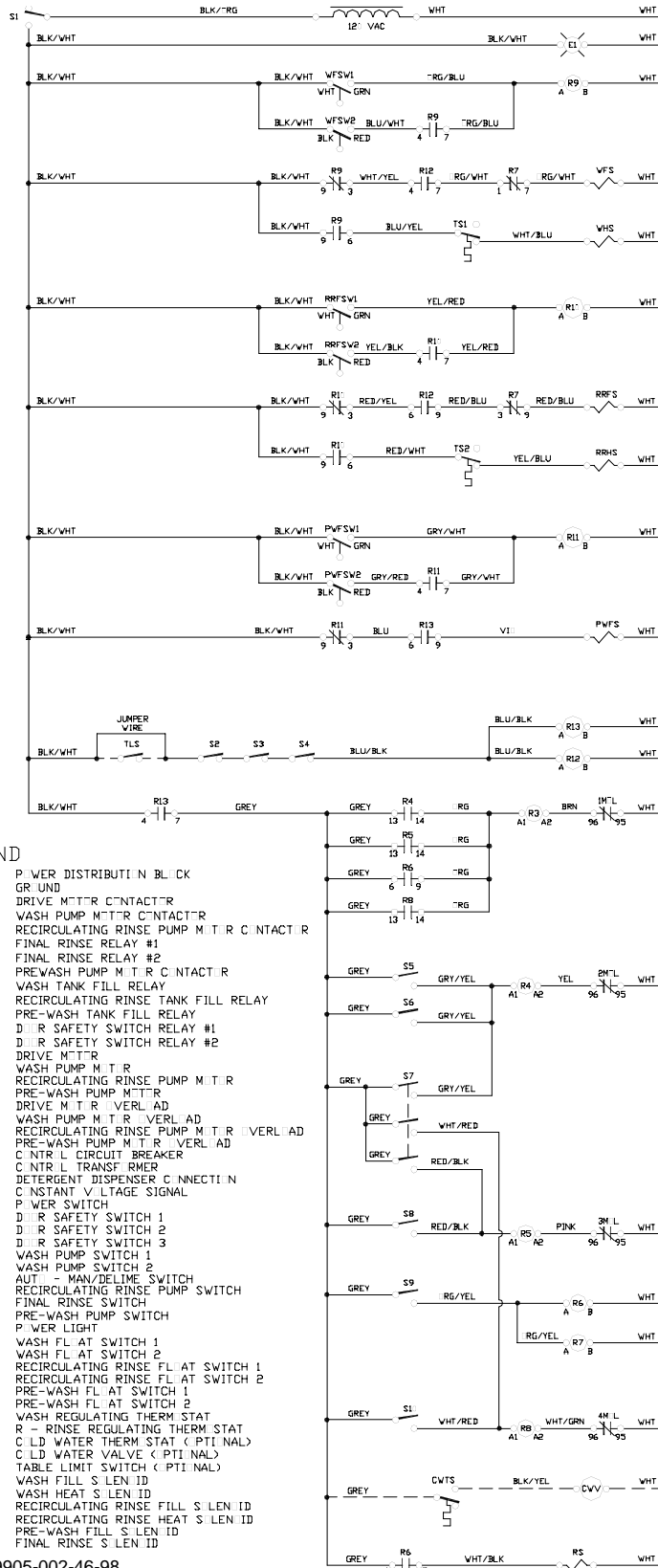

### LEGEND

- L1 L2 L3 POWER DISTRIBUTION BLOCK
- GND GROUND
- R3 DRIVE MOTOR CONTACTOR
- R4 WASH PUMP MOTOR CONTACTOR
- R5 RECIRCULATING RINSE PUMP MOTOR CONTACTOR
- R6 FINAL RINSE RELAY #1
- R7 FINAL RINSE RELAY #2
- R8 PRE-WASH PUMP MOTOR CONTACTOR
- R9 WASH TANK FILL RELAY
- R10 RECIRCULATING RINSE TANK FILL RELAY
- R11 PRE-WASH TANK FILL RELAY
- R12 D.R. SAFETY SWITCH RELAY #1
- R13 D.R. SAFETY SWITCH RELAY #2
- M1 DRIVE MOTOR
- M2 WASH PUMP MOTOR
- M3 RECIRCULATING RINSE PUMP MOTOR
- M4 PRE-WASH PUMP MOTOR
- 1M L DRIVE MOTOR OVERLOAD
- 2M L WASH PUMP MOTOR OVERLOAD
- 3M L RECIRCULATING RINSE PUMP MOTOR OVERLOAD
- 4M L PRE-WASH PUMP MOTOR OVERLOAD
- CB CENTER LINE CIRCUIT BREAKER
- TI THERMAL INTERRUPTER
- DET DETERGENT DISPENSER CONNECTION
- CVS CONSTANT VOLTAGE SIGNAL
- S1 POWER SWITCH
- S2 D.R. SAFETY SWITCH 1
- S3 D.R. SAFETY SWITCH 2
- S4 D.R. SAFETY SWITCH 3
- S5 WASH PUMP SWITCH 1
- S6 WASH PUMP SWITCH 2
- S7 AUTO-MAN/DELIMIT SWITCH
- S8 RECIRCULATING RINSE PUMP SWITCH
- S9 FINAL RINSE SWITCH
- S1 PRE-WASH PUMP SWITCH
- E1 POWER LIGHT
- WFSV1 WASH FILL AT SWITCH 1
- WFSV2 WASH FILL AT SWITCH 2
- RRFSV1 RECIRCULATING RINSE FILL AT SWITCH 1
- RRFSV2 RECIRCULATING RINSE FILL AT SWITCH 2
- PVFSV1 PRE-WASH FILL AT SWITCH 1
- PVFSV2 PRE-WASH FILL AT SWITCH 2
- TS1 WASH REGULATING THERMISTAT
- TS2 RINSE REGULATING THERMISTAT
- CWTs C.L.D. WATER THERMISTAT (PTI NAL)
- CVV C.L.D. WATER VALVE (PTI NAL)
- TLS TABLE LIMIT SWITCH (PTI NAL)
- WFS WASH FILL SLENOID
- WHS WASH HEAT SLENOID
- RRFS RECIRCULATING RINSE FILL SLENOID
- RRHS RECIRCULATING RINSE HEAT SLENOID
- PVFS PRE-WASH FILL SLENOID
- RS FINAL RINSE SLENOID

09905-002-46-98

## SECTION 6: ELECTRICAL SCHEMATICS

### AJ-86CS & AJ-100CS (460 VOLT, 60 HZ, THREE PHASE) PRIMARY SIDE

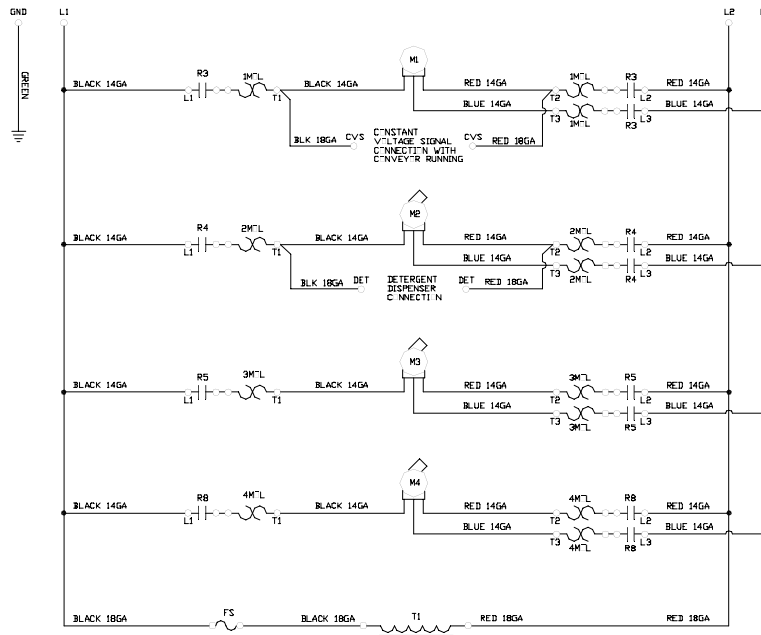



# SECTION 6: ELECTRICAL SCHEMATICS

## AJ-86CS & AJ-100CS (460 VOLT, 60 HZ, THREE PHASE) SECONDARY SIDE

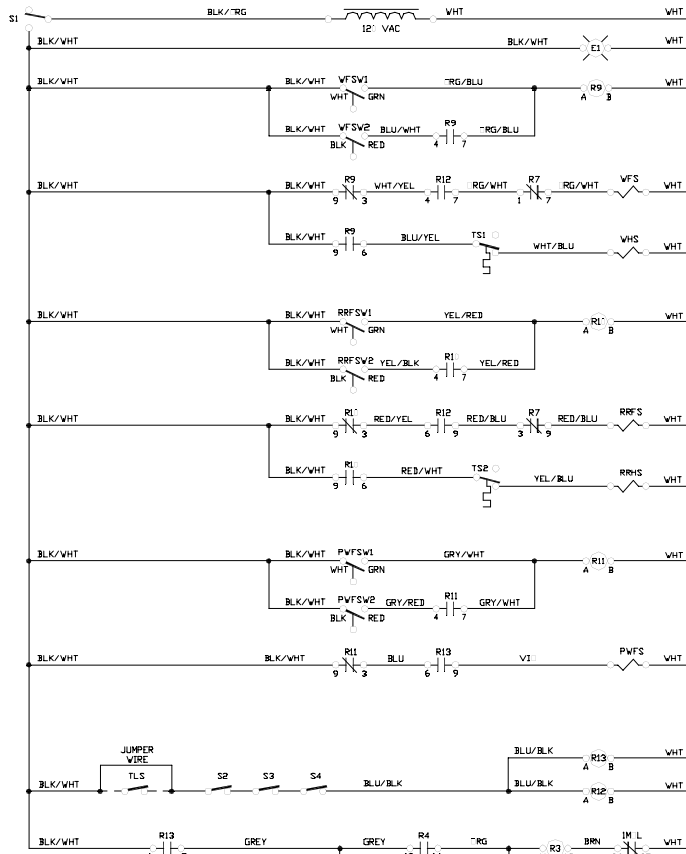

### LEGEND

- L1 L2 L3 POWER DISTRIBUTION BLOCK
- GND GROUND
- R3 DRIVE MOTOR CONTACTOR
- R4 WASH PUMP MOTOR CONTACTOR
- R5 R - RINSE PUMP MOTOR CONTACTOR
- R6 FINAL RINSE RELAY #1
- R7 FINAL RINSE RELAY #2
- R8 PREWASH PUMP MOTOR CONTACTOR
- R9 WASH TANK FILL RELAY
- R1 RECIRCULATING RINSE TANK FILL RELAY
- R11 PRE-WASH TANK FILL RELAY
- R12 DETERGENT SAFETY SWITCH RELAY #1
- R13 DETERGENT SAFETY SWITCH RELAY #2
- M1 DRIVE MOTOR
- M2 WASH PUMP MOTOR
- M3 RECIRCULATING RINSE PUMP MOTOR
- M4 PRE-WASH PUMP MOTOR
- 1M<sup>L</sup> DRIVE MOTOR OVERLOAD
- 2M<sup>L</sup> WASH PUMP MOTOR OVERLOAD
- 3M<sup>L</sup> R - RINSE PUMP MOTOR OVERLOAD
- 4M<sup>L</sup> PRE-WASH PUMP MOTOR OVERLOAD
- FS CONTROL FUSE
- T1 CONTROL TRANSFORMER
- DET DETERGENT DISPENSER CONNECTION
- CVS CONSTANT VOLTAGE SIGNAL
- S1 POWER SWITCH
- S2 DETERGENT SAFETY SWITCH 1
- S3 DETERGENT SAFETY SWITCH 2
- S4 DETERGENT SAFETY SWITCH 3
- S5 WASH PUMP SWITCH 1
- S6 WASH PUMP SWITCH 2
- S7 AUTO - MAN/DELIMIT SWITCH
- S8 RECIRCULATING RINSE PUMP SWITCH
- S9 FINAL RINSE SWITCH
- S1 PRE-WASH PUMP SWITCH
- E1 POWER LIGHT
- WFSW1 WASH FLAT SWITCH 1
- WFSW2 WASH FLAT SWITCH 2
- RRFSW1 RECIRCULATING RINSE FLAT SWITCH 1
- RRFSW2 RECIRCULATING RINSE FLAT SWITCH 2
- PWFSW1 PRE-WASH FLAT SWITCH 1
- PWFSW2 PRE-WASH FLAT SWITCH 2
- TS1 WASH REGULATING THERMISTAT
- TS2 R - RINSE REGULATING THERMISTAT
- CWTS COLD WATER THERMISTAT (PTI NAL)
- CWV COLD WATER VALVE (PTI NAL)
- TLS TABLE LIMIT SWITCH (PTI NAL)
- VFS WASH FILL SIGNAL ID
- VHS WASH HEAT SIGNAL ID
- RRFS RECIRCULATING RINSE FILL SIGNAL ID
- RRHS RECIRCULATING RINSE HEAT SIGNAL ID
- PWFS PRE-WASH FILL SIGNAL ID
- RS FINAL RINSE SIGNAL ID

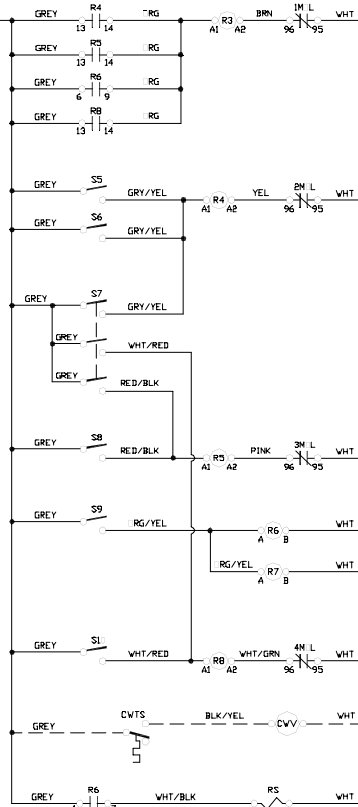

99-5-41-93-74

## SECTION 6: ELECTRICAL SCHEMATICS

### AJ-86CGP & AJ-100CGP (208-230 VOLTS, 60 HZ, SINGLE PHASE) PRIMARY SIDE

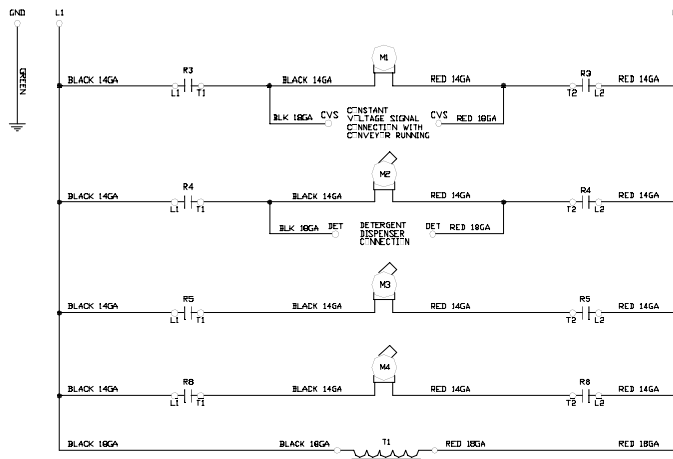

## SECTION 6: ELECTRICAL SCHEMATICS

### AJ-86CGP & AJ-100CGP (208-230 VOLTS, 60 HZ, SINGLE PHASE) SECONDARY SIDE

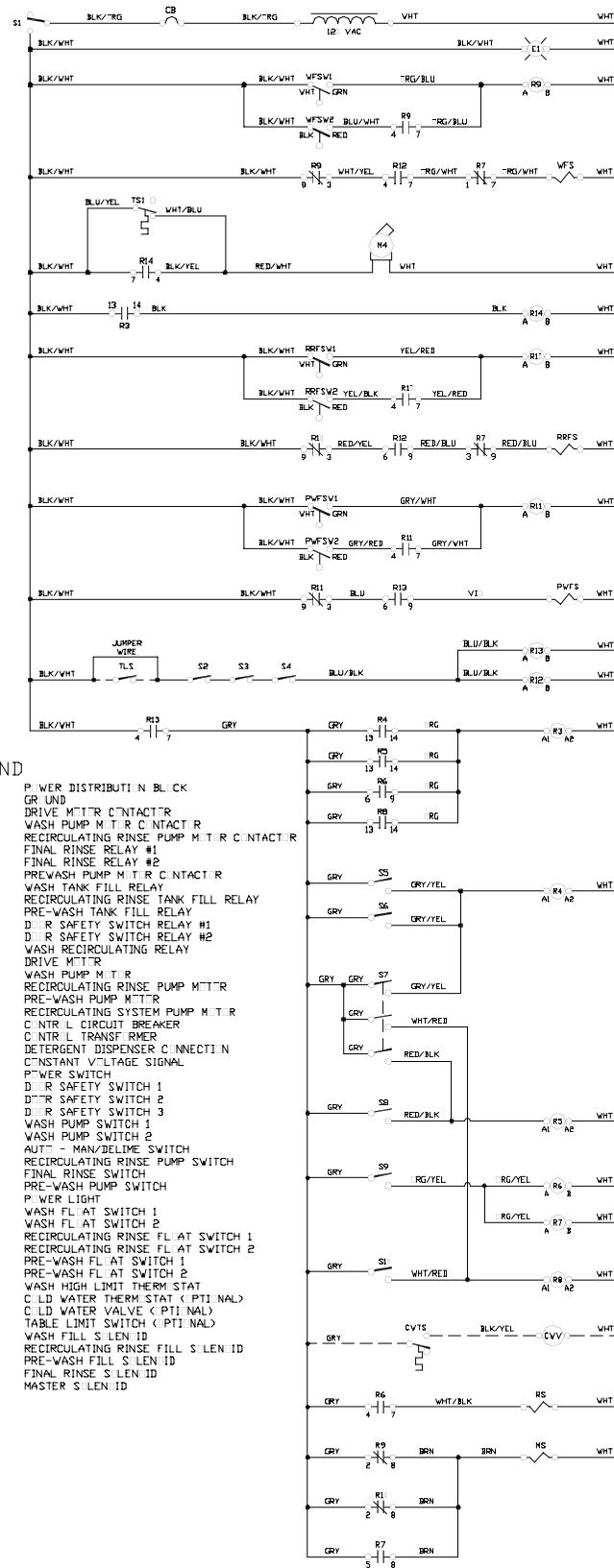

99 5--2-6--59.

## SECTION 6: ELECTRICAL SCHEMATICS

### AJ-86CGP & AJ-100CGP (208-230 VOLTS, 60 HZ, THREE PHASE) PRIMARY SIDE

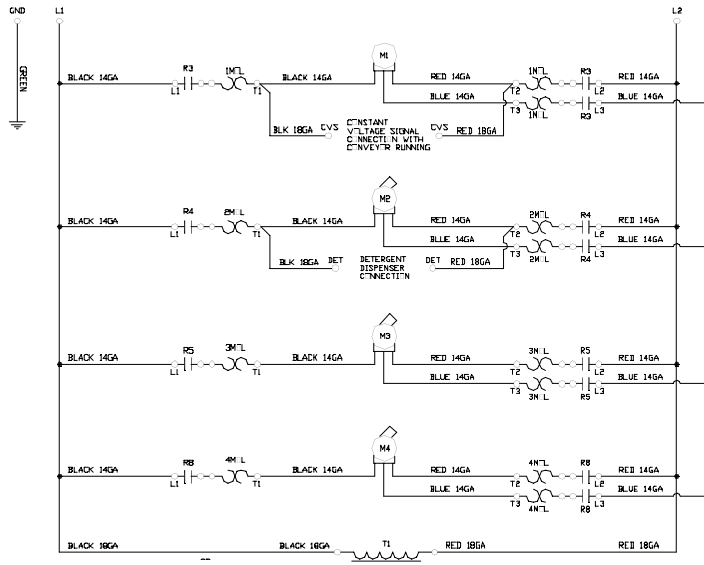

## SECTION 6: ELECTRICAL SCHEMATICS

### AJ-86CGP & AJ-100CGP (208-230 VOLTS, 60 HZ, THREE PHASE) SECONDARY SIDE

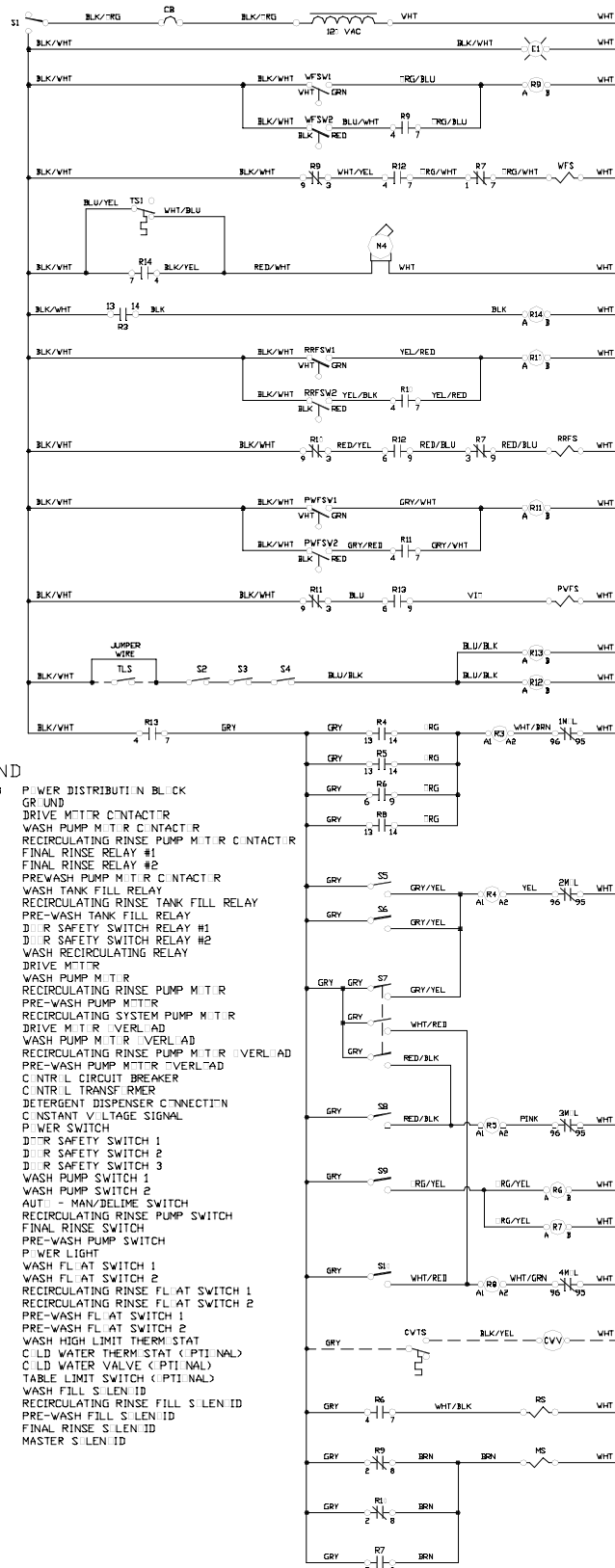

9915-41-06-74c

## SECTION 6: ELECTRICAL SCHEMATICS

### AJ-86CGP & AJ-100CGP (460 VOLTS, 60 HZ, THREE PHASE) PRIMARY SIDE

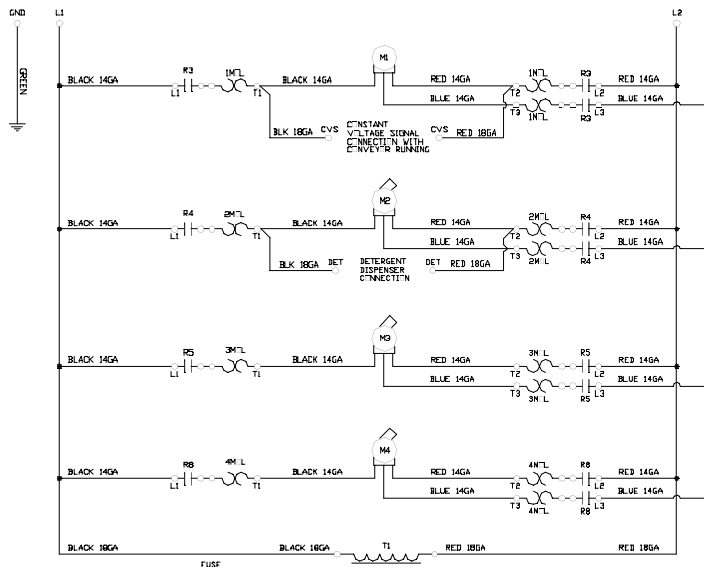

# SECTION 6: ELECTRICAL SCHEMATICS

## AJ-86CGP & AJ-100CGP (460 VOLTS, 60 HZ, THREE PHASE) SECONDARY SIDE

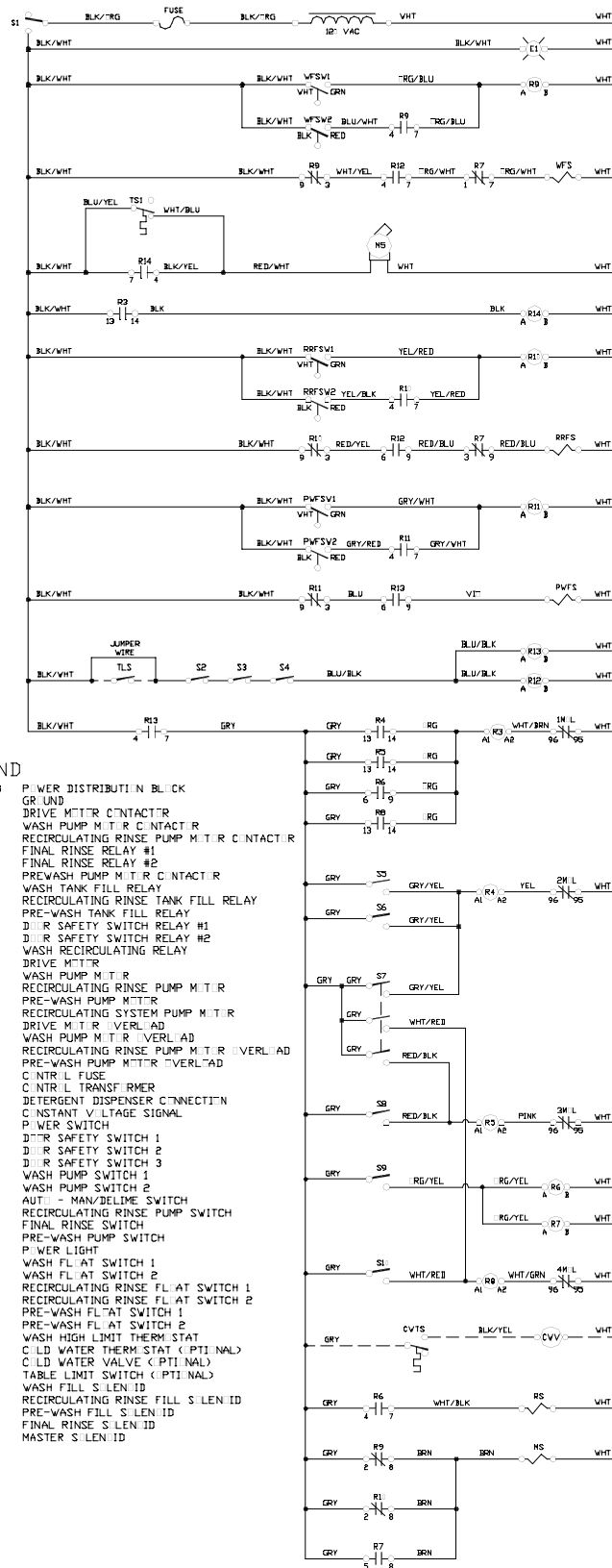

99'5-112-61-52

**SECTION 6: ELECTRICAL SCHEMATICS**  
**CONVEYOR EXHAUST FAN HOOKUP**

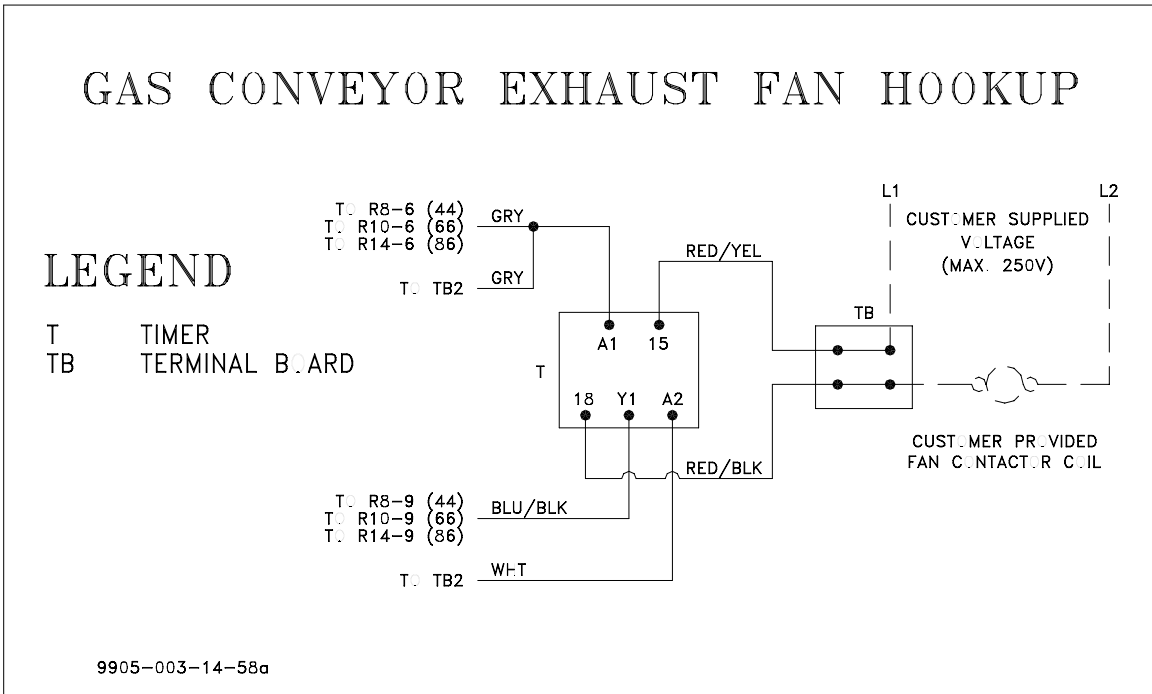
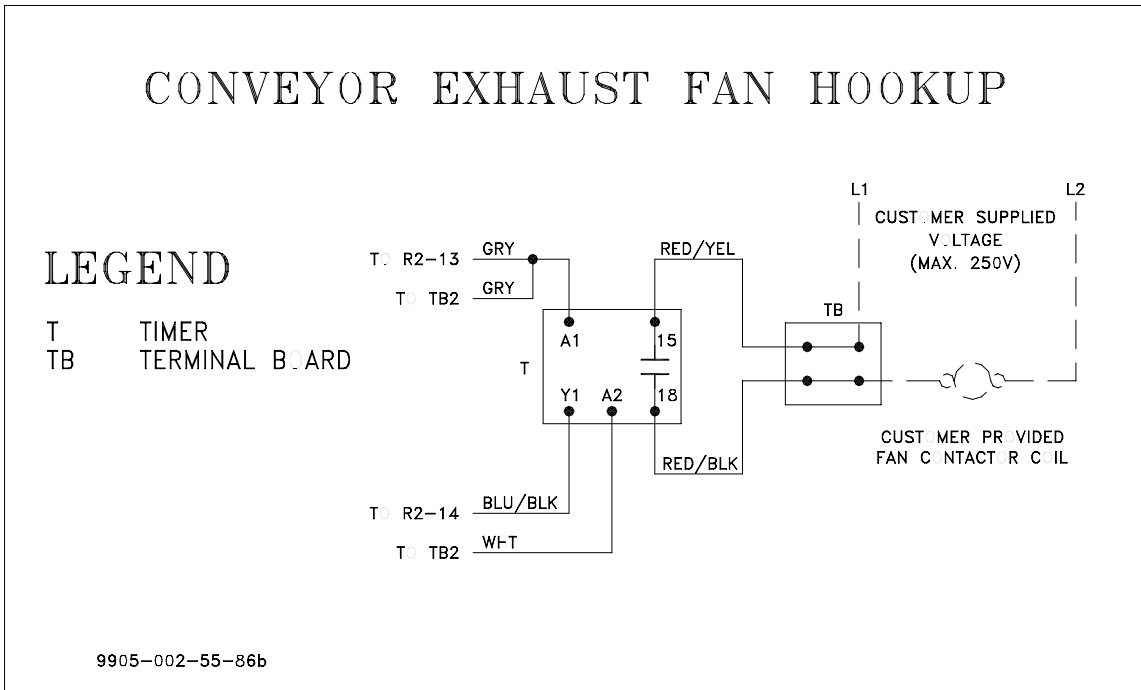



## SECTION 6: ELECTRICAL SCHEMATICS

### D226 STEAM BOOSTER/DRAIN QUENCH SYSTEM/SIDE LOADER

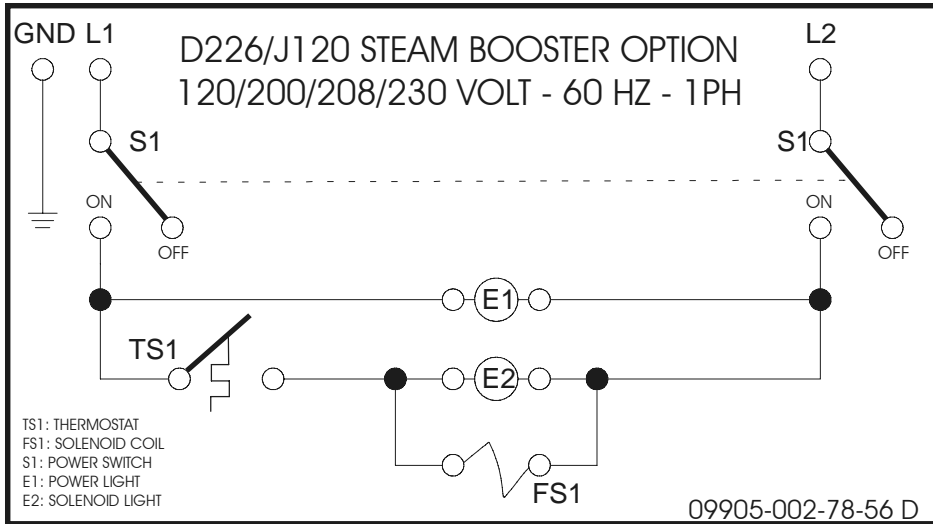

#### Drain Quench System

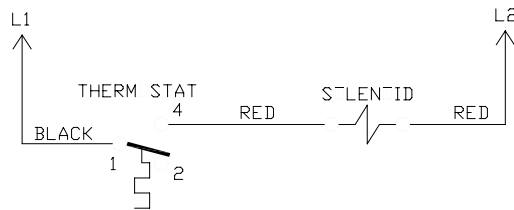

CONNECT BLACK WIRE TO THERM CONTACTOR - L1 WITH PIGGYBACK TERMINAL PROVIDED  
CONNECT WHITE WIRE TO THERM CONTACTOR - L2 WITH PIGGYBACK TERMINAL PROVIDED

## CONVEYOR SIDE LOADER

### 64" CONVEYORS

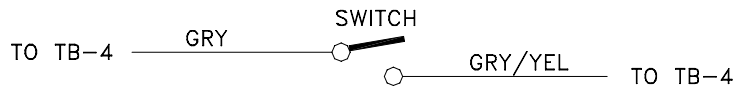

### 86" & 100" CONVEYORS

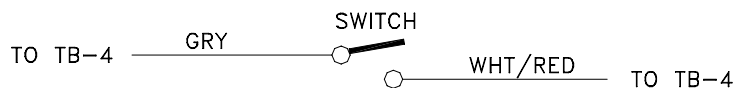

9905-002-56-84a

---

**SECTION 7:  
JACKSON MAINTENANCE  
& REPAIR CENTERS**

## SECTION 7: JACKSON MAINTENANCE & REPAIR CENTERS

### ALABAMA TO FLORIDA

#### ALABAMA

##### **JONES-McLEOD APPLIANCE SVC**

1616 7TH AVE. NORTH  
BIRMINGHAM, AL 35203  
(205) 251-0159  
800-821-1150  
FAX: (205) 322-1440  
service@jones-mcleod.com

##### **JONES-McLEOD APPLIANCE SVC**

854 LAKESIDE DRIVE  
MOBILE, AL 36693  
(251) 666-7278  
800-237-9859  
FAX: (251) 661-0223

#### ALASKA

##### **RESTAURANT APPLIANCE SERVICE**

7219 ROOSEVELT WAY NE  
SEATTLE, WA 98115  
(206) 524-8200  
800-433-9390  
FAX: (206) 525-2890  
info@restappl.com

#### ARIZONA

##### **AUTHORIZED COMMERCIAL FOOD EQMT. SVC**

4832 SOUTH 35TH STREET  
PHOENIX, AZ 85040  
(602) 234-2443  
800-824-8875  
FAX: (602) 232-5862  
acsboss@aol.com

##### **GCS SERVICE INC.**

PHOENIX, AZ  
(602) 474-4510  
800-510-3497  
FAX: (602) 470-4511

#### ARKANSAS

##### **BROMLEY PARTS & SVC**

10TH AND RINGO  
P.O. BOX 1688  
LITTLE ROCK, AR 72202  
(501) 374-0281  
800-482-9269  
FAX: (501) 374-8352  
service@bromleyparts.com  
parts@bromleyparts.com

##### **GCS SERVICE, INC.**

3717 CHERRY ROAD  
MEMPHIS, TN 38118  
(901) 366-4587  
800-262-9155  
FAX: (901) 366-4588

#### CALIFORNIA

##### **BARKERS FOOD MACHINERY SERVICES**

5367 SECOND STREET  
IRWINDALE, CA 91706  
(626) 960-9390  
800-258-6999  
FAX: (626) 337-4541  
service@barkers.com

##### **GCS SERVICE INC.**

LOS ANGELES, CA  
(213) 683-2090  
800-327-1433  
FAX: (213) 683-2099

##### **GCS SERVICE INC.**

SANTA ANA, CA  
(714) 542-1798  
800-540-0719  
FAX: (714) 542-4787

##### **GCS SERVICE INC.**

S. SAN FRANCISCO, CA  
(650) 635-0720  
800-969-4427  
FAX: (650) 871-4019

##### **COMMERCIAL APPLIANCE SERVICE, INC.**

6507 PACIFIC AVENUE, SUITE 102  
STOCKTON, CA 95207  
(916) 567-0203  
(800) 464-2222  
(916) 567-0266 FAX

##### **GCS SERVICE INC.**

SAN DIEGO, CA  
(858) 549-8411  
800-422-7278  
FAX: (858) 549-2323

##### **INDUSTRIAL ELECTRIC SVC.**

5662 ENGINEER DRIVE  
HUNTINGTON BEACH, CA 92649  
(714) 379-7100  
(800-457-3783  
FAX: (714) 379-7109

##### **P & D APPLIANCE SVC**

100 SOUTH LINDEN AVE.  
S. SAN FRANCISCO, CA 94080  
(650) 635-1900  
800-424-1414  
FAX: (650) 635-1919  
pndappl@aol.com

#### P & D APPLIANCE

4220-C ROSEVILLE ROAD  
NORTH HIGHLANDS, CA 95660  
(916) 974-2772  
800-824-7219  
FAX: (916) 974-2774

##### **COMMERCIAL APPLIANCE SERVICE, INC.**

281 LATHROP WAY, #100  
SACRAMENTO, CA 95815  
(916) 567-0203  
(800) 464-2222  
(916) 567-0324 FAX

#### COLORADO

##### **GCS SERVICE INC.**

SHERIDAN, CO  
(303) 371-9054  
800-972-5314  
FAX: (303) 371-4754

##### **HAWKINS COMMERCIAL APPLIANCE SERVICE**

3000 S. WYANDOT ST.  
ENGLEWOOD, CO 80110  
(303) 781-5548  
(800) 624-2117  
FAX: (303) 761-5561  
johns@hawkinscommercial.com

##### **METRO APPLIANCE SERVICE**

1640 S BROADWAY  
DENVER, CO 80210  
(303) 778-1126  
800-525-3532  
FAX: (303) 778-0268  
metroappls@aol.com

#### CONNECTICUT

##### **GCS SERVICE INC.**

HARTFORD, CT  
(860) 549-5575  
800-423-1562  
FAX: (860) 527-6355

##### **SUPERIOR KITCHEN SERVICE INC.**

22 THOMPSON ROAD  
WINDSOR, CT 06088  
(888) 590-1899  
(888) 590-1996 FAX

#### DELAWARE

##### **FOOD SERVICE EQMT.**

2101 PARKWAY SOUTH  
BROOMALL, PA 19008  
(610) 356-6900  
FAX: (610) 356-2038  
dancerule@aol.com

#### GCS SERVICE INC.

PHILADELPHIA, PA  
(215)925-6217  
800-441-9115  
FAX: (215) 925-6208

##### **ELMER SCHULTZ SERVICE**

36 BELMONT AVE.  
WILLMINGTON, DE 19804  
(302) 655-8900  
800-225-0599  
FAX: (302) 656-3673  
elmer2@erols.com

##### **EMR SERVICE DIVISION**

106 WILLIAMSPORT CIRCLE  
SALISBURY, MD 21804  
(410) 543-8197  
FAX: (410) 548-4038

#### FLORIDA

##### **COMMERCIAL APPLIANCE SERVICE**

8416 LAUREL FAIR CIRCLE  
BLDG 6, SUITE 114  
TAMPA, FL 33610  
(813) 663-0313  
800-282-4718  
FAX: (813) 663-0212  
commercialappliance@world-net.att.net

##### **GCS SERVICE INC**

MIAMI, FL  
(305) 621-6666  
800-766-8966  
FAX: (305) 621-6656

##### **GCS SERVICE INC**

ORLANDO, FL  
(407) 841-2551  
800-338-7322  
FAX: (407) 423-8425

##### **NASS PARTS AND SERVICE, INC.**

1144 BELVILLE ROAD, UNIT 359  
DAYTONA BEACH, FL 32114  
(386) 226-2642  
(800) 432-2795  
(386) 736-7695 FAX

##### **GCS SERVICE INC**

TAMPA, FL  
(813) 626-6044  
800-282-3008  
FAX: (813) 621-1174

## SECTION 7: JACKSON MAINTENANCE & REPAIR CENTERS

### FLORIDA TO MARYLAND

#### JONES-McLEOD APPLIANCE SVC

854 LAKESIDE DRIVE  
MOBILE, AL 36693  
(251) 666-7278  
800-237-9859  
FAX: (251) 661-0223  
service@jones-mcleod.com

#### NASS PARTS AND SERVICE, INC.

1108 SOUTH WOODS AVENUE  
ORLANDO, FL 32805  
(407) 425-2681  
(800) 432-2795  
(407) 425-3463 FAX

#### NASS PARTS AND SERVICE, INC.

1376 HEIDE AVENUE  
PALM BAY, FL 32907  
(321) 952-2012  
(800) 432-2795  
(321) 953-0266 FAX

#### GEORGIA

#### GCS SERVICE INC

ATLANTA, GA  
(770) 452-7322  
800-334-3599  
FAX: (770) 452-7473

#### HERITAGE FOODSERVICE

**GROUP OF ATLANTA**  
2100 NORCROSS PKWY.  
SUITE 130  
NORCROSS, GA 30071  
(770) 368-1465  
866-388-9837  
FAX: (866) 388-9838

#### WHALEY FOODSERVICE REPAIRS

109-A OWENS INDUSTRIAL DRIVE  
SAVANNAH, GA 31405  
(912) 447-0827  
888-765-0036  
FAX: (912) 447-0826

#### PIERCE PARTS & SERVICE

2422 ALLEN ROAD  
MACON, GA 31216  
(478) 781-6003  
800-368-2512  
FAX: (478) 781-7186

#### HAWAII

#### FOOD EQMT. PARTS & SERVICE CO.

300 PUUHALE RD.  
HONOLULU, HI 96819  
(808) 847-4871  
FAX: (808) 842-1560  
fepsco@hula.net

#### IDAHO

#### RESTAURANT APPLIANCE SVC.

7219 ROOSEVELT WAY NE  
SEATTLE, WA 98115  
(206) 524-8200  
800-433-9390  
FAX: (206) 525-2890  
info@restappl.com

#### RON'S SERVICE

703 E 44TH STREET STE 10  
GARDEN CITY, ID 83714  
(208) 375-4073  
FAX: (208) 375-4402

#### ILLINOIS

#### CONES REPAIR SVC.

2408 40TH AVE.  
MOLINE, IL 61265  
(309) 797-5323  
800-716-7070  
FAX: (309) 797-3631  
jackb@cones.com

#### EICHENAUER SERVICES INC.

130 S OAKLAND ST.  
DECATUR, IL 62522  
(217) 429-4229  
800-252-5892  
FAX: (217) 429-0226  
esi@esiquality.com

#### GCS SERVICE INC.

ELMHURST, IL  
(630) 941-7800  
800-942-9689  
FAX: (630) 941-6048

#### GCS SERVICE INC.

ST. LOUIS, MO  
(314) 683-7444  
800-284-4427  
FAX: (314) 638-0135

#### GENERAL PARTS, INC.

248 JAMES STREET  
BENSONVILLE, IL 60106  
(630) 595-3300  
(800) 880-3604  
FAX: (630) 595-0006

#### INDIANA

#### GCS SERVICE INC.

INDIANAPOLIS, IN  
(317) 545-9655  
800-727-8710  
FAX: (317) 549-6286

B622 LA PAS TRAIL

INDIANAPOLIS, IN 46268  
(317) 290-8060  
(800) 410-9794  
(317) 290-8085 FAX

#### IOWA

#### GOODWIN TUCKER GROUP

#### 2900 DELAWARE AVENUE

DES MOINES, IA 50317  
(515) 262-9308  
800-372-6066  
FAX: (515) 262-2936  
parts@goodwintucker.com

#### CONES REPAIR SVC.

1056 27TH AVENUE SW  
CEDAR RAPIDS, IA 52404  
(319) 365-3325  
800-747-3326  
FAX: (319) 365-0885

#### KANSAS

#### GCS SERVICE INC.

KANSAS CITY, MO  
(816) 920-5999  
800-229-6477  
FAX: (816) 920-7387

#### GENERAL PARTS, INC.

1101 E. 13TH STREET  
KANSAS CITY, MO 64106  
(816) 421-5400  
(800) 279-9967  
(816) 421-1270 FAX

#### KENTUCKY

#### CERTIFIED SERVICE CENTER

127 DISHMAN LANE  
BOWLING GREEN, KY 42101  
(270) 783-0012  
(877) 907-0012  
FAX: (270) 783-0058

#### CERTIFIED SERVICE CENTER

#### RAMCO BUSINESS PARK

4283 PRODUCE ROAD  
LOUISVILLE, KY 40218  
(502) 964-7007  
800-637-6350  
FAX: (502) 964-7202  
cwalker@certifiedsc.com  
droenigk@certifiedsc.com

#### CERTIFIED SERVICE CENTER

1051 GOODWIN DRIVE  
LEXINGTON, KY 40505  
(606) 254-8854  
800-432-9269  
FAX: (606) 231-7781  
jatkens@certifiedsc.com

#### GCS SERVICE INC.

LOUISVILLE, KY  
(502) 367-1788  
800-752-6160  
FAX: (502) 367-0400

#### GCS SERVICE INC.

LEXINGTON, KY  
(606) 255-0746  
800-432-9260  
FAX: (606) 255-0748

#### LOUISIANA

#### HERITAGE SERVICE GROUP

1532 RIVER OAKS WEST  
NEW ORLEANS, LA 70123  
(504) 734-8864  
(800) 499-2351  
(504) 733-2559 FAX

#### MAINE

#### GCS SERVICE INC.

CHELSEA, MA  
(617) 889-9393  
800-225-1155  
FAX: (617) 889-1222

#### MASSACHUSETTS RESTAU-

#### RANT SUPPLY

34 SOUTH STREET  
SOMERVILLE, MA 02143  
(617) 868-1930  
800-338-6737  
FAX: (617) 686-5331

#### PINE TREE FOOD EQUIP- MENT

175 LEWISTON ROAD  
GRAY, ME 04039  
(207) 657-6400  
(800) 540-5427  
(207) 657-5464 FAX

#### MARYLAND

#### EMR SERVICE DIVISION

700 EAST 25TH STREET  
BALTIMORE, MD 21218  
(410) 467-8080  
800-879-4994  
FAX: (410) 467-4191  
baltparts@emrco.com

## SECTION 7: JACKSON MAINTENANCE & REPAIR CENTERS

### MARYLAND TO NEW YORK

**EMR SERVICE DIVISION**  
106 WILLIAMSPORT CIRCLE  
SALISBURY, MD 21804  
(410) 543-8197  
888-687-8080  
FAX: (410) 548-4038  
baltparts@emrco.com

**EMR SERVICE DIVISION**  
5316 Sunnyside Ave.  
Beltsville, MD 20715  
(301) 931-7000  
800-348-2365  
FAX: (301) 931-3060  
baltparts@emrco.com

**GCS SERVICE INC.**  
SILVER SPRING, MD  
(301) 585-7550 (DC)  
(410) 792-0338 (BALT)  
(800) 638-7278  
FAX: (301) 495-4410

#### MASSACHUSETTS

**ACE SERVICE CO.**  
95 HAMPTON AVE.  
NEEDHAM, MA 02494  
(781) 449-4220  
800-225-4510 MA & NH  
FAX: (781) 444-4789  
taceservice@aol.com

**MASSACHUSETTS RESTAU-  
RANT SUPPLY**  
34 SOUTH STREET  
SOMERVILLE, MA 02143  
(617) 868-1930  
800-338-6737  
FAX: (617) 868-5331

**GCS SERVICE INC.**  
CHELSEA, MA  
(617) 889-9393  
800-225-1155  
FAX: (617) 889-1222

**GCS SERVICE INC.**  
HARTFORD, CT  
(860) 549-5575  
800-723-1562  
FAX: (860) 527-6355

**SUPERIOR KITCHEN SER-  
VICE INC.**  
399 FERRY STREET  
EVERETT, MA 02149  
(617) 389-1899  
(888) 590-1899  
(617) 389-1996 FAX

#### MICHIGAN

**GCS SERVICE INC.**  
LIVONIA, MI  
(248) 426-9500  
800-772-2936  
FAX: (248) 426-7555

**JACKSON SERVICE COMPA-  
NY**  
3980 BENSTEIN RD.  
COMMERCE TWSHP, MI 48382  
(248) 363-4159  
800-332-4053  
FAX: (248) 363-5448

**GCS SERVICE INC.**  
GRAND RAPIDS, MI  
(616) 241-0200  
800-823-4866  
FAX: (616) 241-0541

#### MINNESOTA

**GCS SERVICE INC.**  
MINNEAPOLIS, MN  
(612) 546-4221  
800-345-4221  
FAX: (612) 546-4286

**GENERAL PARTS, INC.**  
11311 HAMPSHIRE AVENUE  
SOUTH  
BLOOMINGTON, MN 55438-  
2456  
(952) 944-5800  
(800) 279-9980  
(800) 279-9980 FAX

#### MISSISSIPPI

**GCS SERVICE INC.**  
JACKSON, MS  
(601) 956-7800  
800-274-5954  
FAX: (601) 956-1200

**GCS SERVICE INC.**  
MEMPHIS, TN  
(901) 366-4587  
800-262-9155  
FAX: (901) 366-4588

#### MISSOURI

**GCS SERVICE INC.**  
KANSAS CITY, MO  
(816) 920-5999  
800-229-6477  
FAX: (816) 920-7387

**GCS SERVICE INC.**  
ST. LOUIS, MO  
(314) 638-7444  
800-284-4427  
FAX: (314) 638-0135

**KAEMMERLIN PARTS & SVC.**  
2728 LOCUST STREET  
ST. LOUIS, MO 63103  
(314) 535-2222  
FAX: (314) 535-6205  
petek@kps.stl.com

**GENERAL PARTS, INC.**  
1101 EAST 13TH STREET  
KANSAS CITY, MO 64106  
(816) 421-5400  
(800) 279-9967  
(816) 421-1270 FAX

#### MONTANA

**RESTAURANT APPLIANCE  
SVC.**  
7219 ROOSEVELT WAY NE  
SEATTLE, WA 98115  
(206) 524-8200  
800-433-9390  
FAX: (206) 525-2890  
info@restappl.com

#### NEBRASKA

**GOODWIN - TUCKER GROUP**  
7535 D STREET  
OMAHA, NE 68124  
(402) 397-2880  
800-228-0342  
FAX: (402) 397-2881  
askme@goodwintucker.com

#### NEVADA

**HI TECH COMMERCIAL SER-  
VICE**  
1840 STELLA LAKE STREET  
NORTH LAS VEGAS, NV 89106  
(702) 649-4616  
(877) 924-4832  
FAX: (702) 649-4607  
larry@hitechnv.com

5454 LOUIE LANE  
RENO, NV 89511  
(775) 852-9696  
FAX: (775) 852-5104

**GCS SERVICE INC.**  
LAS VEGAS, NV  
(702) 450-3495  
800-500-9060  
FAX: (702) 450-3491

#### NEW HAMPSHIRE

**GCS SERVICE INC.**  
CHELSEA, MA  
(617)889-9393  
800-225-1155  
FAX: (617) 889-1222

**ACE SERVICE CO.**  
95 HAMPTON AVE.  
NEEDHAM, MA 02494  
(781) 449-4220  
800-225-4510 MA & NH  
FAX: (781) 444-4789  
taceservice@aol.com

**MASSACHUSETTS RESTAU-  
RANT SUPPLY**  
34 SOUTH STREET  
SOMERVILLE, MA 02143  
(617) 868-1930  
800-338-6737  
FAX: (617) 868-5331

#### NEW JERSEY

**JAY HILL REPAIRS**  
90 CLINTON RD.  
FAIRFIELD, NJ 07004  
(973) 575-9145  
800-836-0643  
FAX: (973) 575-5890  
jhrepair@aol.com

**GCS SERVICE INC.**  
EAST RUTHERFORD, NJ  
(973) 614-0003  
800-399-8294  
FAX: (973) 614-0230

**GCS SERVICE INC.**  
PHILADELPHIA, PA  
(215) 925-6217  
800-441-9115  
FAX: (215) 925-6208

**ELMER SCHULTZ SERVICES**  
201 W. WASHINGTON AVE.  
PLEASANTVILLE, NJ 08232  
(609) 641-0317  
800-378-1641  
FAX: (609) 641-8703  
elmer2@erols.com

#### NEW YORK

**APPLIANCE INSTALLATION  
AND SERVICE CORP.**  
1336 MAIN STREET  
BUFFALO, NY 14209  
(716) 884-7425  
800-722-1252  
FAX: (716) 884-0410  
ais@worldnet.att.net

## SECTION 7: JACKSON MAINTENANCE & REPAIR CENTERS

### NEW YORK TO PENNSYLVANIA

#### **B.E.S.T. INC.**

3003 GENESEE STREET  
BUFFALO, NY 14225  
(716) 893-6464  
800-338-5011  
FAX: (716) 893-6466  
bestserv@aol.com

#### **DUFFY'S EQUIPMENT SVC.**

3138 ONEIDA STREET  
SAUQUOIT, NY 13456  
(315) 737-9401  
800-443-8339  
FAX: (315) 737-7132  
duffyequip@aol.com

#### **NORTHERN PARTS & SVC.**

21 NORTHERN AVENUE  
PLATTSBURGH, NY 12903  
(518) 563-3200  
800-634-5005  
FAX: (800) 782-5424  
info@northernparts.com

#### **GCS SERVICE INC.**

BROOKLYN, NY  
(718) 486-5220  
800-969-4271  
FAX: (718) 486-6772

#### **ALL SERVICE KITCHEN**

EQUIPMENT REPAIR  
10 CHARLES ST.  
NEW HYDE PARK, NY 11040  
(516) 378-1176  
FAX: (516) 378-1735

#### **ALL ISLAND REPAIRS**

40-9 BURT DRIVE  
DEER PARK, NY 11729  
(631) 242-5588  
FAX: (631) 242-6102

#### **NORTH CAROLINA**

#### **AUTHORIZED APPLIANCE SERVICECENTER**

1020 TUCKASEEGEE RD.  
CHARLOTTE, NC 28208  
(704) 377-4501  
(800) 532-6127  
FAX:(704) 377-4504

#### **AUTHORIZED APPLIANCE SERVICECENTER**

800 N. PERSON ST.  
RALEIGH, NC 27604  
(919) 834-3476  
FAX:(919) 834-3477

#### **AUTHORIZED APPLIANCE SERVICECENTER**

904 S. MARSHALL ST.  
WINSTON-SALEM, NC 27403  
(336) 725-5396  
FAX:(336) 721-1289

#### **AUTHORIZED APPLIANCE SERVICECENTER**

104 HINTON AVE.  
WILMINGTON, NC 28403  
(910) 313-1250  
FAX:(910) 313-6130

#### **WHALEY FOODSERVICE**

8334-K ARROWRIDGE BLVD  
CHARLOTTE, NC 28273  
(704) 529-6242  
FAX: (704) 529-1558  
info@whaleyfoodservice.com

#### **WHALEY FOODSERVICE REPAIRS**

203-D CREEK RIDGE RD.  
GREENSBORO, NC 27406  
(336) 333-2333  
FAX: (336) 333-2533  
info@whaleyfoodservice.com

#### **WHALEY FOODSERVICE REPAIRS**

335-105 SHERWEE DRIVE  
RALEIGH, NC 27603  
(919) 779-2266  
FAX: (919) 779-2224  
info@whaleyfoodservice.com

#### **WHALEY FOODSERVICE REPAIRS**

6418-101 AMSTERDAM WAY  
WILMINGTON, NC 28405  
(910) 791-0000  
FAX: (910) 791-6662  
info@whaleyfoodservice.com

#### **NORTH DAKOTA**

#### **GCS SERVICE INC.**

MINNEAPOLIS, MN  
(612) 546-4221  
800-345-4221  
FAX: (612) 546-4286

#### **GENERAL PARTS, INC.**

10 SOUTH 18TH STREET  
FARGO, ND 58103  
(701) 235-4161  
(800) 279-9987  
(701) 235-0539 FAX

#### **OHIO**

#### **CERTIFIED SERVICE CENTER**

890 REDNA TERRACE  
CINCINNATI, OH 45215  
(513) 772-6600  
800-543-2060  
FAX: (513) 612-6600  
sbarasch@certifiedsc.com

#### **CERTIFIED SERVICE CENTER**

171J-K NORTH HAMILTON RD.  
COLUMBUS, OH 43213  
(614) 751-3769  
(866) 862-1252  
FAX: (614) 751-5792  
jadkins@certifiedsc.com

#### **CERTIFIED SERVICE CENTER**

6025 N. DIXIE DRIVE  
DAYTON, OH 45414  
(937) 898-4040  
(800) 257-2611  
FAX: (937) 898-4177  
dharvey@certifiedsc.com

#### **COMMERCIAL PARTS & SVC. OF COLUMBUS**

5033 TRANSAMERICA DRIVE  
COLUMBUS, OH 43228  
(614) 221-0057  
800-837-8327  
FAX: (614) 221-3622

#### **GCS SERVICE INC.**

COLUMBUS, OH  
(614) 476-3225  
800-282-5406  
FAX: (614) 476-1196

#### **ELECTRICAL APPLIANCE REPAIR SVC.**

5805 VALLEY BELT ROAD  
CLEVELAND, OH 44131  
(216) 459-8700  
800-621-8259  
FAX: (216) 459-8707  
tomr@electapprep.com

#### **OKLAHOMA**

#### **HAGAR RESTAURANT EQMT.**

1229 W MAIN STREET  
OKLAHOMA CITY, OK 73106  
(405) 235-2184  
800-445-1791  
FAX: (405) 236-5592

#### **OREGON**

#### **RON'S SERVICE**

16364 SW 72ND AVE  
PORTLAND, OR 97224  
(503) 624-0890  
800-851-4118  
FAX: (503) 684-6107  
robinson@ronsservice.com

#### **PENNSYLVANIA**

#### **A.I.S. COMMERCIAL PARTS & SERVICE**

1816 WEST 26TH STREET  
ERIE, PA 16508  
(814) 456-3732  
800-332-3732  
FAX: (814) 452-4843  
aiserie@aol.com

#### **ELMER SCHULTZ SVC.**

540 NORTH 3RD STREET  
PHILADELPHIA, PA 19123  
(215) 627-5400  
FAX: (215) 627-5408  
elmer2@erols.com

#### **GCS SERVICE INC.**

PHILADELPHIA, PA  
(215) 925-6217  
800-441-9115  
FAX: (215) 925-6208

#### **GCS SERVICE INC.**

HARRISBURG, PA  
(717) 564-3282  
800-367-3225  
FAX: (717) 564-9286

#### **GCS SERVICE INC.**

PITTSBURGH, PA  
(412) 787-1970  
800-738-1221  
FAX: (412) 787-5005

#### **K & D PARTS AND SERVICE CO.**

1833-41 N CAMERON STREET  
HARRISBURG, PA 17103  
(717) 236-9039  
800-932-0503  
FAX: (717) 238-4367  
kdparts-service@paonline.com

#### **CLARK SERVICE & PARTS**

306 AIRPORT DRIVE  
BOX 10  
SMOKETOWN, PA 17576  
(717) 392-5590  
(717) 392-5735

## SECTION 7: JACKSON MAINTENANCE & REPAIR CENTERS

### RHODE ISLAND TO WISCONSIN

#### RHODE ISLAND

**GCS SERVICE INC.**  
EAST PROVIDENCE, RI  
(401) 434-6803  
800-462-6012  
FAX: (401) 438-9400

#### SUPERIOR KITCHEN SERVICE INC.

669 ELMWOOD AVENUE  
PROVIDENCE, RI 02907  
(888) 590-1899  
(401) 781-1996 FAX

#### SOUTH CAROLINA

#### AUTHORIZED APPLIANCE SERVICECENTER

1811 TAYLOR ST.  
COLUMBIA, SC 29202  
(803) 254-8414  
FAX: (803) 254-5146

#### AUTHORIZED APPLIANCE SERVICECENTER

2249 AUGUSTA RD.  
GREENVILLE, SC 29605  
(864) 235-9616  
FAX: (864) 235-9623

#### WHALEY FOODSERVICE REPAIRS

I 26&US1  
P.O. BOX 4023  
WEST COLUMBIA, SC 29170  
(803) 791-4420  
800-877-2662  
FAX: (803) 794-4630  
info@whaleyfoodservice.com

#### WHALEY FOODSERVICE REPAIRS

748 CONGAREE ROAD  
GREENVILLE, SC 29607  
(864) 234-7011  
800-494-2539  
FAX: (864) 234-6662  
info@whaleyfoodservice.com

#### WHALEY FOODSERVICE REPAIRS

1406-C COMMERCE PL.  
MYRTLE BEACH, SC 29577  
(843) 626-1866  
FAX: (843) 626-2632  
info@whaleyfoodservice.com

#### WHALEY FOODSERVICE REPAIRS

4740-A FRANCHISE STREET  
N. CHARLESTON, SC 29418  
(843) 760-2110  
FAX: (843) 760-2255  
info@whaleyfoodservice.com

#### SOUTH DAKOTA

#### GCS SERVICE INC.

MINNEAPOLIS, MN  
(612) 546-4221  
800-345-4221  
FAX: (612) 546-4286

#### GENERAL PARTS, INC.

10 SOUTH 18TH STREET  
FARGO, ND 58103  
(701) 235-4161  
(800) 279-9987  
(701) 235-0539 FAX

#### TENNESSEE

#### GCS SERVICE INC.

MEMPHIS, TN  
(901) 366-4587  
800-262-9155  
FAX: (901) 366-4588

#### GCS SERVICE INC.

NASHVILLE, TN  
(615) 244-8050  
800-831-7174  
FAX: (615) 244-8885

#### TEXAS

#### ARMSTRONG REPAIR CENTER

5110 GLENMOUNT DRIVE  
HOUSTON, TX 77081  
(713) 666-7100  
800-392-5325  
FAX: (713) 661-0520  
gm@armstrongrepair.com

#### COMMERCIAL KITCHEN REPAIR CO.

1377 N BRAZOS  
P.O BOX 831128  
SAN ANTONIO, TX 78207  
(210) 735-2811  
800-292-2120  
FAX: (210) 735-7421  
brock@commercialkitchen.com

#### GCS SERVICE INC.

DALLAS, TX  
(972) 484-2954  
800-442-5026  
FAX: (972) 484-2531

#### GCS SERVICE INC.

HOUSTON, TX  
(713)785-9187  
800-868-6957  
FAX: (713) 785-3979

#### GCS/STOVE PARTS

2120 SOLANA STREET  
FORT WORTH, TX 76117  
(817) 831-0381  
800-433-1804  
FAX: (817) 834-7754  
bud@stoveparts.com

#### UTAH

#### LA MONICA'S RESTAURANT EQMT. SVC.

6182 SOUTH STRATLER AVENUE  
MURRAY, UT 84107  
(801) 263-3221  
800-527-2561  
FAX: (801) 263-3229  
lamonica81@aol.com

#### VERMONT

#### NORTHERN PARTS & SVC.

4874 S. CATHERINE STREET  
PLATTSBURGH, NY 12901  
(518) 563-3200  
800-634-5005  
FAX: (800) 782-5424  
info@northernparts.com

#### GCS SERVICE INC.

CHELSEA, MA  
(617)889-9393  
800-225-1155  
FAX: (617) 889-1222

#### VIRGINIA

#### DAUBERS, INC.

7645 DYNATECH COURT  
SPINGFIELD, VA 22153  
(703) 866-3600  
800-554-7788  
FAX: (703) 866-4071  
daubers@aol.com

#### GCS SERVICE INC.

SILVER SPRING, MD  
(301) 585-7550(DC)  
(410) 792-0388(BALT)  
800-638-7278  
FAX: (301)495-4410

#### GCS SERVICE INC.

RICHMOND, VA  
(804) 672-1700  
800-899-5949  
FAX: (804) 672-2888

#### GCS SERVICE INC.

VIRGINIA BEACH, VA  
(757) 464-3500  
800-476-4278  
FAX: (757) 464-4106

#### WASHINGTON

#### GCS SERVICE INC.

SEATTLE, WA  
(206) 763-0353  
800-211-4274  
FAX: (206) 763-5943

#### RESTAURANT APPLIANCE SERVICE

7219 ROOSEVELT WAY, NE  
SEATTLE, WA 98115  
(206) 524-8200  
800-433-9390  
FAX: (206) 525-2890  
info@restappl.com

#### WEST VIRGINIA

#### STATEWIDE SERVICE, INC.

603 MAIN AVE.  
NITRO, WV 25143  
(304) 755-1811  
(800) 441-9739  
FAX: (304) 755-4001  
sws3182@aol.com

#### WISCONSIN

#### APPLIANCE SERVICE CENTER, INC.

2439 ATWOOD AVE  
MADISON, WI 53704  
(608) 246-3160  
800-236-7440  
FAX: (608) 246-2721  
ascmad@execpc.com

#### APPLIANCE SERVICE CENTER, INC.

6843 W. BELOIT RD.  
WEST ALLIS, WI 53219  
(414) 543-6460  
800-236-6460  
FAX: (414) 543-6480  
ascmil@execpc.com

#### APPLIANCE SERVICE CENTER

786 MORRIS AVE  
GREEN BAY, WI 54304  
(920) 496-9993  
800-236-0871  
FAX: (920) 496-9927  
ascfox@execpc.com

---

## SECTION 7: JACKSON MAINTENANCE & REPAIR CENTERS

### WISCONSIN TO WYOMING/INTERNATIONAL

#### GENERAL PARTS, INC.

W223 N735 SARATOGA DRIVE  
WAUKESHA, WI 53186  
(262) 650-6666  
(800) 279-9946  
(262) 650-6660 FAX

#### WYOMING

#### HAWKINS COMMERCIAL APPLIANCE SERVICE

3000 S. WYANDOT ST.  
ENGLEWOOD, CO 80110  
(303) 781-5548  
(800) 624-2117  
FAX: (303) 761-5561  
johns@hawkinscommercial.com

#### METRO APPLIANCE SERVICE

1640 S BROADWAY  
DENVER, CO 80210  
(303) 778-1126  
800-525-3532  
FAX: (303) 778-0268  
metroappls@aol.com

#### INTERNATIONAL

#### GLOBAL PARTS AND SUPPLY

7758 NW 72ND ST  
MIAMI, FL 33166  
(305) 885-6353

#### H.D. SHELDON AND CO

19 UNION SQUARE, WEST  
NEW YORK, NY 10003  
(212) 627-1759  
(212) 924-6920

#### CANADA

#### THE GARLAND GROUP

1177 KAMATO ROAD  
MISSISSAUGA, ONTARIO L4W  
1X4  
(905) 206-8380  
SALES  
(905) 624-1419  
FAX: (905) 624-1851  
SERVICE  
800-427-6668  
FAX: 800-361-7745

March 13, 2007



