

Project _____
 Item _____
 Quantity _____
 CSI Section 11400
 Approval _____
 Date _____

Models
TempStar®



Standard Features

- Sani-Sure™ feature assures proper rinse water temperature
- Multi-cycle timer (Extra Heavy, Heavy, Medium, Normal)
- Specially designed stainless steel nozzles provide superior cleaning action
- 17-1/4" (438 mm) door opening accepts 18" (457 mm) trays
- Interchangeable wash/rinse arms screw out for simple cleanup
- Auto-fill/auto-start
- Door switch
- Delime/manual wash switch
- Vent fan control - shuts vent fan off when machine is idle
- Low watt density electric wash tank heater
- Hi-limit thermostat and low water protection
- Top mounted controls for ease of operation
- Adjustable bullet feet
- Uses standard 20" X 20" (508 mm X 508 mm) racks
- Front dress panel
- Detergent/rinse additive signal connection fuse box
- Self-draining stainless steel pump
- Built-in 70° F (38.9° C) rise booster heater is standard; 40° F (22.2° C) rise booster heater is available but must be specified at time of order
- Large scrap basket

Mandatory Specs

- Specify:
- Electric
 - Steam
- Specify voltage _____
 Specify booster size _____

Options

- Optional 40° F (22.2° C) rise booster heater is available at no additional cost (must be specified)
- 480V Electrical
- Single Phase
- 1/2" Pressure Regulator
- Drain Quench System
- Scaltrol
- Water Hammer Arrestor
- Flanged Feet
- False Panel
- Door Interlock
- Steam Booster Heater
- Security Package

Accessories

- 36-Compartment Rack
 - 4-1/8" tall (105 mm)
 - 5-5/8" tall (143 mm)
 - 7" tall (178 mm)
- Combination Rack
- Peg Rack

Specifications

Uses 0.89 gallons (3 liters) of water per rack
 Total automatic (normal) cycle - 57 seconds
 58 racks per hour (normal) cycle
 1 hp wash pump motor
 Single point connections for all utilities

Field convertible from straight through to corner and vice versa

Field convertible from 3-phase to single-phase and vice versa

Durable stainless steel construction



Intertek



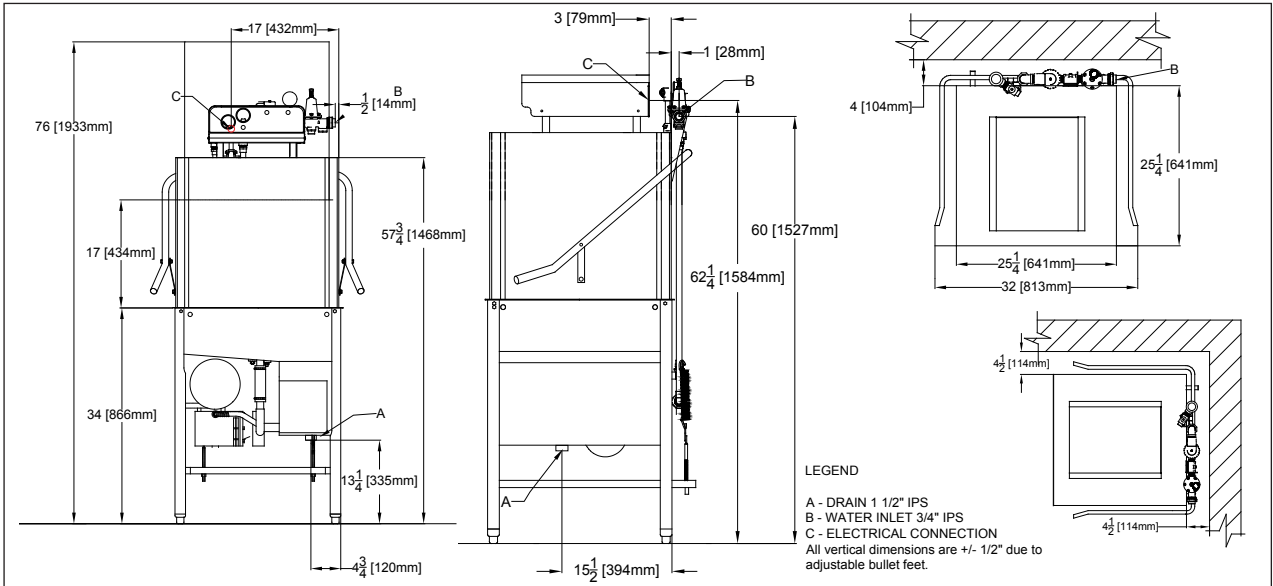

MODEL NO.	MACHINE DIMENSIONS			DRAIN HEIGHT	SHIPPING INFORMATION					
	HEIGHT	WIDTH	DEPTH		WEIGHT	CLASS	CUBE	HEIGHT	WIDTH	DEPTH
TempStar®	64-3/8" (1635 mm)	25-1/4" (641 mm)	25-1/4" (641 mm)	13-1/4" (335 mm)	350 lbs (159 kg)	92.5	37-1/2 cu. ft.	79" (2007 mm)	33" (838 mm)	43" (1092 mm)

DIMENSION REQUIREMENTS	
Wall Clearance (minimum)	4" (102 mm)
Standard Table Height	34" (864 mm)
Inside Clearance	17-1/4" (438 mm)
Machine Height with Door Open	76" (1933 mm)

STEAM REQUIREMENTS	
Steam Flow Pressure (PSIG)	15-20
Consumption @ 15 PSIG (lbs/hr)	45

OPERATING CAPACITY				
Racks per Hour	Normal 58	Medium 30	Heavy 20	Extra Heavy 12
OPERATING CYCLE (seconds)	Wash	Rinse	Dwell	Total Cycle
Normal	40	13	4	57
Medium	100	13	4	117
Heavy	160	13	4	177
Extra Heavy	280	13	4	297

WATER REQUIREMENTS	
Inlet Temperature	
40°F (22.2°C) Rise	140°F (60°C)
70°F (38.9°C) Rise	110°F (43°C)
No Booster	180°F (82°C)
Gallons per Hour	52 gal (197 L)
Gallons per Rack	.89 gal (3 L)
Waterline Size IPS (minimum)	1/2"
Drainline Size IPS (minimum)	1- 1/2"
Flow Pressure (PSI)	10
Wash Tank Capacity	8 gal (30 L)
Booster Tank Capacity	3 gal (11 L)

OPERATING TEMPERATURES	
Wash (minimum)	150° F (66° C)
Rinse (minimum)	180° F (82° C)

WASH PUMP MOTOR		
Wash Pump Motor Horsepower		1 HP
	Volts	KW
Electric Wash Tank Heater	208V	4.1
	230V	5.0
	460V	5.0
Electric Rinse Tank Heater - 40°F (22.2°C) Rise	208V	9.0
	230V	11.0
	460V	11.0
Electric Rinse Tank Heater - 70°F (38.9°C) Rise	208V	10.5
	230V	12.9
	460V	12.9

APPROXIMATE LOAD AMPS				
	No Booster	40°F (22.2°C) Rise	70°F (38.9°C) Rise	Steam
Power Supply	AMPS	AMPS	AMPS	AMPS
208V/60HZ/1PH	24.6	68.7	75.8	6A
208V/60HZ/3PH	16.3	42.1	46.3	6A
230V/60HZ/1PH	26.6	75.4	83.6	6A
230V/60HZ/3PH	17.5	45.5	50.7	6A
460V/60HZ/3PH	7.9	21.7	24.1	N/A

HOW TO SPECIFY: TempStar®

Jackson WWS, Inc.
 Shipping Address: 6209 North U.S. Highway 25E, Gray, KY 40734
 Mailing Address: P.O.Box 1060, Barbourville, KY 40906
 Telephone: 888-800-5672 • Fax: 606-523-1799
 Email: info@jacksonwws.com
 07610-002-66-59 [03/16/16]

www.jacksonwws.com