



*Warewashing Systems*

# INSTALLATION, OPERATION, AND SERVICE MANUAL

# AJ S E R I E S



**AJ SERIES CONVEYOR DISHMACHINES**

AJ-44 Series Manual • 07610-001-76-22-N

**MANUFACTURER'S LIMITED WARRANTY  
(APPLICABLE ONLY IN THE UNITED STATES AND CANADA)**

**WARRANTY REGISTRATION:**

To register your Jackson Dishmachine's warranty go to [www.jacksonwws-warranty.com](http://www.jacksonwws-warranty.com) or call 1-888-800-5672. Failure to register the Dishmachine will void the warranty.

**ONE YEAR LIMITED PARTS AND LABOR WARRANTY**

For a period of one (1) year from date of original installation of a new Jackson Dishmachine (but in no event to exceed eighteen (18) months from date of shipment from Jackson's factory), Jackson WWS, Inc. (Jackson) will repair or replace, at its discretion, any original part that proves defective in materials or workmanship at the time the Dishmachine was purchased; provided that (i) the Dishmachine has not been altered, (ii) the Dishmachine has been properly installed, maintained, and operated under normal use conditions and in accordance with the applicable installation, operation and service manual available on the Jackson website, and (iii) a warranty claim is reported to a Jackson Authorized Service Agency within the warranty period. This warranty includes replacement with Jackson specified genuine replacement parts, purchased directly from a Jackson Authorized Parts Distributor or Service Agency. Use of generic replacement parts may create a hazard and shall void this warranty.

**THIS WARRANTY DOES NOT APPLY OUTSIDE THE UNITED STATES AND CANADA.**

Jackson will pay the labor to repair or replace a defective original part as a part of the warranty, provided that a Jackson Authorized Service Agency performs the labor. Any repair or replacement work by anyone other than a Jackson Authorized Service Agency is the sole responsibility of the purchaser. Labor coverage is limited to regular hourly rates; Jackson will not pay overtime premiums or emergency service charges.

Accessory components (such as table limit switches, pressure regulators, and drain water tempering kits) that are not installed by Jackson at the factory and are shipped with the Dishmachine carry only a (1) one year parts warranty. Labor to repair or replace these components is not included in the warranty or covered by Jackson. Booster heaters not manufactured by Jackson are not covered by this warranty, but are warranted by their respective manufacturers.

This warranty is void if any defect or failure is a direct result from shipping, handling, fire, water, accident, alteration, modification, misuse, abuse, flood, acts of God, burglary, casualty, attempted repair by unauthorized persons, use of replacement parts not authorized by Jackson, improper installation, installation not in accordance with local electrical and plumbing codes, if the serial number has been removed or altered, if the Dishmachine is used for any purpose other than originally intended, or if the equipment is installed for residential use.

Jackson does not authorize any other entity or person, including, without limitation, any entity or person who deals in Jackson's Dishmachines, to change this warranty or create any other obligation in connection with Jackson's Dishmachines.

**TRAVEL LIMITATIONS:**

Jackson limits warranty travel time to the customer site within 50 miles of the Jackson authorized service agents office and during regular business hours. Jackson will not pay for travel time and mileage that exceeds these limits, or any fees such as those for air or boat travel without prior authorization.

**REPLACEMENT PARTS WARRANTY:**

For a period of (90) ninety days from the date of installation by a Jackson Authorized Service Agency (but in no event to exceed (180) one-hundred-eighty days from the date of purchase from a Jackson Authorized Parts Distributor or Service Agency), Jackson will repair or replace, at its discretion, any Jackson genuine replacement parts that prove defective in materials or workmanship at the time the replacement parts were installed. This warranty does not include paying the labor to repair or replace the replacement part. This warranty is subject to all conditions, exclusions and limitations applicable to the Dishmachine.

**MANUFACTURER'S LIMITED WARRANTY (CONT.)  
(APPLICABLE ONLY IN THE UNITED STATES AND CANADA)**

**PRODUCT CHANGES:**

Jackson reserves the right to make changes in design and specification of any component of the Dishmachine as engineering or necessity requires.

**DISCLAIMER OF WARRANTIES:**

**THERE ARE NO WARRANTIES, EXPRESSED OR IMPLIED, INCLUDING, WITHOUT LIMITATION, ANY IMPLIED WARRANTY OF FITNESS FOR A PARTICULAR PURPOSE OR MERCHANTABILITY, THAT ARE NOT SET FORTH HEREIN, OR THAT EXTEND BEYOND THE DURATION HEREOF.**

**LIMITATION OF REMEDIES AND LIABILITIES:**

**YOUR SOLE AND EXCLUSIVE REMEDY UNDER THIS LIMITED WARRANTY SHALL BE PRODUCT REPAIR OR REPLACEMENT AS PROVIDED HEREIN.**

**UNDER NO CIRCUMSTANCES WILL JACKSON BE LIABLE FOR ANY INCIDENTAL OR CONSEQUENTIAL DAMAGES, OR FOR DAMAGES IN THE NATURE OF PENALTIES. JACKSON'S LIABILITY ON ANY CLAIM OF ANY KIND WITH RESPECT TO THE GOODS OR SERVICES COVERED HEREUNDER SHALL IN NO CASE EXCEED THE PRICE OF THE GOODS OR SERVICES OR PART THEREOF WHICH GIVES RISE TO THE CLAIM.**

**ITEMS NOT COVERED:**

THIS WARRANTY DOES NOT COVER (1) ADJUSTMENTS INCLUDING, BUT NOT LIMITED TO, TIMER CAMS, THERMOSTATS, DOORS, TANK HEATER ADJUSTMENTS OR CLUTCHES; (2) AIR FREIGHT OR OVERNIGHT FREIGHT; (3) ANY AMOUNT EXCEEDING ORIGINAL PURCHASE PRICE; (4) CLEANING OF DRAIN VALVES, GAS LINES, RINSE/WASH NOZZLES, STRAINERS, SCREENS, OR SPRAY PIPES; (5) CLEANING OR DELIMING OF THE DISHMACHINE OR ANY COMPONENT INCLUDING, BUT NOT LIMITED TO, WASH ARMS, RINSE ARMS AND STRAINERS; (6) CONDITIONS CAUSED BY THE USE OF INCORRECT (NON-COMMERCIAL) GRADE DETERGENTS; (7) CORROSION FROM CHEMICALS DISPENSED IN EXCESS OF RECOMMENDED CONCENTRATIONS; (8) COSMETIC DAMAGE, INCLUDING BUT NOT LIMITED TO, SCRATCHES, DENTS, CHIPS, AND OTHER DAMAGE TO THE DISHMACHINE FINISHES, UNLESS SUCH DAMAGE RESULTS FROM DEFECTS IN MATERIALS AND WORKMANSHIP AND IS REPORTED TO JACKSON WITHIN (30) THIRTY DAYS FROM THE DATE OF INSTALLATION; (9) DAMAGE CAUSED BY LABOR DISPUTE; (10) DAMAGES RESULTING FROM IMPROPER CONNECTION TO UTILITY SERVICE; (11) DAMAGES RESULTING FROM WATER CONDITIONS, INADEQUATE OR EXCESSIVE WATER PRESSURE, ACCIDENTS, ALTERATIONS, IMPROPER USE, ABUSE, HANDLING, OVERLOADS, TAMPERING, IMPROPER INSTALLATION OR FAILURE TO FOLLOW MAINTENANCE AND OPERATING PROCEDURES; (12) DISCOLORATION, RUST OR OXIDATION OF SURFACES RESULTING FROM CAUSTIC OR CORROSIVE ENVIRONMENTS, INCLUDING, BUT NOT LIMITED TO, HIGH SALT CONCENTRATIONS, HIGH MOISTURE OR HUMIDITY, OR EXPOSURE TO CHEMICALS; (13) ELECTRIC BOOSTERS, FEED LINES, FLEX HOSE, FUSES, GARBAGE DISPOSALS, OR GAS PILOTS; (14) EXCESSIVE LIME, MINERAL, OR ALKALINE BUILDUP; (15) EXPENSES DUE TO DISCONNECTION, DELIVERY, RETURN AND REINSTALLATION; (16) FAILURE OF ELECTRICAL COMPONENTS DUE TO CONNECTION OF CHEMICAL DISPENSING EQUIPMENT INSTALLED BY OTHERS; (17) FAILURE OF FACILITY WATER HEATER TO MAKE TEMPERATURE; (18) FAILURE TO MAINTAIN WATER HARDNESS LOWER THAN 3.0 GRAINS, PH BETWEEN 7.0 AND 8.5 AND TOTAL DISSOLVED SOLIDS BELOW 250 PPM; (19) FAILURE TO COMPLY WITH LOCAL ELECTRICAL BUILDING CODES; (20) LEAKS OR DAMAGE RESULTING FROM SUCH LEAKS CAUSED BY THE INSTALLER, INCLUDING THOSE AT MACHINE TABLE CONNECTIONS, OR BY CONNECTION OF CHEMICAL DISPENSING EQUIPMENT INSTALLED BY OTHERS; (21) OPENING OR CLOSING OF UTILITY SUPPLY VALVES OR SWITCHING OF ELECTRICAL SUPPLY CURRENT; (22) PERFORMANCE OF REGULAR MAINTENANCE AND CLEANING AS OUTLINED IN THE OPERATOR'S GUIDE; (23) REMOVAL OR REINSTALLATION OF INACCESSIBLE DISHMACHINES OR BUILT-IN FIXTURES THAT INTERFERE WITH SERVICING, REMOVAL OR REPLACEMENT OF THE DISHMACHINE; (24) REPLACEMENT WEAR ITEMS INCLUDING, BUT NOT LIMITED TO, CURTAINS, DRAIN BALLS, DOOR GUIDES, GASKETS, O-RINGS, SEALS, SQUEEZE TUBES, AND BEARINGS; (25) RESIDENTIAL USE; (26) USE WITH UTILITY SERVICE OTHER THAN THAT DESIGNATED ON THE RATING PLATE.

## REVISION HISTORY

Revision Letter	Revision Date	Made by	Applicable ECNs	Details
D	5-14-04	CBW	N/A	Added exhaust fan hook-up schematic.
E	3-8-05	MAW	7096	Updated installation instructions. Added three instruction sheets for limit switches. Added instruction sheet for curtain installation. Changed layout.
F	1-13-06	CBW	7470	Added service kits and maintenance instructions.
G	1-26-06	MAW	7600	Added gas exhaust fan schematic and component kits.
H	3-21-06	MAW	7558 7571 7634	Added thermostat replacement kits. Added vent cowl assembly for hooded side-loader. Replaced rinse drain weldment. Added scrap basket strainer kit.
98	4-19-07	MAW	7898	Added 09905-003-32-20 fan load decal to the exhaust fan control kit. Added warranty pages and service centers listings.
35 & 36	5-3-07	MAW	7913	Added instructions and all necessary information for change of sanitization mode.
5-22, 111	8-29-07	MAW	N/A	Updated dimension pages. Removed alternate table limit swithes.
I	10-9-09	KJS	8044	Changed part 05700-021-67-50 to 09515-003-58-12.
J	1-16-14	MHH	QOF NDB-219	Updated manufacturer information.
K	3-23-15	KAP	N/A	Updated temperature on pgs. 13, 14, 19, and 20. Updated pressure regulator information on pgs. 30 and 45. Updated gas drawings on pgs. 7, 8, 13, 14, 19, and 20.
L	7-17-15	KAP	QOF-386	Updated drawing and P/N for suction weldment strainer on pg. 108.
M	8-4-15	KAP	N/A	Updated final rinse manifold P/N to 05700-031-74-88.
N	10-25-19	JH	8676	Updated manual to new format. Complete revision of manual. Added electrical requirements for available 380 V machines. Changed steam pressure to 10–30 PSI. Updated Item #7 on Motor page. Added 15 kW heater gasket on Heater page. Updated Item #11 on Curtains/Conveyor Switch page. Corrected callouts for inlet/outlet on System Connections page. Updated Item #5 on Recirculating Pump page.

The logo for Jackson Warewashing Systems features the word "Jackson" in a large, white, italicized serif font with a registered trademark symbol, set against a blue rounded rectangular background. Below this, the words "Warewashing Systems" are written in a smaller, blue, italicized sans-serif font.

# ***Jackson***<sup>®</sup>

## ***Warewashing Systems***

**AJ-44CGP, AJ-66CGP, AJ-80CGP**

**Gas-heated, hot-water-sanitizing  
rack conveyor machines.**

The manufacturer provides technical support for all of the machines detailed in this manual. We strongly recommend that you refer to this manual before making a call to our technical support staff. Please have this manual open when you call so that our staff can refer you, if necessary, to the proper page. Technical support is not available on holidays.

Contact technical support toll free at 1-888-800-5672.

Technical support is available for service personnel only.

# TABLE OF CONTENTS

## GUIDES

Symbols .....	1
Abbreviations & Acronyms .....	1

## SPECIFICATIONS

AJ-44 Dimensions .....	2
AJ-66 Dimensions .....	4
AJ-80 Dimensions .....	6
Side-loader Dimensions .....	8
Side-loader & Table Install .....	10
Operating Parameters .....	11
Electrical Requirements .....	12

## INSTALLATION

Installation Instructions .....	13
<i>Inspection</i> .....	13
<i>Unpacking</i> .....	13
<i>Leveling</i> .....	13
<i>Facility Hot Water Heater</i> .....	13
<i>Plumbing</i> .....	14
<i>Drain Line</i> .....	14
<i>Electrical Power Connections</i> .....	15
<i>Motor Rotation</i> .....	16
<i>Ventilation</i> .....	16
<i>Thermostats</i> .....	16
<i>Table Limit Switch Option</i> .....	16
<i>Chemical Feeder Equipment</i> .....	17
<i>Connection Points</i> .....	17
<i>Exhaust Fan Timer</i> .....	18
<i>Curtains</i> .....	19
<i>Hose Installation</i> .....	20

## OPERATION

Operating Instructions .....	21
<i>Preparation</i> .....	21
<i>Power Up</i> .....	21
<i>First Rack</i> .....	22
<i>Ware Preparation</i> .....	22
<i>Washing a Rack of Ware</i> .....	22
<i>Operational Inspection</i> .....	22
<i>Shutdown</i> .....	23
<i>Cleaning</i> .....	23
<i>Delimiting</i> .....	25

# TABLE OF CONTENTS

## MAINTENANCE

Preventative Maintenance .....	26
Torque Settings .....	26
Drive Gear Reducer Lubrication .....	27

## TROUBLESHOOTING

Troubleshooting .....	29
-----------------------	----

## PARTS

AJ-44 Control Box.....	31
AJ-66/80 Control Box.....	33
Motor Overloads .....	35
Frame/Panel .....	36
Plumbing Options .....	37
Pre-wash Plumbing.....	38
Plumbing.....	39
Rinse Header Plumbing .....	41
Wash Tank Coil .....	42
Coil Assembly .....	43
Tank Assembly .....	44
Recirculating Pump .....	45
System Connections.....	46
AJ-44 Drain Plumbing.....	47
AJ-66 Drain Plumbing, L-R .....	48
AJ-66 Drain Plumbing, R-L .....	49
Solenoid Valve & Vacuum Breaker .....	50
Drain Water Tempering Kit.....	51
Motor .....	52
Pre-wash & Wash Pumps .....	54
Pre-wash & Upper Wash Arm .....	55
Lower Wash Arm .....	56
Final Rinse .....	57
Doors.....	58
Drive Assembly.....	59
Pawl Bar Roller Bracket.....	61
Pawl Bars .....	62
AJ-44 Rack Rails .....	63
AJ-66 Rack Rails .....	64
Rinse Fill Option .....	66
Strainers .....	67
Manifolds.....	68
Float Switch/Scrap Basket.....	69
Curtains/Conveyor Switch .....	70
Side-loader Parts.....	71

# TABLE OF CONTENTS

## PARTS

Miscellaneous Parts .....	73
Go Box .....	75

## SCHEMATICS

### AJ-44CGP

208-230 V/60 Hz/1-Phase .....	76
208-230 V/60 Hz/3-Phase .....	77
460 V/60 Hz/3-Phase.....	78

### AJ-66CGP

208-230 V/60 Hz/1-Phase .....	79
208-230 V/60 Hz/3-Phase .....	80
380-460-600 V/60 Hz/3-Phase .....	81

Exhaust Fan.....	82
Side-loader .....	83



## SYMBOLS



- Risk of injury to personnel



- Risk of damage to equipment



- Risk of electrical shock



- Caustic chemicals



- Reference data plate



- Lockout electrical power

**NOTICE**

- Important note



- Instructions Hyperlink

## ABBREVIATIONS & ACRONYMS

**ANSI** - American National Standards Institute  
**CFM** - Cubic Feet per Minute  
**FPM** - Feet per Minute  
**GHT** - Garden Hose Thread  
**GPM** - Gallons per Minute  
**GPG** - Grains per Gallon  
**HP** - Horse Power  
**Hz** - Hertz  
**ID** - Inside Diameter  
**in/lbs** - Inch Pounds  
**kW** - Kilowatts  
**NFPA** - National Fire Protection Association  
**NPT** - National Pipe Thread  
**PSI** - Pounds per Square Inch  
**V** - Volts

## Left-to-Right

### LEGEND

- A - Water Inlet  
(3/4" NPT, 110-140 °F MIN)
- B - Electrical Connection
- C - Drain Connection (1 1/2" NPT)
- D - Vent Collar - Optional
- E - Vent Cowl - Standard
- F - Water Inlet for Booster  
(3/4" NPT, 110-140 °F)
- G - Water Outlet to Machine  
(3/4" NPT, 180 °F)
- H - Gas Connection (3/4" NPT)
- J - Vent Pipe Connection (4" OD)

All dimensions from the floor can be increased 1" using the machine's adjustable feet.

Items in red are not supplied with the machine.

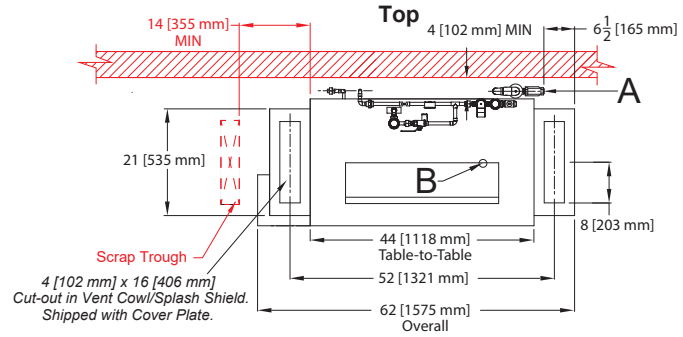

### Front

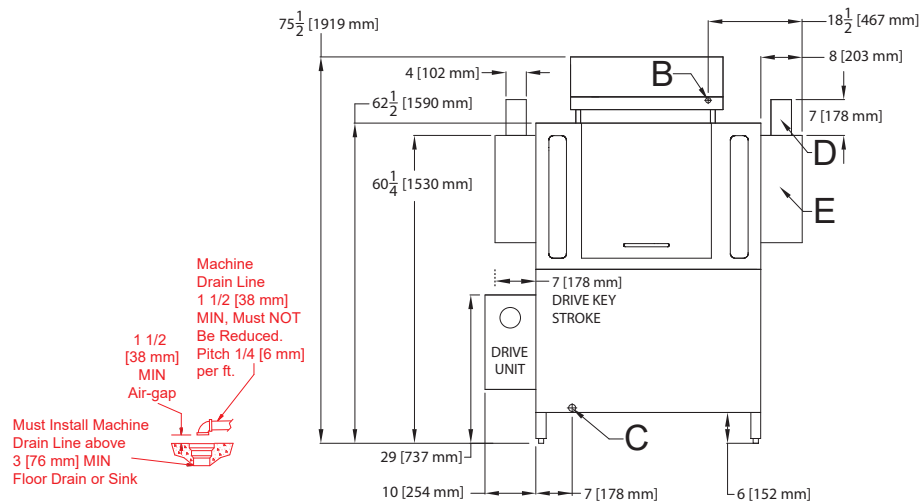

### Left

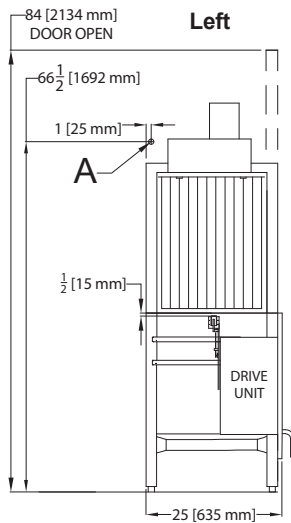

### Right

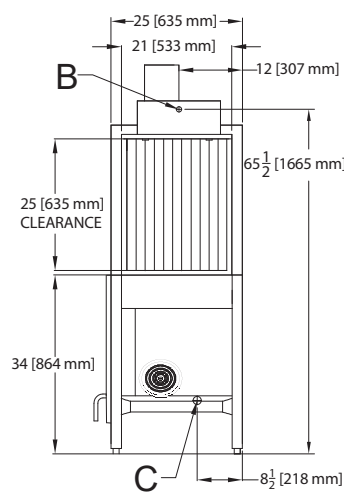

### Gas Booster

Gas Booster can be located anywhere, but must be 6 [154 mm] MIN from the machine.

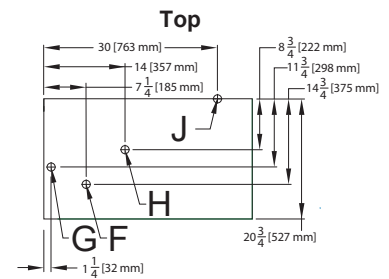

### Front

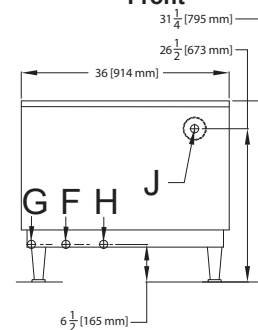

## Right-to-Left

### LEGEND

- A - Water Inlet (3/4" NPT, 110-140 °F MIN)
- B - Electrical Connection
- C - Drain Connection (1 1/2" NPT)
- D - Vent Collar - Optional
- E - Vent Cowl - Standard
- F - Water Inlet for Booster (3/4" NPT, 110-140 °F)
- G - Water Outlet to Machine (3/4" NPT, 180 °F)
- H - Gas Connection (3/4" NPT)
- J - Vent Pipe Connection (4" OD)

All dimensions from the floor can be increased 1" using the machine's adjustable feet.

Items in red are not supplied with the machine.

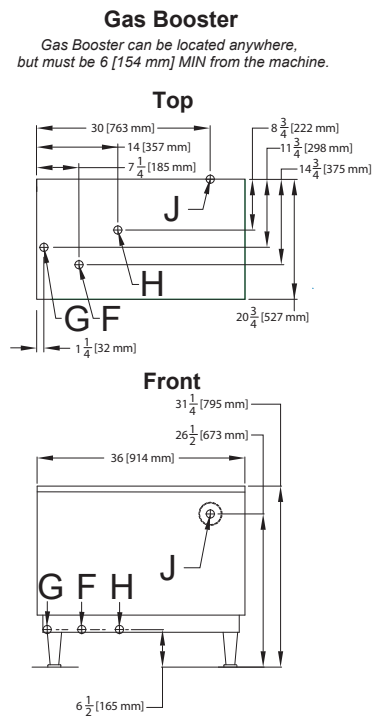
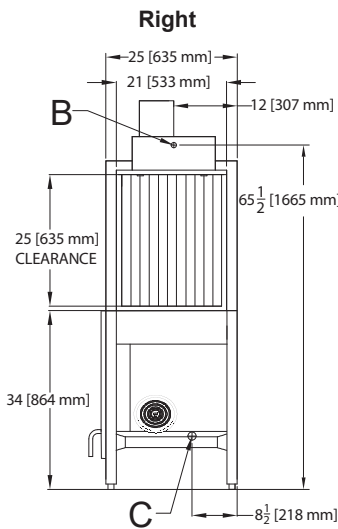
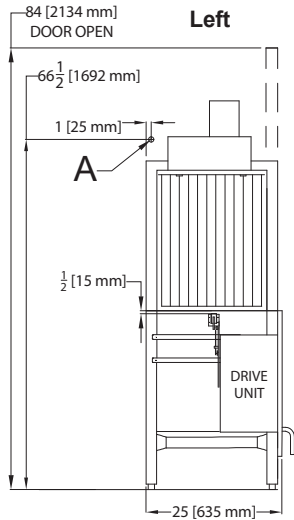
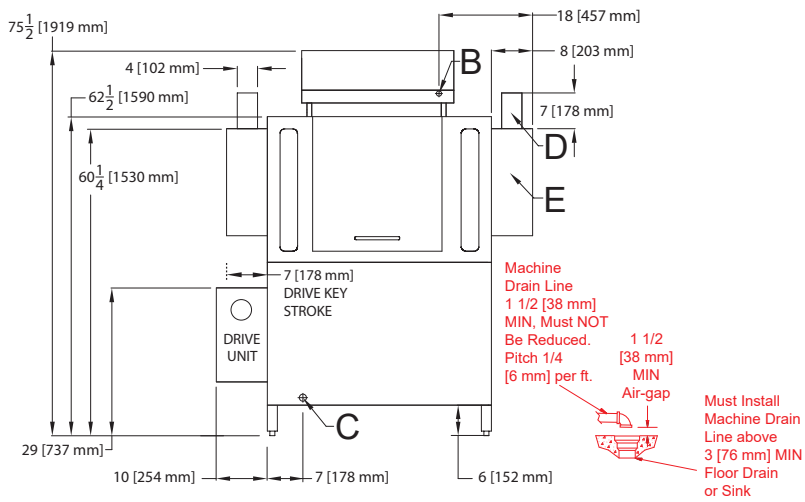
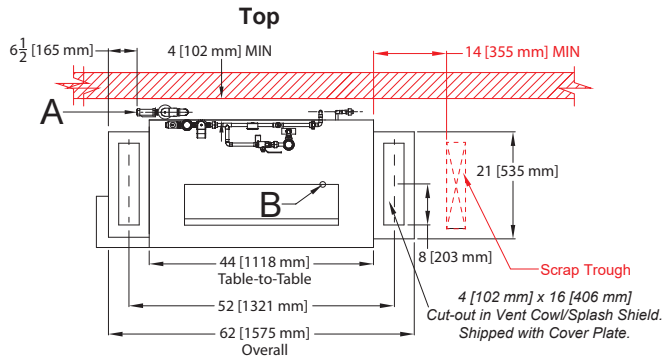

## Left-to-Right

### LEGEND

- A - Water Inlet  
(3/4" NPT, 110-140 °F MIN)
- B - Drain Connection  
(1 1/2" NPT)
- D - Vent Collar - Optional
- E - Vent Cowl - Standard
- F - Water Inlet for Booster  
(3/4" NPT, 110-140 °F)
- G - Water Outlet to Machine  
(3/4" NPT, 180 °F)
- H - Gas Connection (3/4" NPT)
- J - Vent Pipe Connection (4" OD)
- K - Pre-wash Water Inlet  
(3/4" NPT, 110-140 °F)
- L - Cold Water Thermostat - Optional  
(3/4" NPT)

All dimensions from the floor can be increased 1" using the machine's adjustable feet.

Items in red are not supplied with the machine.

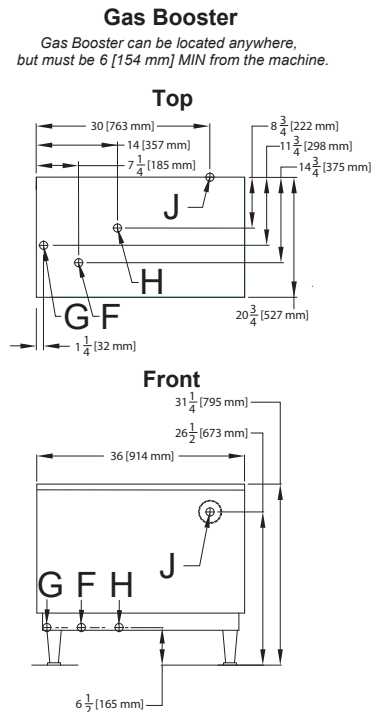
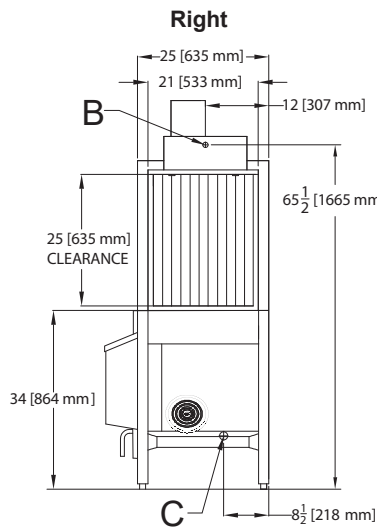
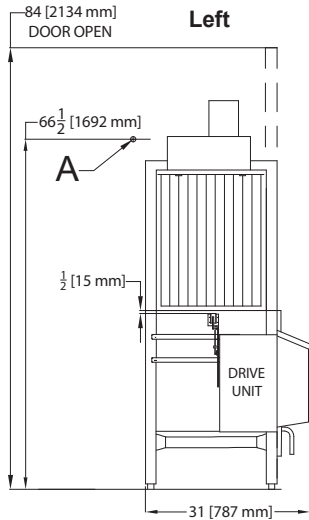
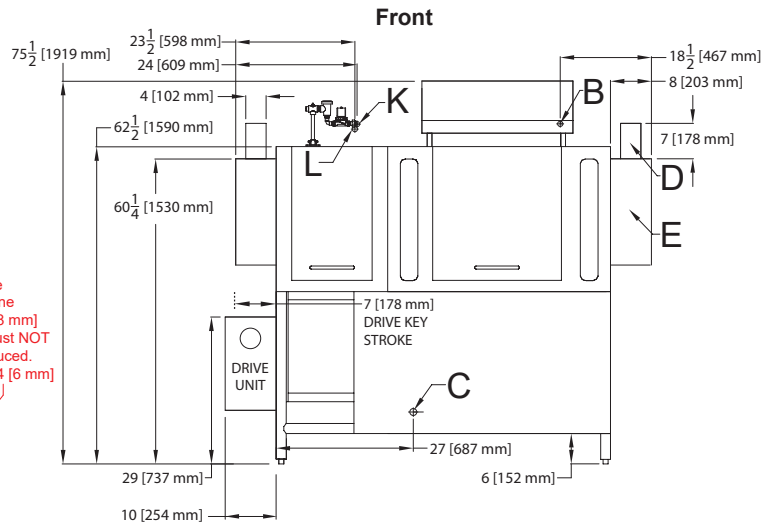
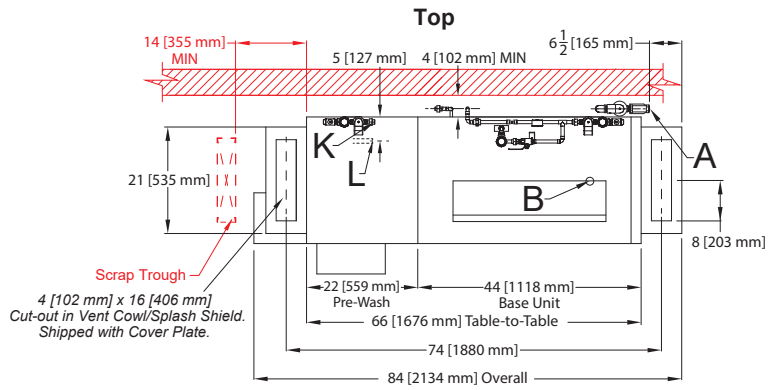

## Right-to-Left

### LEGEND

- A - Water Inlet  
(3/4" NPT, 110-140 °F MIN)
- B - Electrical Connection
- C - Drain Connection (1 1/2" NPT)
- D - Vent Collar - Optional
- E - Vent Cowl - Standard
- F - Water Inlet for Booster  
(3/4" NPT, 110-140 °F)
- G - Water Outlet to Machine  
(3/4" NPT, 180 °F)
- H - Gas Connection (3/4" NPT)
- J - Vent Pipe Connection (4" OD)
- K - Pre-wash Water Inlet  
(3/4" NPT, 110-140 °F)
- L - Cold Water Thermostat - Optional  
(3/4" NPT)

All dimensions from the floor can be increased 1" using the machine's adjustable feet.

Items in red are not supplied with the machine.

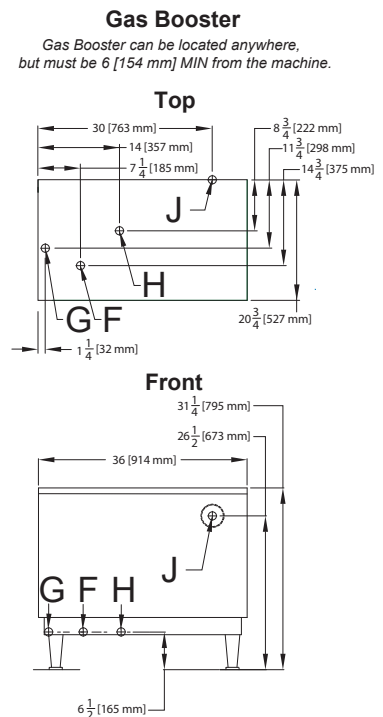
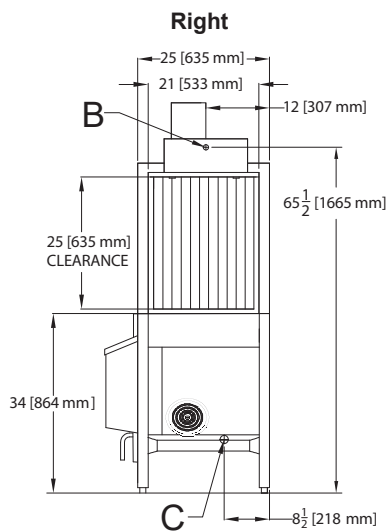
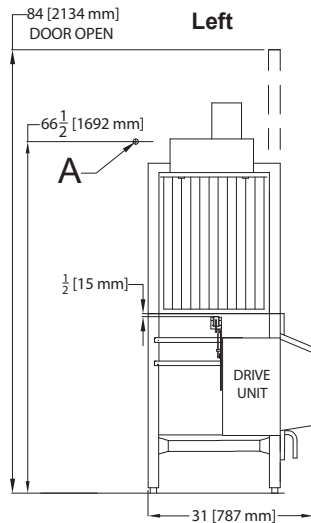
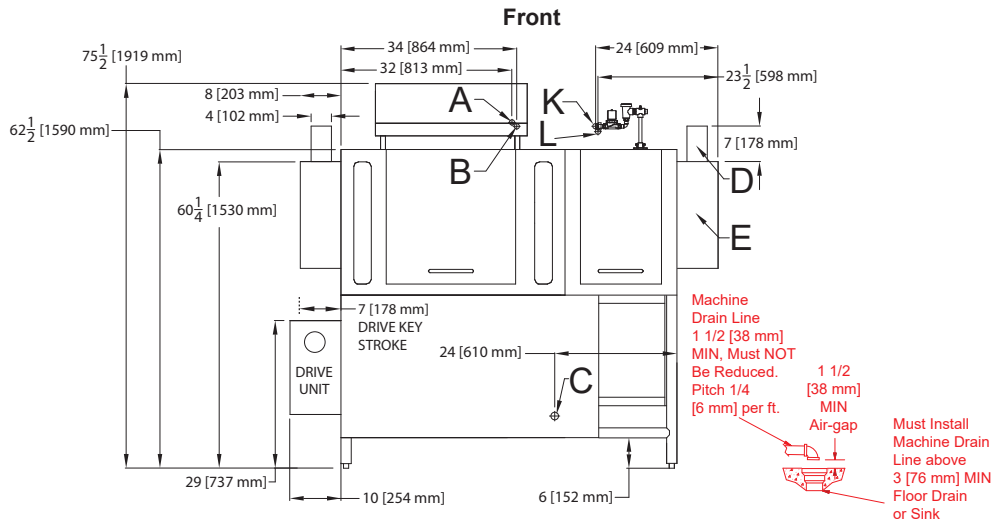
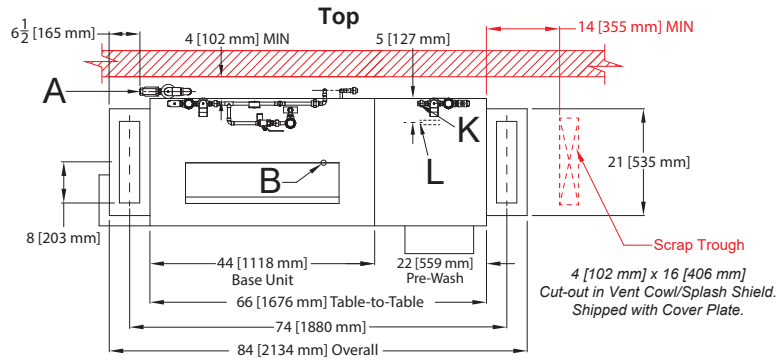

## Left-to-Right

### LEGEND

- A - Water Inlet  
(3/4" NPT, 110-140 °F MIN)
- B - Electrical Connection
- C - Drain Connection (1 1/2" NPT)
- D - Vent Collar - Optional
- E - Vent Cowl - Standard
- F - Water Inlet for Booster  
(3/4" NPT, 110-140 °F)
- G - Water Outlet to Machine  
(3/4" NPT, 180 °F)
- H - Gas Connection (3/4" NPT)
- J - Vent Pipe Connection (4" OD)
- K - Pre-wash Water Inlet  
(3/4" NPT, 110-140 °F)
- L - Cold Water Thermostat - Optional  
(3/4" NPT)

All dimensions from the floor can be increased 1" using the machine's adjustable feet.

Items in red are not supplied with the machine.

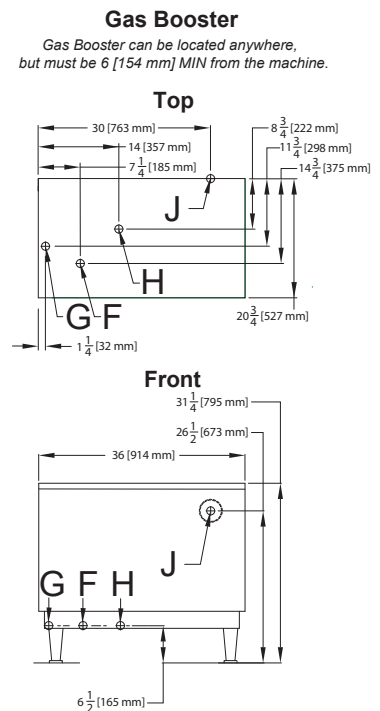
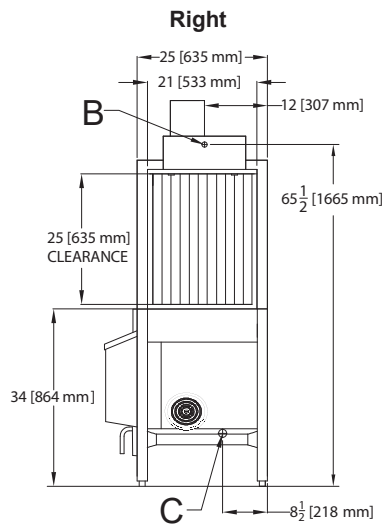
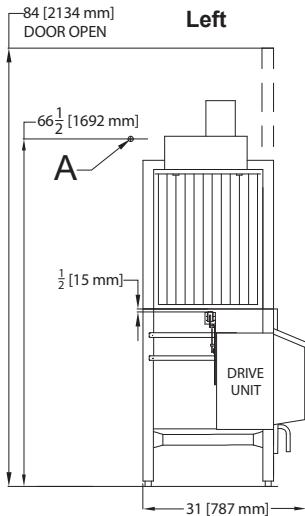
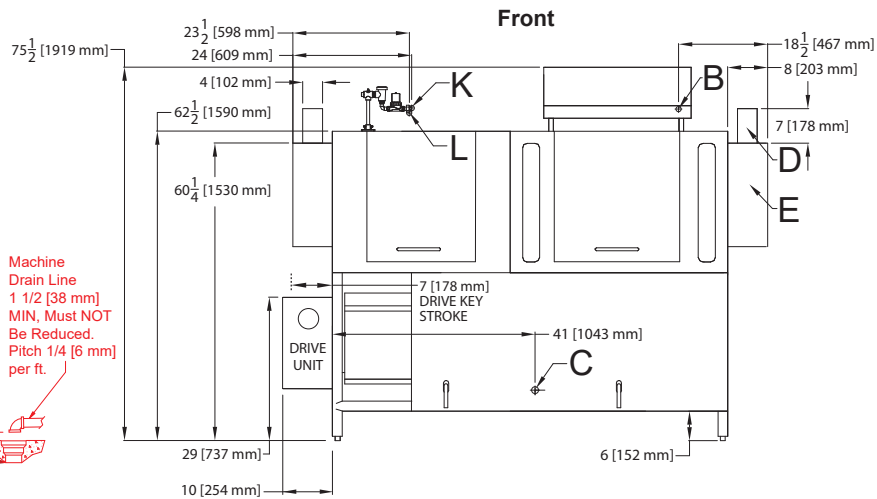
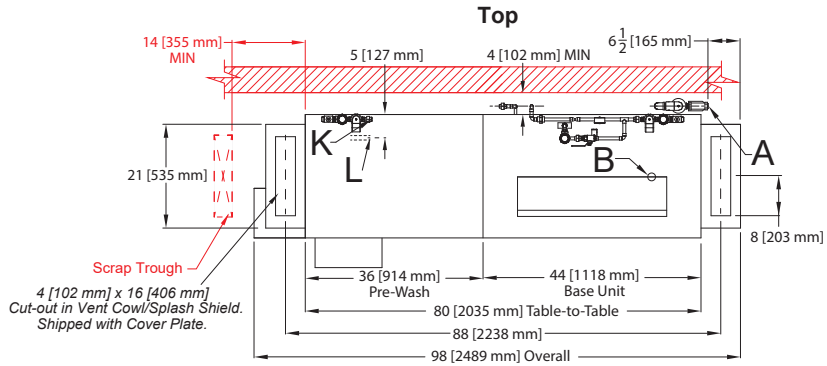

## Right-to-Left

### LEGEND

- A - Water Inlet  
(3/4" NPT, 110-140 °F MIN)
- B - Electrical Connection
- C - Drain Connection (1 1/2" NPT)
- D - Vent Collar - Optional
- E - Vent Cowl - Standard
- F - Water Inlet for Booster  
(3/4" NPT, 110-140 °F)
- G - Water Outlet to Machine  
(3/4" NPT, 180 °F)
- H - Gas Connection (3/4" NPT)
- J - Vent Pipe Connection (4" OD)
- K - Pre-wash Water Inlet  
(3/4" NPT, 110-140 °F)
- L - Cold Water Thermostat - Optional  
(3/4" NPT)

All dimensions from the floor can be increased 1" using the machine's adjustable feet.

Items in red are not supplied with the machine.

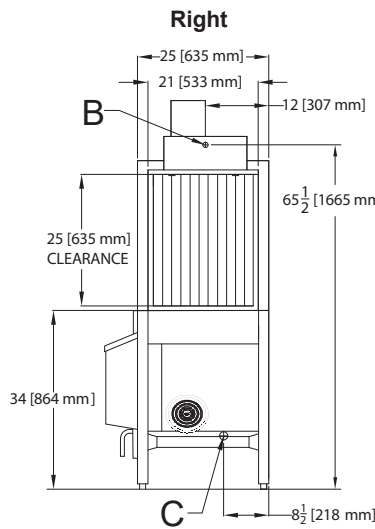
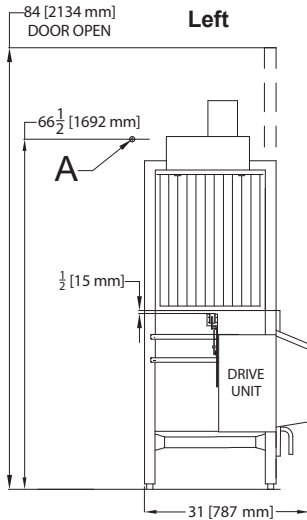
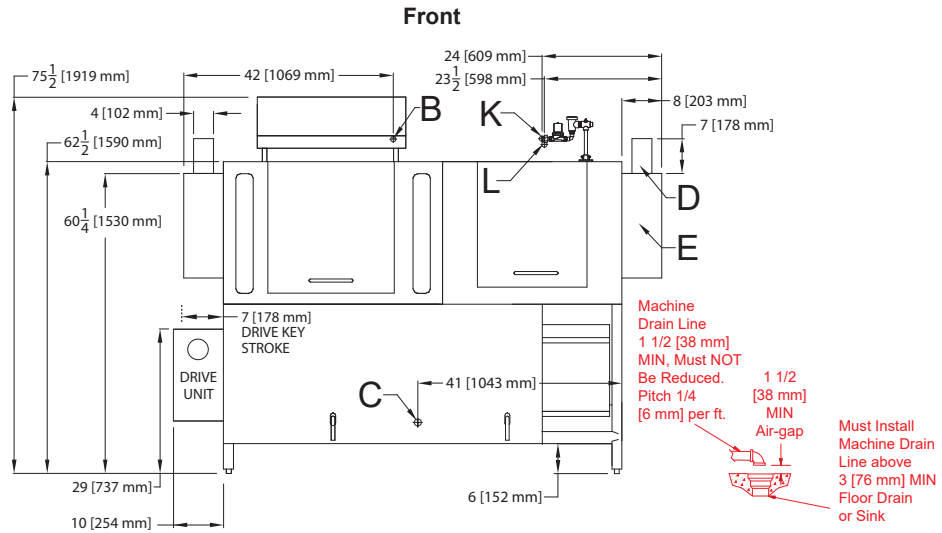
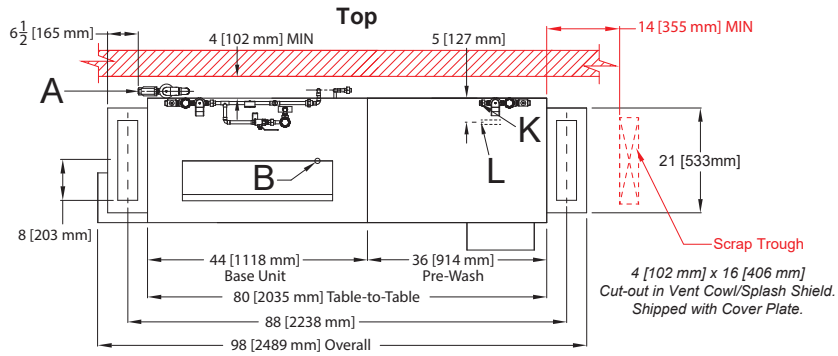

**Gas Booster**  
Gas Booster can be located anywhere, but must be 6 [154 mm] MIN from the machine.

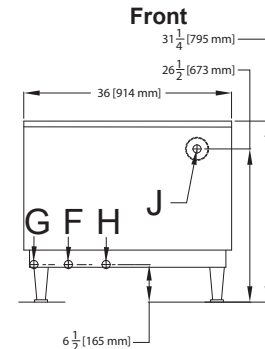
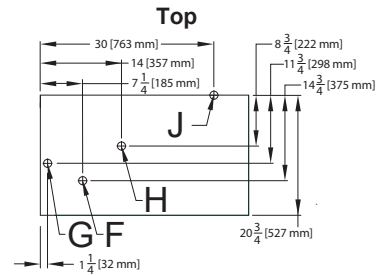

Left-to-Right

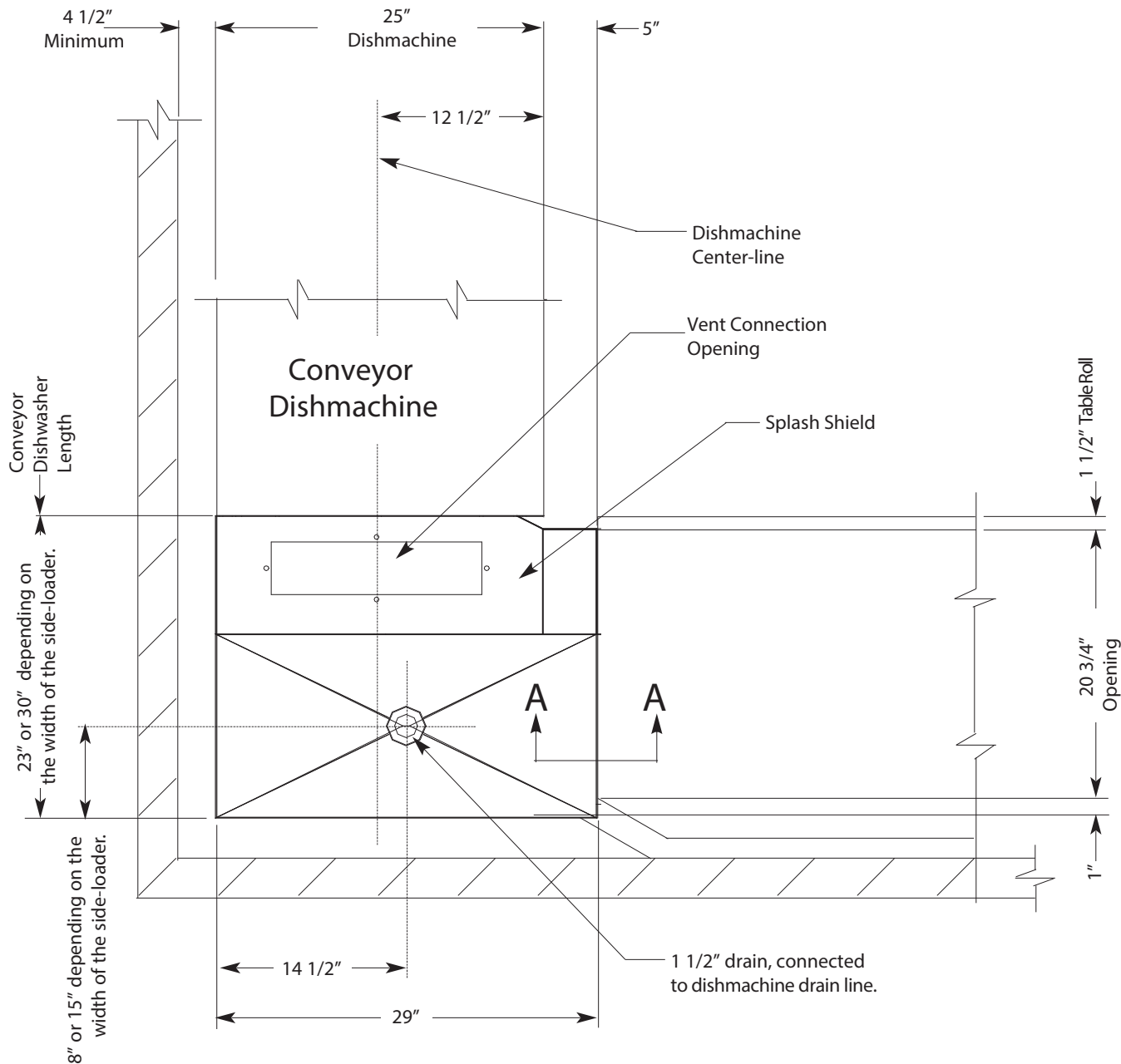

**Section A-A**

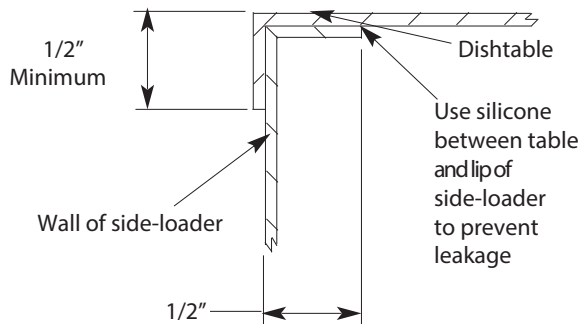



Right-to-Left

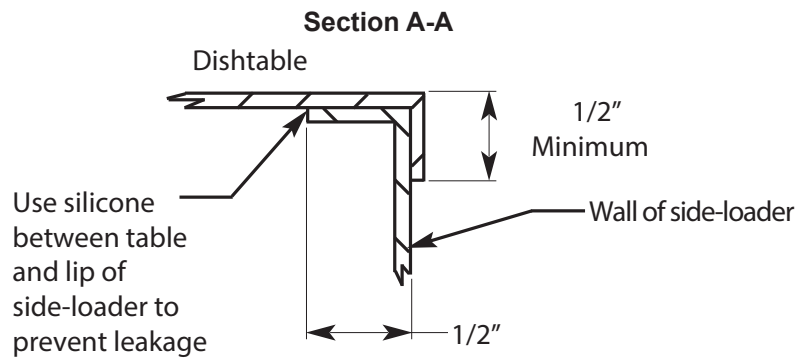
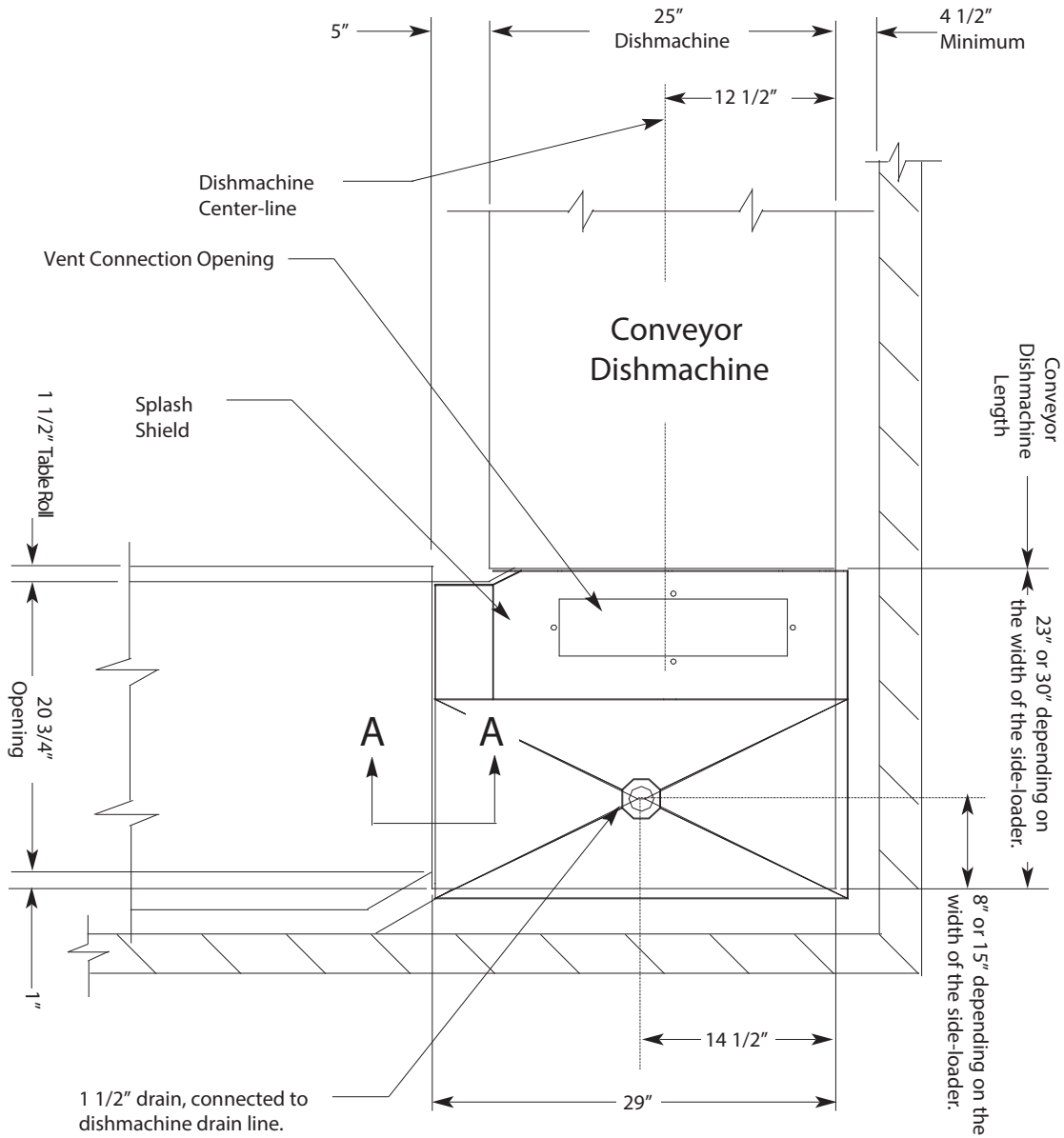

# SPECIFICATIONS

# SIDE-LOADER & TABLE INSTALL

## Side-loader Install

23" SIDE-LOADER DIMENSIONS		30" SIDE-LOADER DIMENSIONS	
MODEL	DIMENSIONS	MODEL	DIMENSIONS
AJ-44	75"	AJ-44	82"
AJ-66	97"	AJ-66	104"
AJ-80	111"	AJ-80	118"

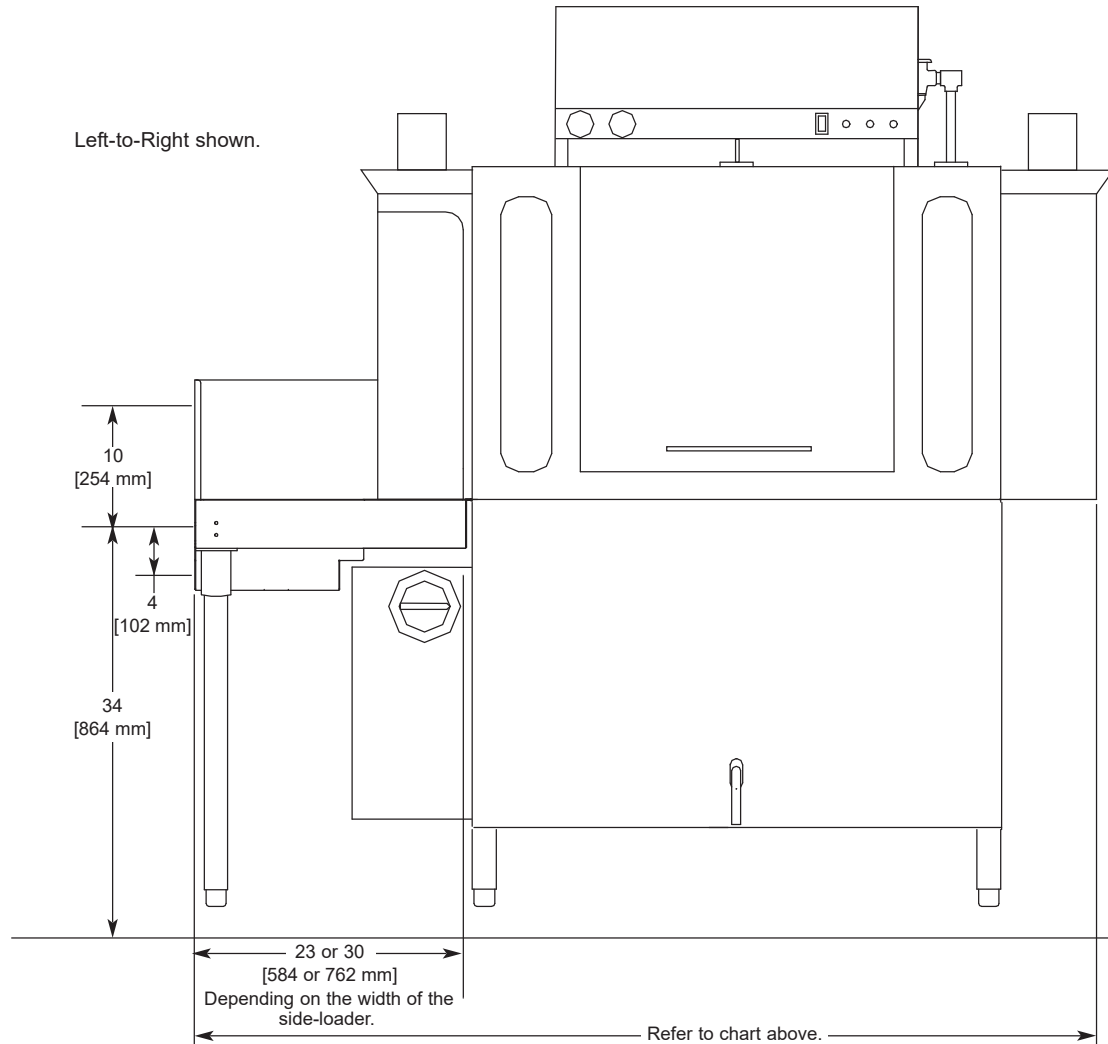

## Table Install

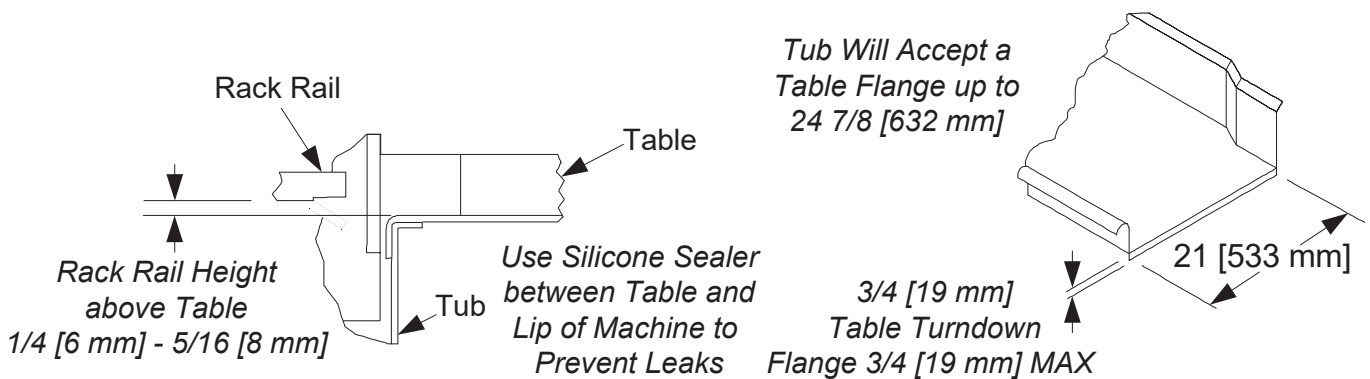

## OPERATING SPECIFICATIONS

### AJ-44/66/80

Racks per Hour	248
Dishes per Hour	6200
Glasses per Hour	8928

### Pre-wash

Tank Capacity (Gallons)	16
Pump Capacity, AJX-66 (GPM)	120
Pump Capacity, AJX-80 (GPM)	270

### Wash

Tank Capacity (Gallons)	15.4
Pump Capacity (GPM)	270

### Ventilation Requirements (CFM)

Input End	200
Output End	400
Total	600

### Conveyor Speed (FPM)

AJ-44/66	6.9
AJ-80	7.5

### Gallons per Rack

AJ-44/66/80	0.94
-------------	------

### Motor Characteristics

Drive Motor (HP)	1/4
Wash Motor (HP)	2
Pre-wash Motor, AJ-66 (HP)	1
Pre-wash Motor, AJ-80 (HP)	2

## WATER REQUIREMENTS

### AJ-44/66/80

Minimum Wash Temperature (°F/°C)	150/66
Minimum Power Rinse Temperature (°F/°C)	160/71
Minimum Rinse Temperature (°F/°C)	180/82
Pre-wash Temperature (°F/°C)	110–140/43–60
Flow Pressure (PSI)	20 ± 5
Flow Rate (GPM)	3.9
Water Line Size (NPT)	3/4"
Drain Line Size (NPT)	1 1/2"

### NOTICE



Always refer to the machine data plate for specific electrical and water requirements. The material provided on this page is for reference only and is subject to change without notice.



All electrical ratings provided in this manual are for reference only. Always refer to the machine data plate to get the exact electrical information for this machine. **All electrical work performed on machines should be done in accordance with applicable local, state, territorial, and national codes.** Work should only be performed by qualified electricians and authorized service agents.

Note that all electrical wiring used in the machine must be rated, at a minimum, for 212 °F (100 °C), and that only copper conductors must be used.

Where applicable, heating element amperage draws have been adjusted for the assumed input voltage. The manufacturer assumes incoming voltages will be either 208, 230, or 460 Volts. Some of the heating elements used in the machines are actually rated for other voltages, such as 240 or 480 Volts. Always verify the amperage draw of the machine in operation when sizing circuit protection.

The gas booster has its own electrical connection and requires a separate service. Amperage loads for machine are listed on the machine data plate. See manufacturer's documentation for amperage loads of gas booster.

### Available Electrical Characteristics:

- 208 V, 60 Hz, Single-phase
- 230 V, 60 Hz, Single-phase
- 208 V, 60 Hz, Three-phase
- 230 V, 60 Hz, Three-phase
- 380 V, 50 Hz, Three-phase
- 460 V, 60 Hz, Three-phase



*Local codes may require more stringent protection than what is displayed here and on the data plate. Always verify with your electrical service contractor that your circuit protection is adequate and meets all applicable national and local codes. Numbers in this manual are for reference and may change without notice.*

**NOTICE** On three-phase machines, imbalanced wild leg goes to L3. Also see the Motor Rotation section.

### AJ-44CGP

Volts	Phase	Freq	Wash Motor	Drive Motor	Recirculating Pump	Total Load	MCA	MOP
208	1	60 Hz	8.7 A	1.8 A	1.7 A	12.2 A	14.4 A	20 A
230	1	60 Hz	9.6 A	1.8 A	1.7 A	13.1 A	15.5 A	25 A
208	3	60 Hz	5.8 A	1.2 A	1.7 A	8.7 A	10.2 A	15 A
230	3	60 Hz	5.7 A	1.1 A	1.7 A	8.5 A	9.9 A	15 A
460	3	60 Hz	2.9 A	0.6 A	1.7 A	5.1 A	5.8 A	15 A

### AJ-66CGP

Volts	Phase	Freq	Wash Motor	Pre-wash Motor	Drive Motor	Recirculating Pump	Total Load	MCA	MOP
208	1	60 Hz	8.7 A	6.2 A	1.8 A	1.7 A	18.4 A	20.6 A	25 A
208	3	60 Hz	5.8 A	3.3 A	1.2 A	1.7 A	12.0 A	13.5 A	15 A
230	3	60 Hz	5.7 A	3.2 A	1.1 A	1.7 A	11.7 A	13.1 A	15 A
380	3	50 Hz	5.1 A	1.8 A	0.9 A	1.7 A	9.5 A	10.8 A	15 A
460	3	60 Hz	2.9 A	1.6 A	0.6 A	1.7 A	6.7 A	7.4 A	15 A

## INSPECTION

Before installing the machine, check the packaging and machine for damage. Damaged packaging indicates possible damage to the machine. If there is any type of damage to both the packaging and machine, **DO NOT THROW AWAY THE PACKAGING**. The machine has been inspected at the factory and is expected to arrive in new, undamaged condition. However, rough handling by carriers or others might result in damage to the machine while in transit. If this occurs, **DO NOT RETURN THE MACHINE TO THE MANUFACTURER**. Instead, contact the carrier and ask them to send a representative to the site to inspect the damage and complete an inspection report. You must contact the carrier and the dealer that sold you the machine within 48 hours of receiving the machine.

*Do not throw away the packaging if damage is evident!*

## UNPACKING

The machine should be unpacked and removed from the pallet before installing. Remove the wooden lift beams and their associated brackets after the machine has been positioned. Open the front door and remove all materials from inside. Once unpacked, verify there are no missing parts. If a part is missing, contact the manufacturer immediately.

## LEVELING

The machine is designed to operate while level. This is important to prevent any damage to the machine during operation and to ensure the best results. The machine comes equipped with adjustable bullet feet, which can be turned using a pair of pliers. Verify the machine is level from front-to-back and side-to-side before making any electrical or plumbing connections.

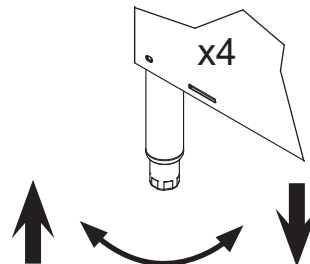

## FACILITY HOT WATER HEATER

The manufacturer does NOT endorse "Tankless On-demand" water heaters for use with their machines. The manufacturer DOES endorse, and highly recommends, the standard "Tank" style water heaters, sized to properly handle the water heating requirements of the facility.

## PLUMBING

*The plumber **MUST** flush the incoming water line!*

*A water hardness test **MUST** be performed.*

All plumbing connections must adhere to local, state, territorial, and national codes. The installing plumber is responsible for ensuring the incoming water lines are flushed of debris before connecting the machine. Chips and materials from cutting processes can become lodged in the solenoid valves and prevent them from opening or closing. Any valves that are found to be fouled or defective because of foreign matter left in the water line—and any subsequent water damage—are not the responsibility of the manufacturer.

If water hardness tests greater than 3 GPG, install the Scaltrol Water Treatment system (see the Plumbing Options page) into the water line before the machine's incoming water connection point. If water hardness tests 3 GPG or lower, install the water supply line directly to the machine's incoming water connection point. Iron in the water line can cause staining. A filter designed to remove iron from the water supply is highly recommended for supplies in excess of 0.1 ppm.

The machine uses a flow pressure of  $20 \pm 5$  PSI for the incoming water line. Do not confuse static pressure with flow pressure. Static pressure occurs when there is no flow and the valves are closed. Flow pressure occurs when water is running into the machine.

The water supply line must be 3/4" NPT minimum and must be able to provide water at the minimum temperature indicated on the machine data plate.

A shut-off valve (**not supplied**) should be installed to isolate the machine from the water system in the event service is required. An optional shock absorber (**not supplied**) should also be installed on the incoming water line (see the Plumbing Options page). This prevents water hammer (hydraulic shock) from causing damage to the equipment.



## DRAIN LINE

The drain for the machine is a gravity-discharge drain. All piping to the machine drain must be a minimum 1 1/2" NPT and must not be reduced. There must be a minimum 1 1/2" air-gap between the machine drain line and the floor drain or sink. The floor drain or sink must be a minimum 3" NPT. If a grease trap is required by code, it should have a flow capacity of 30 GPM. AJ-44 machines have one drain connection point and AJ-66/80 machines have two (connected and drained into one facility floor drain or sink).



**CAUTION!** An air-gap is required between the drain line and floor drain or sink.

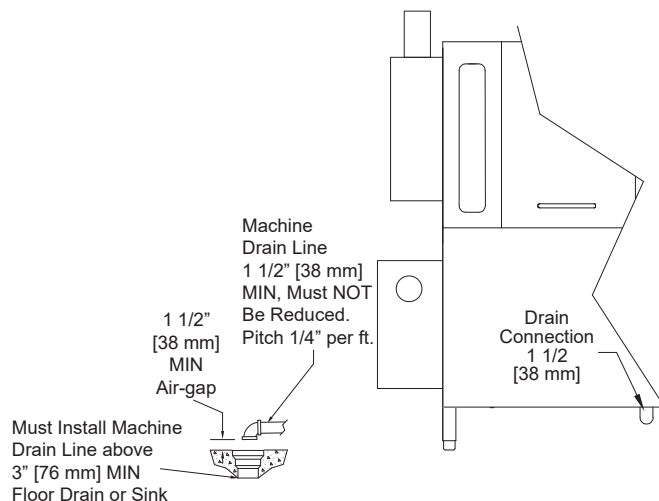

## ELECTRICAL POWER CONNECTIONS



**Disconnect electrical power at the breaker or disconnect switch and tagout in accordance with procedures and codes.**

All electrical connections must be made in accordance with applicable portions of local, state, territorial, and national codes.

Refer to the data plate for machine operating requirements, machine voltage, total amperage, and serial number.

1. Locate main power terminal blocks (for machine and gas booster) at the top of the machine.
2. Remove the top cover to access terminal blocks.
3. Route incoming power lines within conduit that will connect via fittings to the pre-punched holes in the back of the control box.
4. Install power and ground wires to lugs as indicated by the appropriate decals in the control box. Use copper conductors only. Use of an anti-oxidation agent is recommended on the power connections.

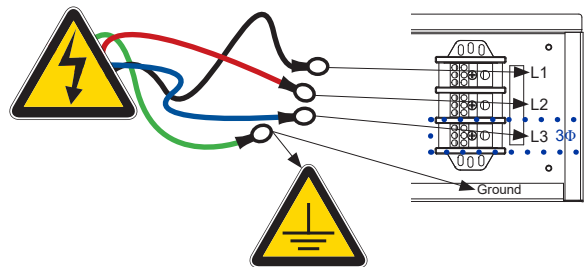

**NOTICE**  
Imbalanced wild leg goes to L3.

5. Tighten all connections.
6. Verify the incoming voltage matches the voltage indicated on the decal next to the incoming power pre-punched hole.



**NOTICE** *The machine has a separate power connection for gas boosters and the circuit protection requirements are different for each. Consult booster manufacturer for information.*

## MOTOR ROTATION

On 3-Phase machines only, correct pump motor rotation must be verified before the machine is operated. Failure to do so can result in damage to the machine and components.

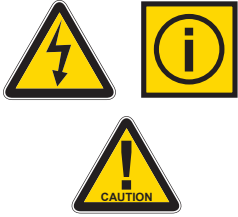

**CAUTION!** On 3-Phase machines only, correct pump motor rotation must be verified before operation!

1. Follow the Power Up section.

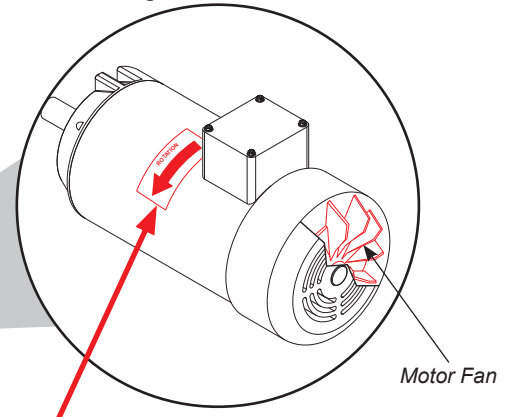
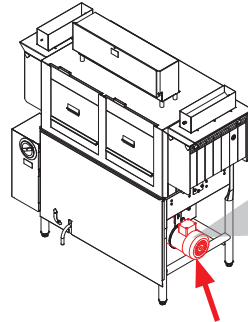

2. Locate the wash pump motor and identify the arrow decal which shows the correct motor rotation (if no decal is present, correct rotation is toward front of machine).
3. Flip AUTOMATIC/DELIME button to DELIME.
4. Flip ON/OFF button to ON.
5. Observe rotation of motor fan and quickly flip ON/OFF button to OFF.
6. If rotation is incorrect, disconnect electrical power and reverse the L1 and L2 connections at terminal block shown in the previous section.

## VENTILATION

The machine should be located with an adequate exhaust hood or ventilation system with provisions for venting. This is essential to permit efficient removal of the condensation exhaust. Ensure the exhaust system is acceptable in accordance with applicable codes and standards.

**NOTICE** Any damage caused by steam and/or moisture due to improper ventilation is NOT covered under the warranty.

Machine ventilation requirements:

- **Load End: 200 CFM**
- **Unload End: 400 CFM**

The exhaust system must be sized to handle this volume for the machine to operate properly.

## THERMOSTATS

The thermostats on this machine have been set at the factory and should only be adjusted by an authorized service agent.

## TABLE LIMIT SWITCH OPTION

There are two Table Limit Switch options available. Click on the instruction icons below for install guides.

### Striker Switch



### Whisker Switch





## CHEMICAL FEEDER EQUIPMENT



**WARNING!** Some chemicals used in dishwashing can cause chemical burns if they come in contact with skin. Wear protective gear when handling these chemicals. If any skin comes in contact with these chemicals, immediately follow the instructions provided with the chemicals for treatment.

This machine does not come with an integrated chemical supply/feeder system. For the machine to operate correctly, connect it to a third-party chemical dispenser (see Connection Points section) that meets the requirements of NSF Standard 29. Contact a chemical supplier about connecting a dispenser to the machine. Chemical dispensers must be set for the type and concentration of chemicals being used.

Detergent usage and water hardness are two factors that contribute greatly to how efficiently the machine will operate. Using the proper amount of detergent can be a source of substantial savings. A qualified water treatment specialist can explain what is needed to gain the maximum efficiency from detergent.

## CONNECTION POINTS

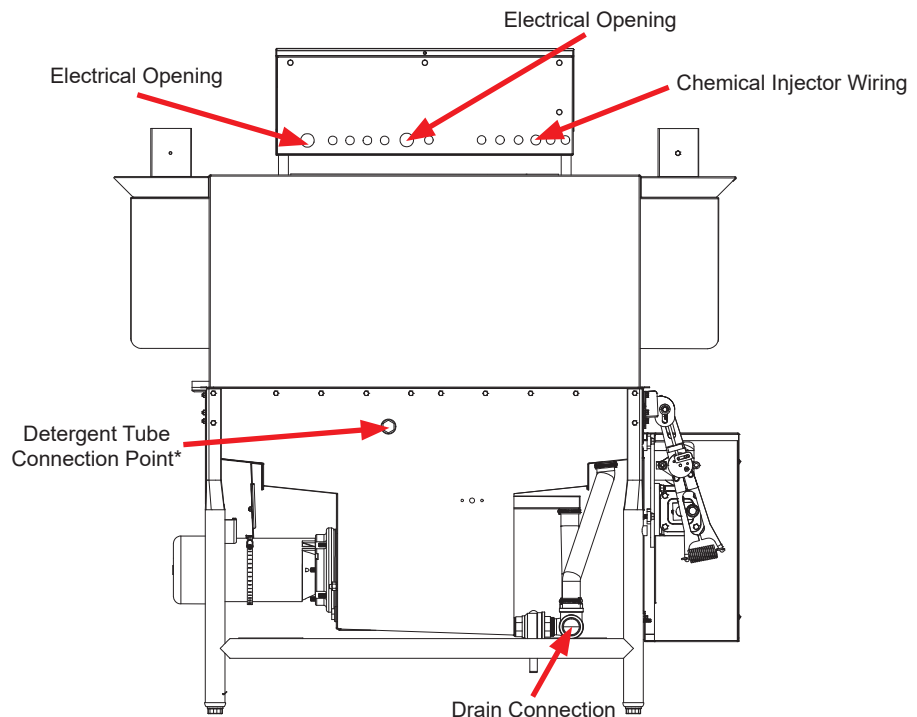
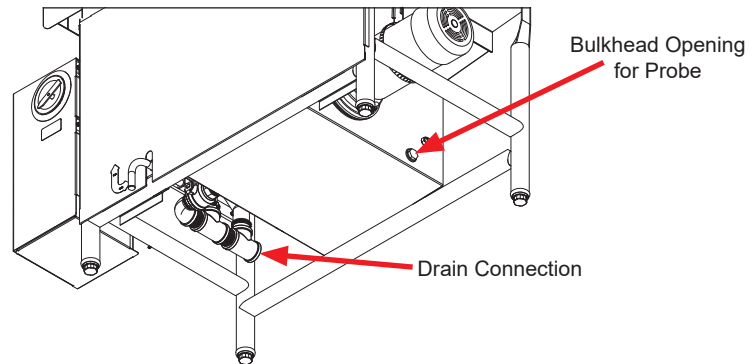

View of machine to the right is shown with plumbing removed for clarity.

\*See next page for rinse-aid tube connection.

**CONNECTION POINTS**

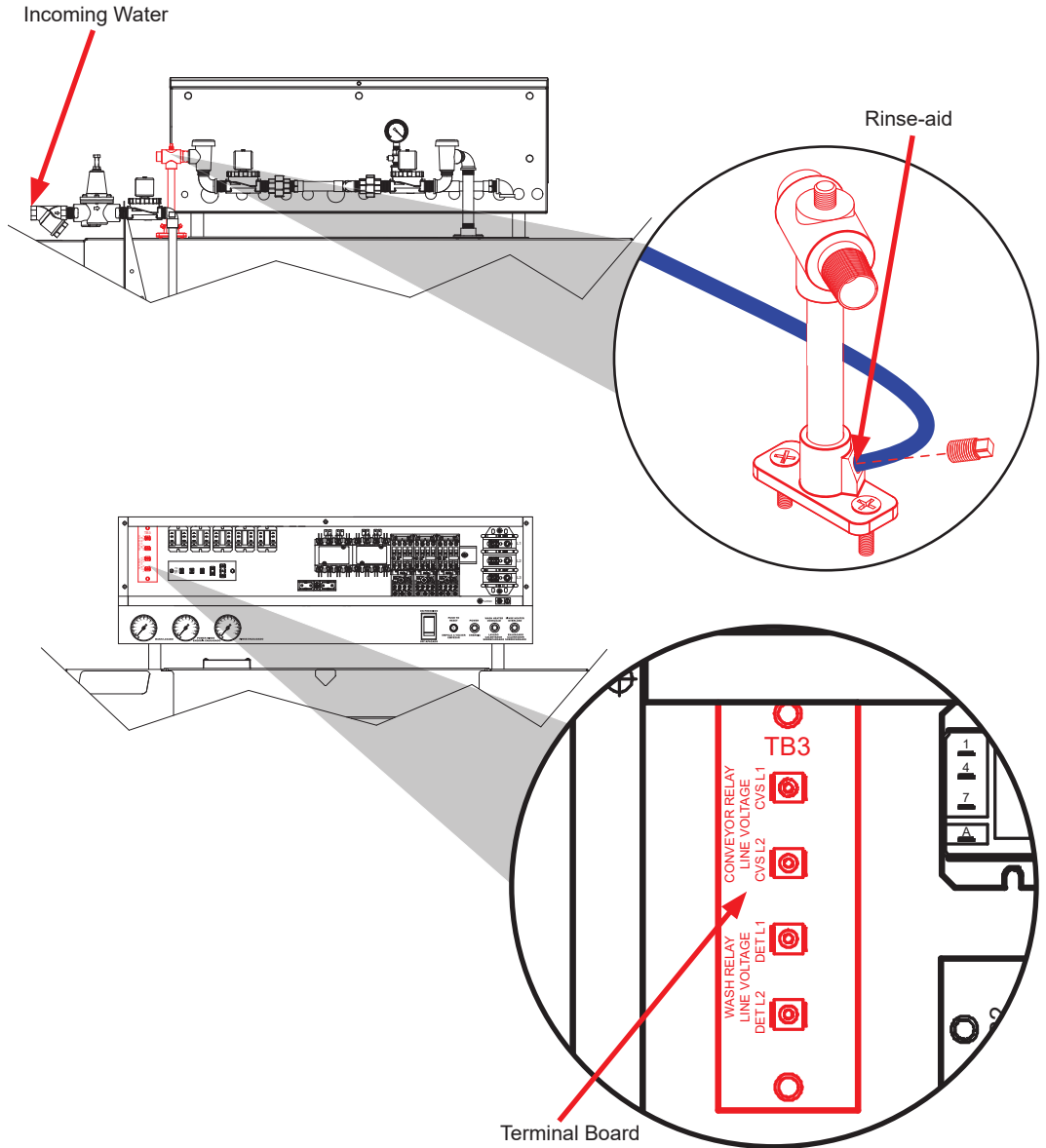

*Rinse-aid tube connection shown to the right.*

*Terminals marked "CVS" provide a voltage signal whenever the drive motor is operating.*

*Terminals marked "DET" provide a voltage signal whenever the wash motor is operating.*

*There is no dedicated connection for a rinse-aid dispenser on the machine.*

**EXHAUST FAN TIMER**

Click [here](#) for instructions on programming the exhaust fan timer. The instructions can also be accessed by navigating to them on our website.



Decals mark the curtain locations inside the machine, starting at the load end and ending at the unload end. The illustrations below (Left-to-Right machines shown, Right-to-Left are mirrored) indicate the curtain size to be placed on the curtain hooks provided. If any curtain components are missing, they **MUST** be obtained and installed before operation.

**CGP**

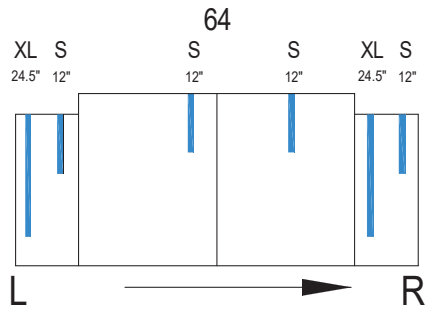

**86-100**

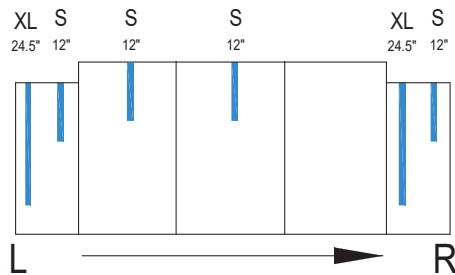

**Hooded Side-loader**

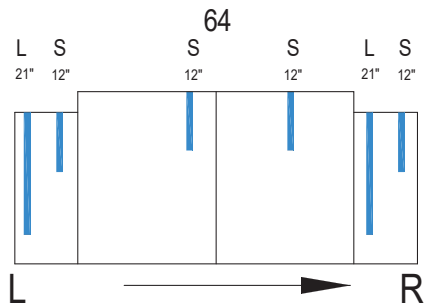

**86-100**

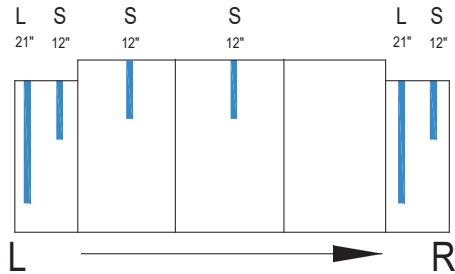

**NOTICE** See Curtains/Conveyor Switch page for part numbers.

The hosing connecting the gas booster to the machine must be customized during each installation. The appropriate 3/4" hosing, fittings, and gaskets are provided. Additional hosing can be ordered from the manufacturer, if necessary. Placing the gas booster more than 20 feet from the machine can affect performance.

1. Attach first barbed hose fitting to end of uncut hose and attach that fitting to appropriate connection on the machine.
2. Screw second barbed hose fitting to appropriate connection on the gas booster.
3. Run loose end of hose to corresponding connection on the gas booster, ensuring there are no sharp turns or kinks.
4. Cut hose even with yellow plastic stop on second barbed hose fitting.
5. Push cut end of hose onto second barbed hose fitting until it meets yellow plastic stop.

*A lubricant (e.g. petroleum jelly) can be used to aid in pushing hose onto fittings.*

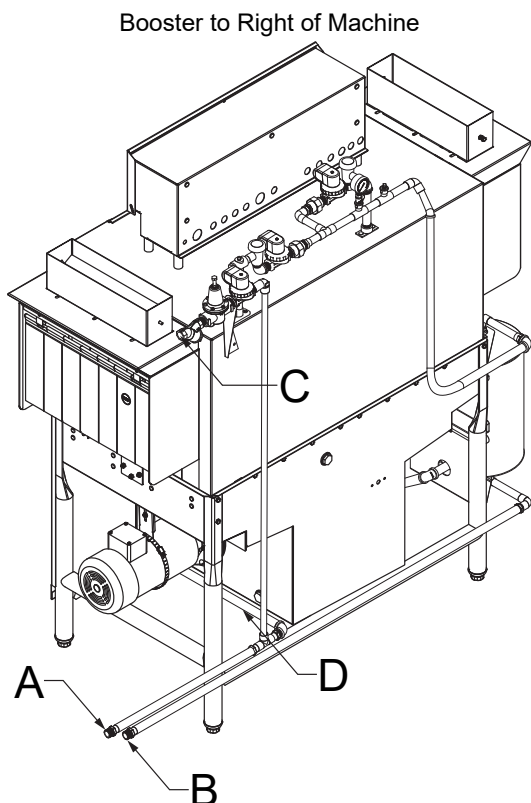
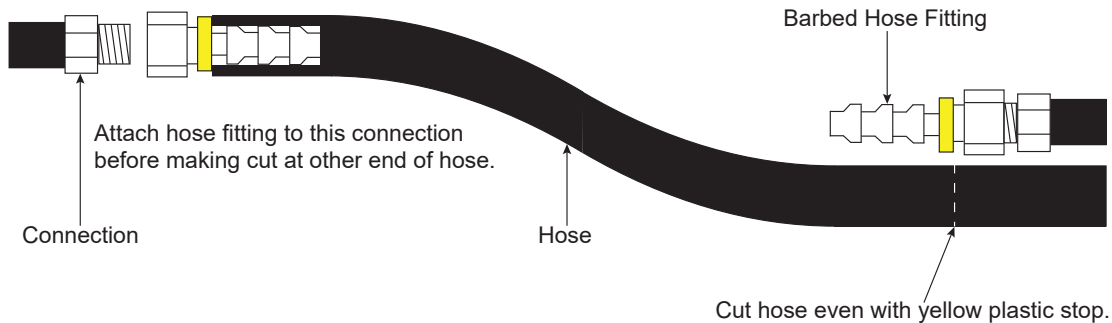

A - Connect to Inlet Water on Booster  
B - Connect to Outlet Water on Booster

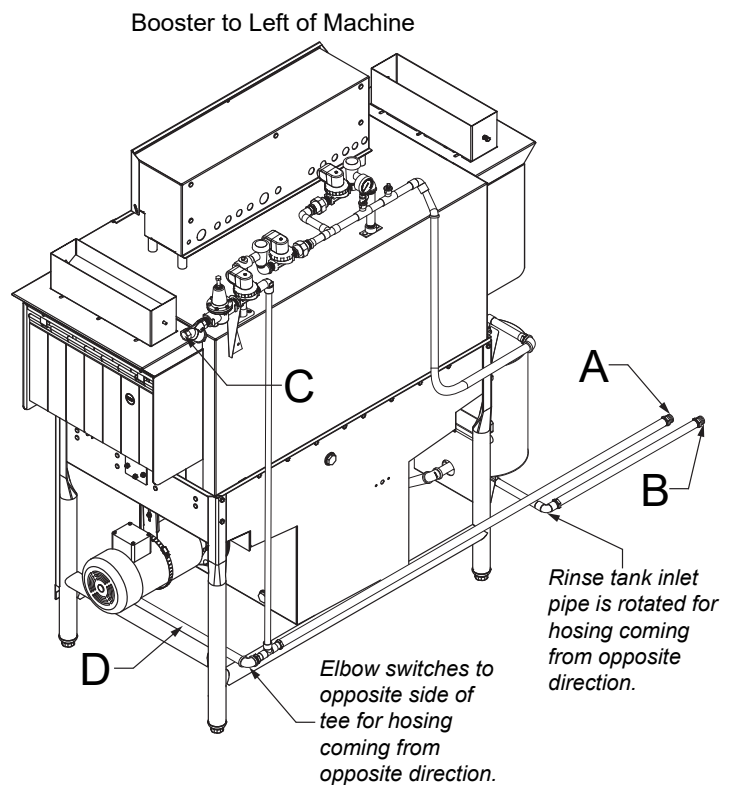

C - Machine Inlet Water  
D - Connect to Recirculating Pump

*L-R shown. R-L is mirrored.*

## PREPARATION Before operating the machine, verify the following:

1. Drain handle is turned to "CLOSE" position.

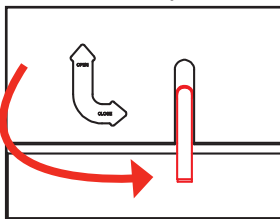

2. Strainers and pawl bar are installed and secure.

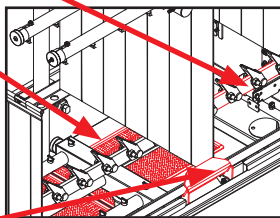

3. Actuator switches move with relative freedom and do not bind.

4. Curtains are installed correctly.

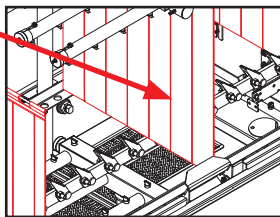

## POWER UP 1. Turn power on at the service breaker.

2. Press ON button on front of the machine to fill the machine and heat the water.

*For machines with pre-wash sections, ensure water is present in the pre-wash section before operating.*

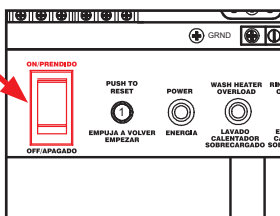

3. Allow wash tub to fill completely and wash water to reach operating temperature before continuing (an accurate rinse temperature will not display until machine is rinsing).

*Ensure gas is connected and flowing to the machine.*

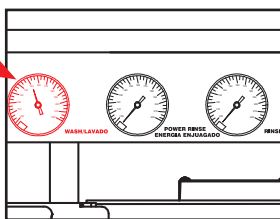

4. For Steam machines, ensure the steam service is connected and steam is flowing to the machine.

**FIRST RACK**

The first rack of ware placed in the machine will typically reduce the temperature of the wash tank, and might need to run through the machine again. This process might be necessary any time the machine has not been operated for an extended period of time, although this is dependent on the type of ware being used, its temperature, and the ambient temperature of the kitchen area. To ensure proper operation, always observe the temperatures of the wash and rinse when first starting the machine.

**WARE PREPARATION**

Proper preparation of ware is essential for the smooth, efficient operation of this machine.

Any ware placed in the machine should have all solid food waste and scraps removed. Ware should also be sprayed-down before entering the machine.

Place cups and glasses upside-down in racks so they do not hold water during the cycle. Presoak flatware in warm water to assist in removing food. Load plates and saucers in the same direction, with the food surface facing the unload end of the machine.

**WASHING A RACK OF WARE**

This machine is designed to wash ware that is placed in a rack. Materials should not be placed in the machine unless they are properly secured in a dish rack.

To start the cycle, gently push the rack into the machine on the load end. Once the wash actuator has moved sufficiently, the machine will automatically begin to convey the dish rack through the machine. The entire cycle is automatic.

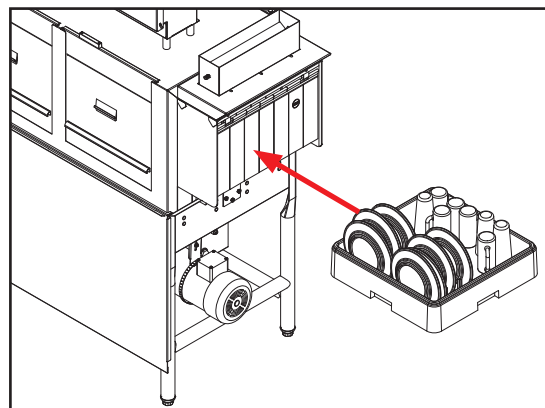

*R-L machine shown.*

**OPERATIONAL INSPECTION**

*For machines with pre-wash sections, also inspect the pre-wash strainer and wash arm nozzles.*

Operators should periodically review the following items while the machine is operating. These items are important for operating the machine efficiently.

- Review wash and rinse temperatures and compare to the minimums on the data plate.
- Verify strainers are not becoming clogged. Keep these free of soil and debris for much better flow of water through the machine and to prevent re-deposit issues.
- Water pressure: The machine is designed to run at  $20 \pm 5$  PSI; if it is any lower there will not be enough rinse water to properly remove detergent from the ware.
- Wash and rinse arm nozzles should be free of debris. Open nozzles are essential to the operation of the machine.

**SHUTDOWN** To shut the machine down, press the OFF button on the front of the machine. To drain the machine, move the drain handle to the OPEN position. Shut down gas booster according to its manufacturer's instructions.

**CLEANING** Clean the machine at least once every 24 hours or at the end of the day. Cleaning removes soil and debris that might become trapped in nozzles or deposited onto ware.

1. Remove all strainers and use a hand-scraper to scrape foodsoil into trash.

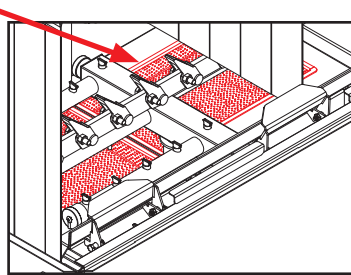

*For machines with pre-wash sections, also remove and clean the pre-wash strainer.*

2. Remove float switch cover and clean it and strainers with the pre-rinse hose.

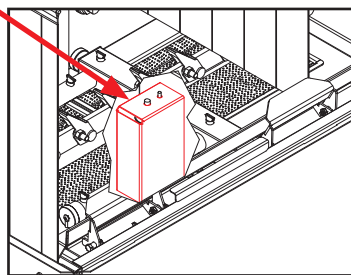

3. Rinse float switch off and rinse the tank out. Inspect tank for debris.

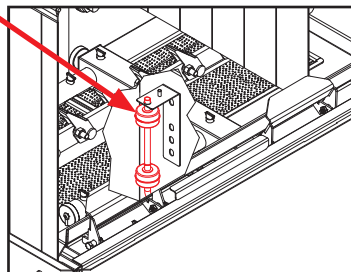

4. Remove curtains, scrub with mild detergent and brush, and allow to air-dry.

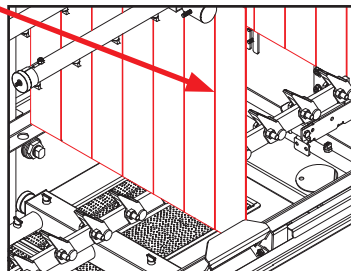

*For machines with pre-wash sections, also remove and clean the pre-wash curtains.*

- CLEANING** 5. As needed, clean the wash and rinse arms:
- a. Remove wash arm manifolds.

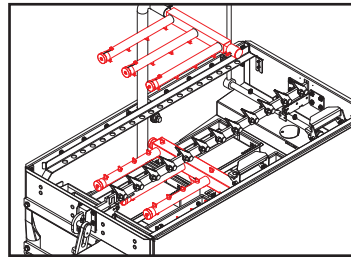

*For machines with pre-wash sections, also remove and clean the pre-wash arm.*

- b. Remove end-caps from arms and manifolds.

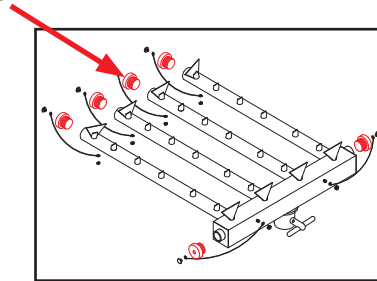

- c. Clean nozzles with a brush. Also clean rinse assembly nozzles.

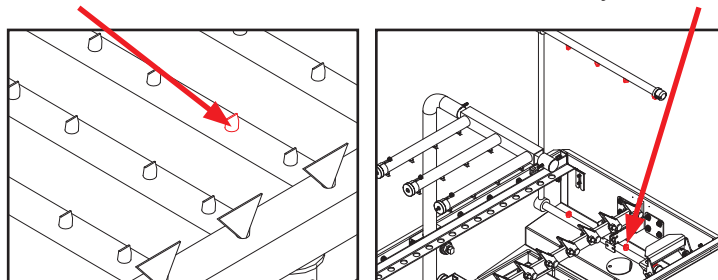

- d. Use a small wire or toothpick to remove remaining debris or lime deposits from nozzles.
- e. Flush arms with water.

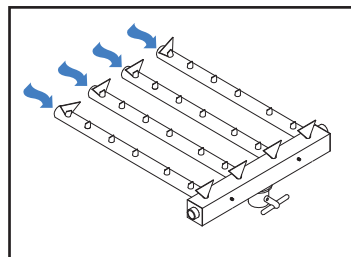

- f. Replace end-caps and ensure they have been tightened.
- g. Replace wash arm manifolds.

**Do NOT clean the machine with any type of metallic scrubbing sponge!**

The outside of the machine should be cleaned with a standard countertop or general cleaner. Do not attempt to clean inside any compartments, boxes, or chambers that are secured with a cover. These normally contain live electrical components.



## DELIMING

1. Disconnect/turn off chemical feeder equipment.
2. Turn the machine on.

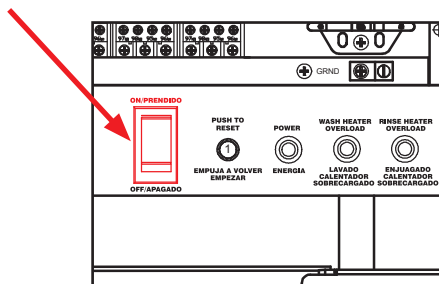

3. Add deliming solution according to chemical supplier's instructions.
4. Close door.
5. Flip AUTOMATIC/DELIME switch to DELIME.
6. Run the machine period of time recommended by chemical supplier.
7. Wait five minutes, then inspect inside of the machine. If the machine is not delimed, run again.
8. Flip AUTOMATIC/DELIME switch to AUTOMATIC.

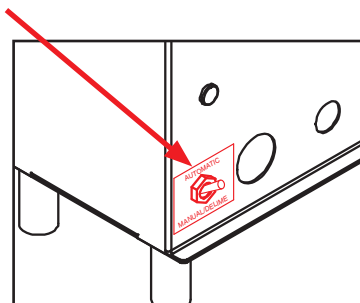

9. Run an empty rack through the machine twice.
10. Drain and re-fill the machine.
11. Reconnect/turn on chemical feeder equipment.



**CAUTION!** *This equipment is not recommended for use with deionized water or other aggressive fluids. Use of deionized water or other aggressive fluids will result in corrosion and failure of materials and components. Use of deionized water or other aggressive fluids will void the manufacturer's warranty.*

**PREVENTATIVE MAINTENANCE**

The manufacturer highly recommends that any maintenance and repairs not specifically discussed in this manual be performed only by **QUALIFIED SERVICE PERSONNEL**. Performing maintenance on your machine may void your warranty, lead to larger problems, or even cause harm to the operator. So if you have a question or concern, do not hesitate to contact a **QUALIFIED SERVICE AGENCY**.

By following the operating and cleaning instructions in this manual, you should get the most efficient results from your machine. As a reminder, here are some steps to ensure the machine is being used the way it was designed to work:



1. Ensure water temperatures match those listed on the machine data plate. There can be a variety of reasons why the water temperature could be too low.
2. Ensure all strainers are clean and in place laying flat before operating the machine. When cleaning out strainers, do NOT beat them on waste cans. Wipe-out strainers with a rag and rinse under a faucet if necessary. Use a toothpick to dislodge any stubborn debris.
3. Ensure all wash and rinse arms are secure in the machine before operating.
4. Ensure drains are closed before operating.
5. Remove as much soil from dishes by hand as possible before loading into racks.
6. Do not overfill racks.
7. Ensure glasses are placed upside-down in the rack.
8. Ensure all chemicals being injected into machine have been verified at the correct concentrations.
9. Clean the machine every 24 hours or at the end of every workday per the instructions in this manual.
10. Follow all safety procedures, whether listed in this manual or put forth by local, state, or national codes/regulations.

**TORQUE SETTINGS**

When replacing components in the control box or heater box, refer to the table below for the torque specs:

ITEM	TORQUE SPEC
Relays	16 in/lbs
Heater Contactor	35 in/lbs
Heater Nuts	16 in/lbs
Terminal Block	50 in/lbs

**DRIVE GEAR  
REDUCER  
LUBRICATION**

The maintenance procedures detailed here are manufacturer's instructions for the brand of gear reducer that is installed on the machines covered in this manual.

Ambient Temperature	-30 to 15°F	16 to 50°F	51 to 95°F	51 to 95°F	96 to 131°F	96 to 131°F
Final Stage Worm Speed*	up to 2000 FPM	up to 2000 FPM	up to 450 FPM	above 450 FPM	up to 450 FPM	above 450 FPM
ISO Viscosity Grade	220	460	680	460	680	460*
AGMA Lubricant No.	5S**	#7 Compounded***	#8 Compounded***	#7 Compounded***	8 S**	7S**

Mobil	SHC 630	600W Super Cylinder	Extra Hecla Super	600W Super Cylinder	SHC 636	SHC 634
American Lubricants	SHC-90W	AGMA #7 Gear Oil	AGMA #8 Gear Oil	AGMA #7 Gear Oil	N/A	N/A
Castrol	Tribol 800/220	Tribol 1105-7C	Tribol 1105-8C	Tribol 1105-7C	Tribol 800/680	Tribol 800/460
Chevron	Tegra 220	Cylinder Oil W460	Cylinder Oil W680	Cylinder Oil W460	Tegra 680	Tegra 460
Conoco	Syncon R & O 220	Inca Oil 460	Inca Oil 680	Inca Oil 460	N/A	Syncon R & O 460
Exxon (Esso)	Teresstic SHP 220	Spartan EP 460	Spartan EP 680	Spartan EP 460	Teresstic SHP 680	Teresstic SHP 460
Fiske Brothers	SPO-MG	SPO-277	SPO-288	SPO-277	N/A	N/A
Shell	Omala RL 220	Valvata J 460	Valvata J 680	Valvata J 460	Omala RL 680	Omala RL 460
Texaco	Pinnacle 220	Vanguard 460	Vanguard 680	Vanguard 460	Pinnacle 680	Pinnacle 460

\*The sliding velocity in feet per minute (FPM) for standard ratios is determined by multiplying the speed of the worm in RPM by the factor from the following table. For selecting the proper lubricant, use the speed of the worm in the final stage (input RPM divided by the first stage ratio).

\*\*Synthetic oil.

\*\*\*3% to 10% fatty or synthetic oils or mild EP additives.

Lubricant selections are provided by the lubricant manufacturer based on AGMA recommended viscosity grades.

Viscosity grades are based on Lubrication Standard ANSI/AGMA 9005-D94.

**Nominal Ratio**

Size	5	7.5	10	15	20	25	30	40	50	60	80	100
920	0.347	0.263	0.225	0.216	0.202	0.191	0.215	0.200	0.188	0.182	0.164	0.161

**Factory filling** - Speed reducers are filled with oil at the factory to the proper level for the standard mounting position it will be found on the machine. The oil level should be checked and adjusted (if necessary) before operation, using the oil level plug provided and while the machine is oriented in its operating position.

**Ambient temperature** - If the operating ambient temperature is other than 51 - 95 °F, refer to the lubrication chart and refill the machine with the correct grade based on actual ambient temperature and operating speed. See "Oil changing" below for additional information.

**Oil changing** - When changing the oil for any reason, it should be remembered that oils of various types might not be compatible. Therefore, when changing to a different oil, it is recommended that the housing be completely drained and thoroughly flushed with a light flushing oil before refilling with the appropriate lubricant. The oil level should be rechecked

## DRIVE GEAR REDUCER LUBRICATION

after a short period of operation and adjusted, if necessary. When changing double-reduction models, each housing should be drained and filled independently, even though there could be a common level.

**Initial oil change** - The new oil in a speed reducer should be changed at the end of 250 hours of operation. This is equivalent to 30 days of operation for eight hours per day; 15 days of operation for 16 hours per day, or 10 days of operation for 24 hours per day.

**Subsequent oil changes** - Under normal conditions, after the initial oil change, the oil should be changed after every 2500 hours of operation, or every six months, whichever comes first. Under severe conditions (rapid temperature changes, moist, dirty, or corrosive environment) it could be necessary to change the oil at intervals of one to three months. Periodic examination of oil samples taken from the machine will help establish the appropriate interval.

**Synthetic oils** - Synthetic lubricants can be advantageous over mineral oils in that they generally are more stable, have a much longer life, and operate over a wider temperature range. These oils are appropriate for any application but are especially useful when machines are subjected to low start-up temperatures or high operating temperatures. However, continuous operation above 225 °F may cause damage to seals or other components. It is recommended that the initial oil be changed or filtered after the first 1500 hours of operation to remove metal particles that accumulate during break-in. Subsequent oil changes should be made after 5000 hours operation if machines are operating in a clean environment. This can be extended to 10,000 hours if using new reformulated Mobil SHC lubricants (orange in color) and the lubricant remains free of contamination over this period. See comments under "Subsequent oil changes" for discussion of severe ambient conditions.

**Long-term storage or infrequent operation** - If a speed reducer is to stand idle for an extended period of time, either before installation or during use, it is recommended that the machine be filled completely with oil to protect interior parts from rust and corrosion due to internal condensation. Be sure to drain the oil to the proper level before placing the speed reducer in service.

**Grease fittings** - Some machines are equipped with grease fittings to lubricate bearings not adequately lubricated by the oil splash. These fittings must be lubricated every three to six months depending on operating conditions. Bearing greases must be compatible with the type of gear lubricant being used (e.g. mineral, synthetic, food grade, etc.). For mineral oils, use a high-quality lithium base NLGOI #2 bearing grease. For synthetic oils, use a synthetic bearing grease such as Mobil Synthetic Universal grease, Mobilith SHC 100 or a suitable equivalent. For food-grade lubricants, use Chevron FM grease, NGLI 2, or equivalent.

**Low input speeds (under 1600 RPM)** - When input speeds are less than 1600 RPM, grease fittings will be required to lubricate any bearings not partially covered by the normal oil level.

**Oil temperature** - Speed reducers in normal operation can generate temperatures up to 200 °F depending on the type of reducer and the severity of the application (loading, duration of service, ambient temperatures). Excessive oil temperatures could be the result of several factors including overloading, overfilling, underfilling, or inadequate cooling.



**WARNING:** Inspection, testing, and repair of electrical equipment should only be performed by a qualified service technician. Many of the tests require that the machine have power to it and live electrical components be exposed. **USE EXTREME CAUTION WHEN TESTING THE MACHINE.**

OBSERVATION	POSSIBLE CAUSE	REMEDY
Nothing on machine operates. The power switch is ON and the power indicator light is OFF.	<ol style="list-style-type: none"> <li>1. Machine is not wired correctly to incoming power source.</li> <li>2. Machine circuit breaker is tripped.</li> <li>3. Service breaker is tripped.</li> </ol>	<ol style="list-style-type: none"> <li>1. Have an electrician verify wiring.</li> <li>2. Reset the circuit breaker. If it trips again, contact an electrician to verify the machine amp draw.</li> <li>3. Reset the service breaker. If it trips again, contact an electrician to verify the machine amp draw.</li> </ol>
Machine will not fill. The power switch is ON and the power indicator light is ON.	<ol style="list-style-type: none"> <li>1. No water supplied to machine.</li> <li>2. Machine doors are not closed.</li> <li>3. Incoming water solenoid valve damaged/faulty.</li> <li>4. Tank floats faulty.</li> </ol>	<ol style="list-style-type: none"> <li>1. Verify water lines have been connected to the machine.</li> <li>2. Close doors completely.</li> <li>3. Verify the valve is operating. If not, replace.</li> <li>4. Verify the wiring of the floats. Verify that no debris is jamming the floats. Replace if necessary.</li> </ol>
Machine fills, but fill is weak.	<ol style="list-style-type: none"> <li>1. Low incoming water pressure.</li> <li>2. Incoming water solenoid is clogged.</li> </ol>	<ol style="list-style-type: none"> <li>1. Verify incoming water pressure during fill is 20 ± 5 PSI.</li> <li>2. Verify debris is not trapped in valve. If so, remove debris.</li> </ol>
Low wash tank temperature.	<ol style="list-style-type: none"> <li>1. Low incoming water temperature.</li> <li>2. Heater not energizing.</li> <li>3. Low incoming voltage.</li> </ol>	<ol style="list-style-type: none"> <li>1. Verify the incoming water temperature matches the data plate.</li> <li>2. Verify the wash tank heater is operating. If not, replace.</li> <li>3. Have an electrician verify incoming power is the same as indicated on the data plate.</li> </ol>
Low wash arm pressure, poor spray pattern.	<ol style="list-style-type: none"> <li>1. Clogged wash arm nozzles.</li> <li>2. Clogged wash tank or wash pump strainers.</li> <li>3. Worn wash pump impeller.</li> </ol>	<ol style="list-style-type: none"> <li>1. Verify nozzles are not clogged with debris. If so, remove debris.</li> <li>2. Clean out strainers if necessary.</li> <li>3. Verify status of impeller and replace if necessary.</li> </ol>
Inadequate rinse.	<ol style="list-style-type: none"> <li>1. Low incoming water pressure.</li> <li>2. Incoming water solenoid is clogged.</li> </ol>	<ol style="list-style-type: none"> <li>1. Verify incoming water pressure during fill is 20 ± 5 PSI.</li> <li>2. Verify debris is not trapped in valve. If so, remove debris.</li> </ol>
Pawl bar moves with no load, but does not move when loaded.	<ol style="list-style-type: none"> <li>1. Clutch on drive assembly is out of adjustment.</li> </ol>	<ol style="list-style-type: none"> <li>1. Adjust as required.</li> </ol>



**WARNING:** Inspection, testing, and repair of electrical equipment should only be performed by a qualified service technician. Many of the tests require that the machine have power to it and live electrical components be exposed. **USE EXTREME CAUTION WHEN TESTING THE MACHINE.**

OBSERVATION	POSSIBLE CAUSE	REMEDY
Pawl bar does not move.	<ol style="list-style-type: none"> <li>Failed or broken overload spring.</li> <li>No power to the drive motor or failed drive motor.</li> <li>Pawl bar not properly installed.</li> </ol>	<ol style="list-style-type: none"> <li>Replace spring if necessary.</li> <li>Verify power and wiring connections to the motor. If necessary, replace the motor.</li> <li>Verify the pawl bar is installed correctly.</li> </ol>
Racks go through the machine, but results are poor.	<ol style="list-style-type: none"> <li>Incorrect quantity of detergent for the water volume.</li> <li>Clogged strainers/scrap basket.</li> <li>Ware not being properly pre-scraped.</li> <li>Wash or rinse arms missing end-caps.</li> <li>Low tank heat.</li> <li>Inadequate rinse.</li> <li>Incorrect voltage coming to the machine.</li> <li>Wash pump cavitation due to low water level.</li> </ol>	<ol style="list-style-type: none"> <li>Adjust detergent to appropriate level.</li> <li>Clean out strainers and scrap basket.</li> <li>Review Ware Preparation section.</li> <li>Verify and replace as required.</li> <li>See previous page.</li> <li>See previous page.</li> <li>Verify the voltage matches that on the machine data plate.</li> <li>Verify the drains are shut and the water level is correct.</li> </ol>
Spotting of silverware, glasses, and dishes.	<ol style="list-style-type: none"> <li>Incorrect final rinse temperature.</li> <li>Clogged wash and/or rinse nozzles and arms.</li> <li>Excessively hard water.</li> <li>Loss of water pressure due to clogged/obstructed wash pump.</li> <li>Ware not being properly pre-scraped.</li> <li>Incorrect detergent/chemical concentrations.</li> </ol>	<ol style="list-style-type: none"> <li>Verify the rinse water temperature matches the data plate.</li> <li>Remove the arms and verify they and their nozzles are free of debris.</li> <li>Install a water softener.</li> <li>Turn the power off to the machine at the source. Drain the wash tank of water and verify the pump intake is free of debris.</li> <li>Review the Ware Preparation section.</li> <li>Verify the detergent/chemical concentrations are correct for the associated water volume.</li> </ol>

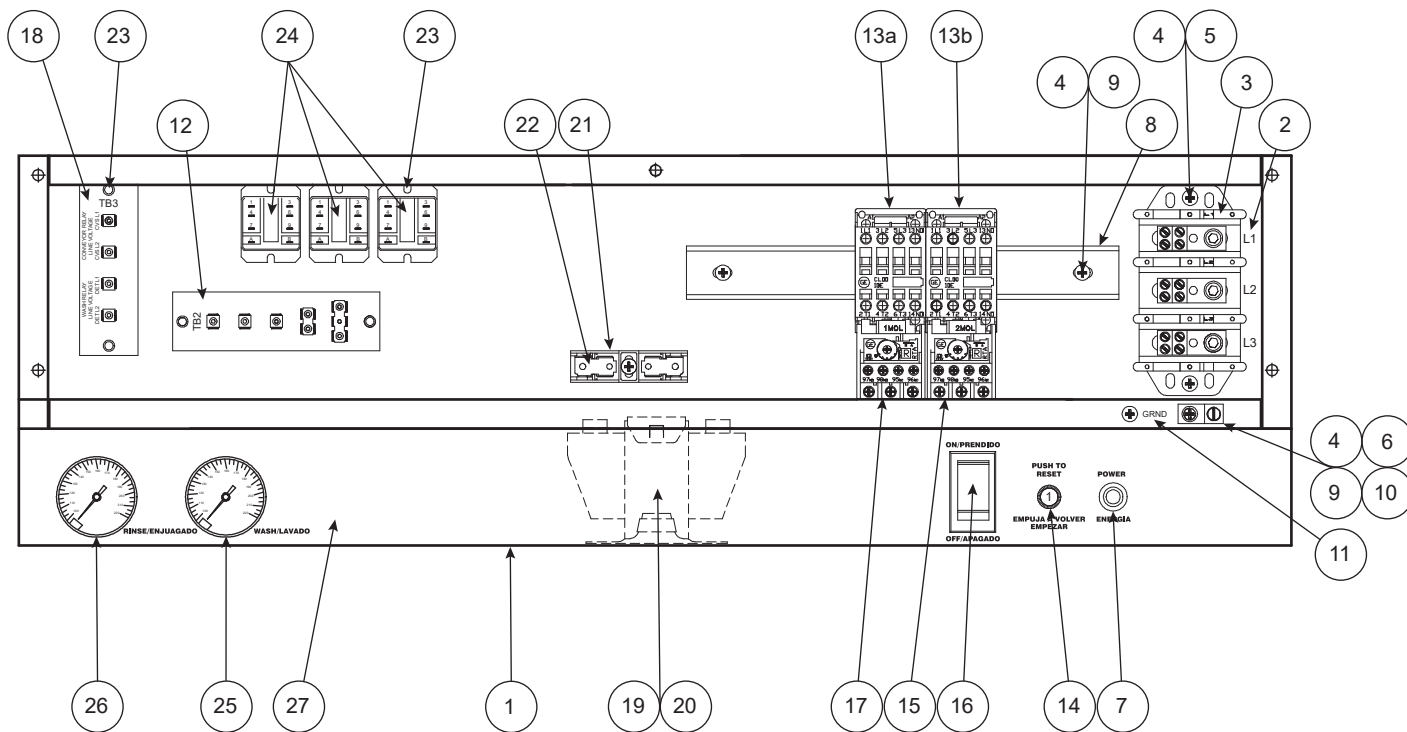

ITEM	QTY	DESCRIPTION	PART NUMBER
1	1	Electrical Box	05700-041-88-50
2	1	Decal, L1-L2-L3	09905-004-37-05
3	1	Terminal Block	05940-011-48-27
4	6	Lockwasher, #10	05311-273-02-00
5	2	Screw, 10-32 x 3/4" Phillips Trusshead	05305-011-62-17
6	1	Wire Lug, 2 AWG to 14 AWG	05940-200-76-00
7	1	Light, Red (Power)	05945-111-44-45
8	1	Din Rail	05700-021-72-75
9	3	Screw, 10-32 x 1/2" Phillips Trusshead	05305-011-39-36
10	1	Washer, Flat, 1/4"	05311-174-01-00
11	1	Decal, Ground	09905-011-86-86
12	1	Terminal Board	05940-002-78-97

ITEM	QTY	DESCRIPTION	PART NUMBER
13a	1	Drive Motor Contactor	05945-111-68-38
13b	1	Wash Pump Motor Contactor	05945-111-68-38
14	1	Circuit Breaker (208-230 V, 60 Hz Models Only)	05925-011-68-34
15	1	Wash Pump Motor Overload	See Motor Overloads page.
16	1	Switch, ON/FILL - OFF/DRAIN	05930-011-49-55
17	1	Drive Motor Overload	See Motor Overloads page.
18	1	Terminal Board	05940-021-89-41
19	1	Transformer	05950-002-46-10
20	2	Locknut, 10-24 with Nylon Insert	05310-373-01-00
21	1	Fuse Holder (460 V Only)	05920-011-72-89
22	1	Fuse (460 V Only)	05920-011-72-88
23	10	Screw, 6-32 x 3/8" Phillips Trusshead	05305-171-02-00
24	3	Control Relay, 2-pole	05945-111-35-19
25	1	Wash Thermometer Decal, Wash	06685-111-87-13 09905-002-97-61
26	1	Rinse Thermometer Decal, Rinse	06685-111-68-49 09905-002-97-62
27	1	Decal, Gauge	09905-021-82-65

## ITEMS NOT SHOWN

Grommet, 1/2" OD x 3/8" ID	05325-011-46-73
Bushing	05975-210-09-00
Plug	05975-011-47-81
Control Box Cover	05700-031-66-88
Control Box Cover Hinge	05700-021-68-57
Control Box Cover Hinge Rod	05700-011-68-58
MANUAL/DELIME Switch	05930-301-22-18
MANUAL/DELIME Decal	09905-011-74-61
Copper Conductors Only Decal	09905-011-47-35
Control Box Leg	05700-011-71-47



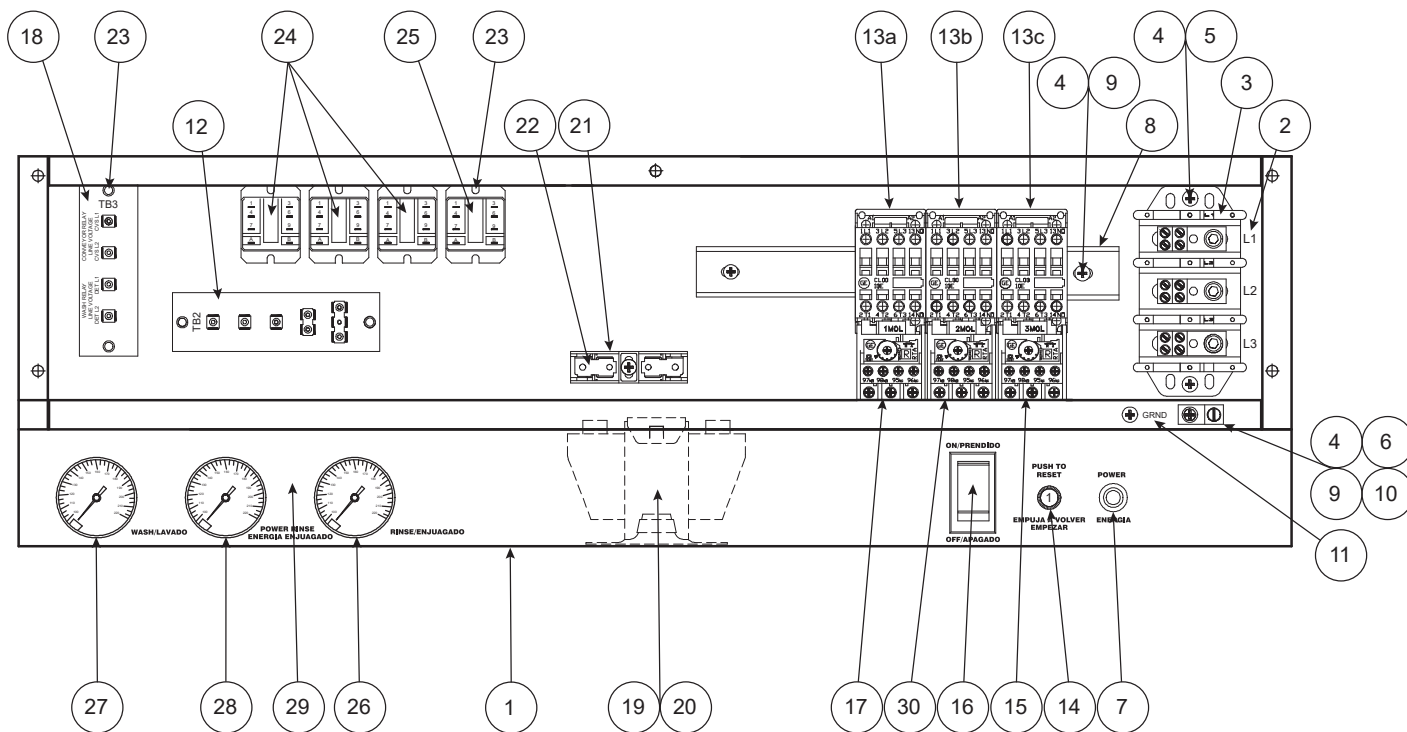

ITEM	QTY	DESCRIPTION	PART NUMBER
1	1	Electrical Box	05700-041-88-50
2	1	Decal, L1-L2-L3	09905-004-37-05
3	1	Terminal Block	05940-011-48-27
4	6	Lockwasher, #10	05311-273-02-00
5	2	Screw, 10-32 x 3/4" Phillips Trusshead	05305-011-62-17
6	1	Wire Lug, 2 AWG to 14 AWG	05940-200-76-00
7	1	Light, Red (Power)	05945-111-44-45
8	1	Din Rail	05700-021-94-96
9	3	Screw, 10-32 x 1/2" Phillips Trusshead	05305-011-39-36
10	1	Washer, Flat, 1/4"	05311-174-01-00
11	1	Decal, Ground	09905-011-86-86
12	1	Terminal Board	05940-002-78-97
13a	1	Drive Motor Contactor	05945-111-68-38
13b	1	Wash Pump Motor Contactor	05945-111-68-38
13c	1	Recirculating Rinse Pump Motor Contactor	05945-111-68-38
14	1	Circuit Breaker (208-230 V, 60 Hz Models Only)	05925-011-68-34
15	1	Recirculating Rinse Pump Motor Overload	See Motor Overloads page.

ITEM	QTY	DESCRIPTION	PART NUMBER
16	1	Switch, ON/FILL - OFF/DRAIN	05930-011-49-55
17	1	Drive Motor Overload	See Motor Overloads page.
18	1	Terminal Board	05940-021-89-41
19	1	Transformer	05950-002-46-10
20	4	Locknut, 10-24 with Nylon Insert	05310-373-01-00
21	1	Fuse Holder (460 V Only)	05920-011-72-89
22	1	Fuse (460 V Only)	05920-011-72-88
23	12	Screw, 6-32 x 3/8" Phillips Trusshead	05305-171-02-00
24	4	Control Relay, 2-pole	05945-111-35-19
25	1	Relay, 3-pole	05945-111-72-51
26	1	Rinse Thermometer, 96" (L-R & R-L) Decal, Rinse	06685-111-68-49 09905-002-97-62
27	1	Power Rinse Thermometer, 96" (L-R) Power Rinse Thermometer, 120" (R-L) Decal, Power Rinse	06685-111-68-49 09905-111-87-13 09905-003-01-31
28	1	Wash Thermometer, 120" (L-R) Wash Thermometer, 96" (R-L) Decal, Wash	06685-111-87-13 06685-111-68-49 09905-002-97-61
29	1	Pre-Wash Thermometer, 120" (L-R & R-L)	06685-111-87-13
30	1	Wash Pump Motor Overload	See Motor Overloads page.

## ITEMS NOT SHOWN

Grommet, 1/2" OD x 3/8" ID	05325-011-46-73
Bushing	05975-210-09-00
Plug	05975-011-47-81
Control Box Cover	05700-031-66-88
Control Box Cover Hinge	05700-021-68-57
Control Box Cover Hinge Rod	05700-011-68-58
MANUAL/DELIME Switch	05930-301-22-18
MANUAL/DELIME Decal	09905-011-74-61
Copper Conductors Only Decal	09905-011-47-35
Control Box Leg	05700-011-71-47

**AJ-44**

VOLTS	Hz	PHASE	DRIVE MOTOR	PRE-WASH MOTOR	WASH MOTOR	POWER RINSE MOTOR
208	60	1	N/A	N/A	N/A	N/A
230	60	1	N/A	N/A	N/A	N/A
208	60	3	05945-111-68-39	N/A	05945-111-68-40	05945-111-68-40
230	60	3	05945-111-68-39	N/A	05945-111-68-40	05945-111-68-40
460	60	3	05945-111-69-12	N/A	05945-111-68-41	05945-111-68-41

**AJ-66**

VOLTS	Hz	PHASE	DRIVE MOTOR	PRE-WASH MOTOR	WASH MOTOR	POWER RINSE MOTOR
208	60	1	N/A	N/A	N/A	N/A
230	60	1	N/A	N/A	N/A	N/A
208	60	3	05945-111-68-39	05945-111-68-41	05945-111-68-40	05945-111-68-40
230	60	3	05945-111-68-39	05945-111-68-41	05945-111-68-40	05945-111-68-40
460	60	3	05945-111-69-12	05945-111-69-13	05945-111-68-41	05945-111-68-41

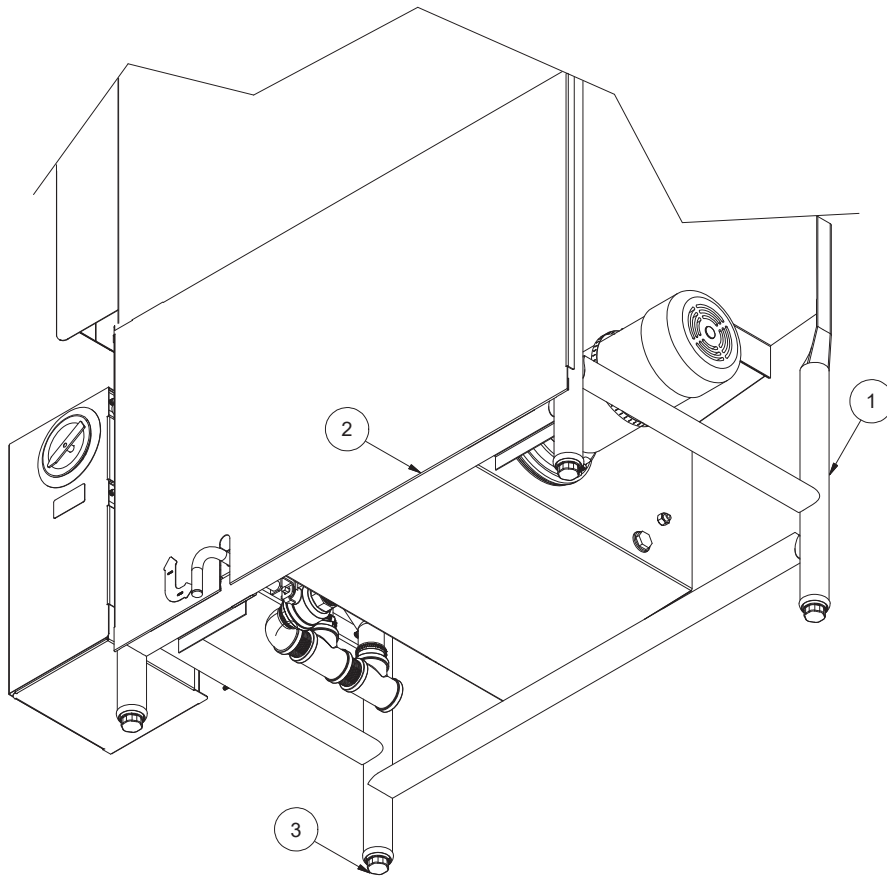

ITEM	QTY	DESCRIPTION	PART NUMBER
1	1	Frame Weldment (AJ-44) Frame Weldment (AJ-66 L-R) Frame Weldment (AJ-66 R-L)	05700-002-52-70 05700-002-49-28 05700-002-57-57
2	1	Front Dress Panel (AJ-44) Front Dress Panel (AJ-66 L-R) Front Dress Panel (AJ-66 R-L)	05700-002-52-77 05700-002-51-22 05700-002-57-84
3	4	Adjustable Foot	05340-011-71-74

**SHOCK ABSORBER (WATER ARRESTOR) OPTION**

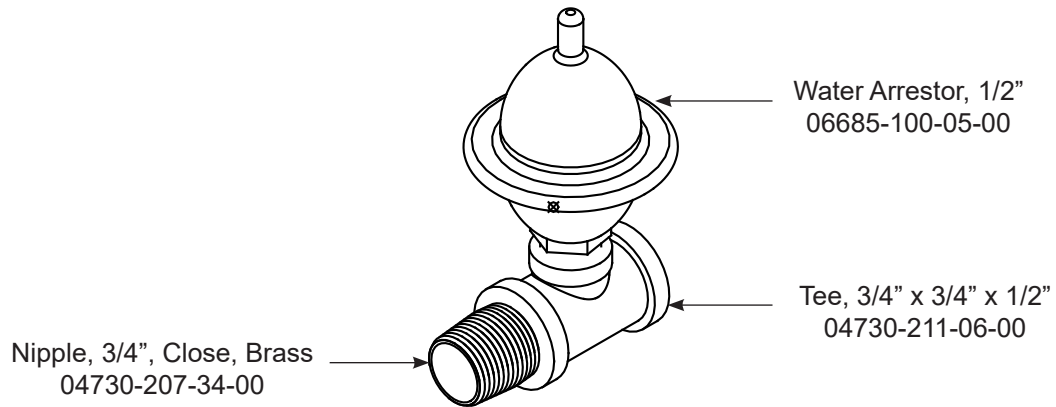

**WATER TREATMENT OPTION**

Scaltrol System  
04730-003-05-76

Replacement Cartridge  
(inspect at least every 6 months)  
RSC-100

Complete Pre-wash Plumbing Assembly  
05700-031-74-83

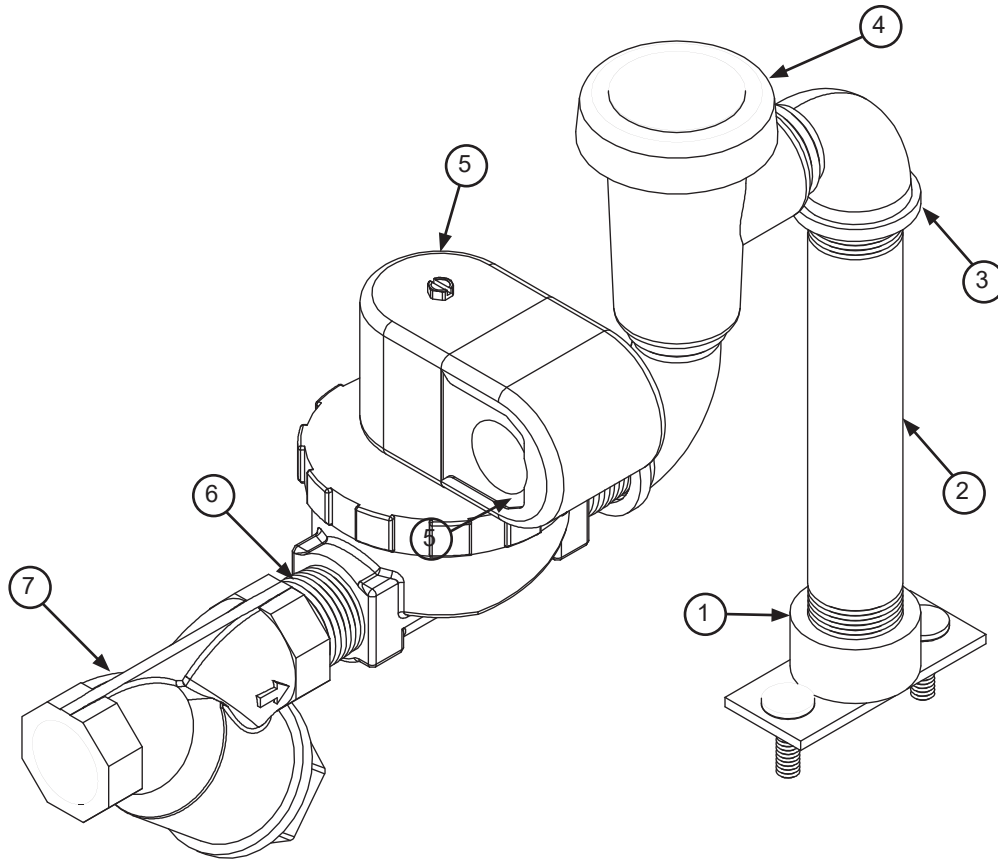

ITEM	QTY	DESCRIPTION	PART NUMBER
1	1 1	Fill Line Injector Gasket, Fill Line Injector	05700-011-67-99 05330-111-42-81
2	1	Nipple, 3/4" x 6"	05700-001-26-74
3	2	Elbow, 90-degree, Brass, 3/4"	04730-206-04-34
4	1	Vacuum Breaker, 3/4"	04820-002-53-77
5	1	Valve, Solenoid, 3/4"	04730-100-53-00
6	2	Nipple, Brass, Close, 3/4"	04730-207-34-00
7	1	Y-strainer, 3/4"	04730-717-02-06

Complete Plumbing Assembly  
05700-002-51-17

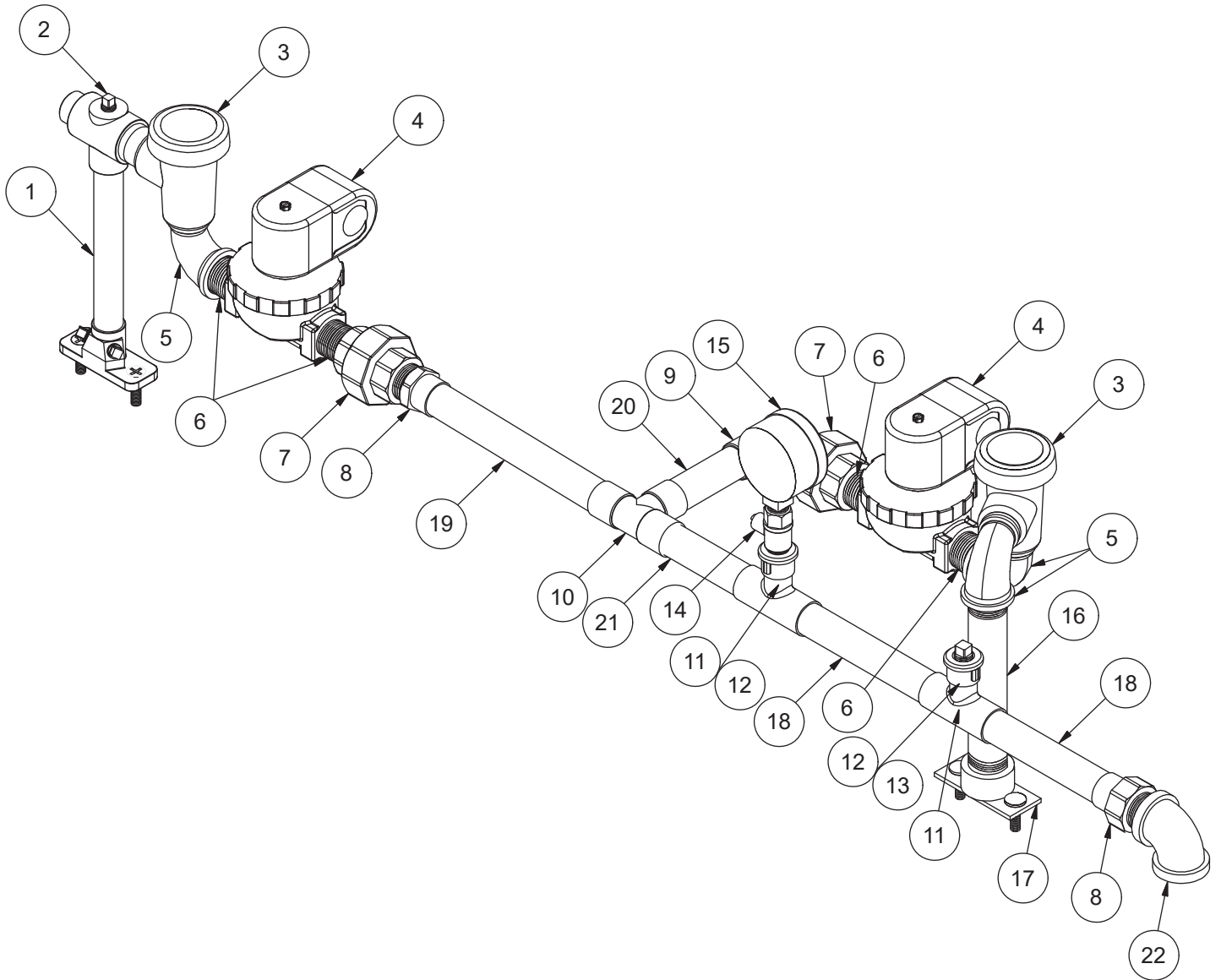

ITEM	QTY	DESCRIPTION	PART NUMBER
1	1	Kit, Rinse Injector	05700-002-57-87
	1	Gasket, Injector	05330-111-42-81
2	3	Plug, 1/8", Brass	04730-209-07-37
3	2	Vacuum Breaker, Brass, 3/4"	04820-002-53-77
4	2	Valve, Solenoid, 3/4"	04810-100-53-00
5	3	Elbow, 90-degree, Brass, 3/4"	04730-206-04-34
6	4	Nipple, Brass, 3/4" x 1 3/8"	04730-207-34-00
7	4	Union, Brass, 3/4"	04730-212-05-00
8	2	Adapter, Female, 3/4"	04730-401-11-01
9	1	Elbow, 90-degree, Copper	04730-406-42-01
10	1	Tee, Copper, 3/4"	04730-411-46-01
11	2	Tee, Copper, 3/4" x 3/4" x 1/2"	04730-411-03-01
12	2	Fitting, Adapter, 1/2" to 1/4"	04730-401-41-01
13	1	Plug, 1/4", Brass	04730-209-01-00
14	1	Valve, Ball, 1/4"	04810-011-72-67
15	1	Gauge, Pressure, 0–100 PSI	06685-111-88-34
	1	Decal, 15–25 PSI	09905-002-97-74
16	1	Nipple, Brass, 3/4" x 6"	05700-001-26-74
17	1	Injector, Fill Line	05700-011-67-99
	1	Gasket, Injector	05330-111-42-81
18	1	Tube, Copper, 3/4" x 2 13/16"	See note below.
19	1	Tube, Copper, 3/4" x 3 7/16"	See note below.
20	1	Tube, Copper, 3/4" x 3"	See note below.
21	1	Tube, Copper, 3/4" x 2 5/8"	See note below.
22	1	Elbow, 90-degree, Brass, 3/4"	04730-206-13-00

**NOTICE** Copper tubing should be purchased locally and cut to length shown in the part description.



Complete Rinse Header  
Plumbing Assembly  
05700-002-51-16

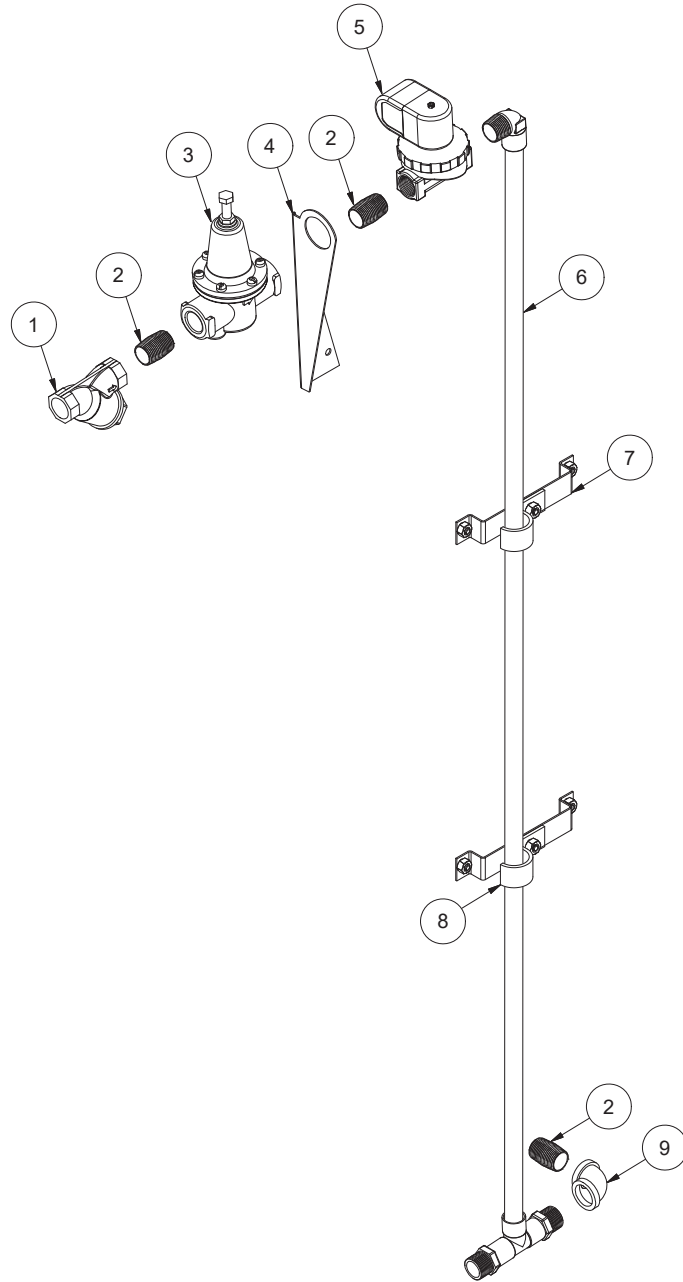

ITEM	QTY	DESCRIPTION	PART NUMBER
1	1	Y-strainer, Brass, 3/4"	04730-717-02-06
2	2	Nipple, Brass, 3/4"	04730-207-34-00
3	1	Pressure Regulator, 3/4"	04820-002-51-53
4	1	Bracket, Plumbing Support	05700-002-50-70
5	1	Valve, Solenoid, 3/4"	04810-100-53-00
6	1	Incoming Piping Assembly	05700-002-51-15
7	2	Bracket, Inlet Plumbing Mounting	05700-002-51-41
8	2	Clamp, Pipe	05700-000-35-06
9	1	Elbow, 90-degree, Brass, 3/4"	04730-206-13-00

Complete Coil Assembly, L-R  
05700-041-88-31

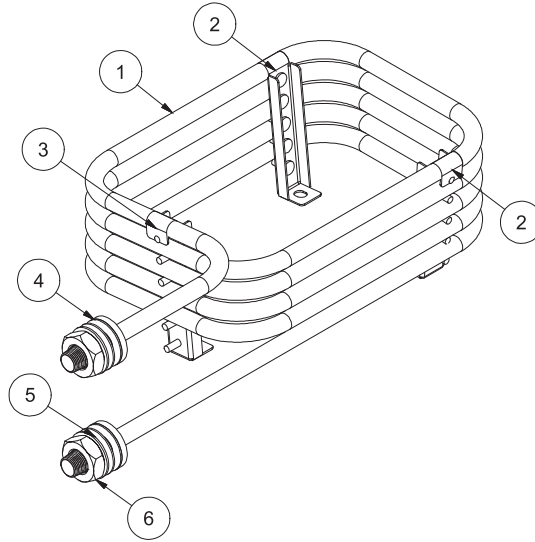

ITEM	QTY	DESCRIPTION	PART NUMBER
1	1	Coil	05700-031-88-30
2	2	Stand "A"	05700-002-74-82
3	1	Stand "C"	05700-002-74-84
4	4	Coil Gasket	05700-001-17-86
5	2	Flat Washer	05700-001-17-87
6	2	Coil Nut	05310-011-17-85

Complete Coil Assembly, R-L  
05700-002-81-44

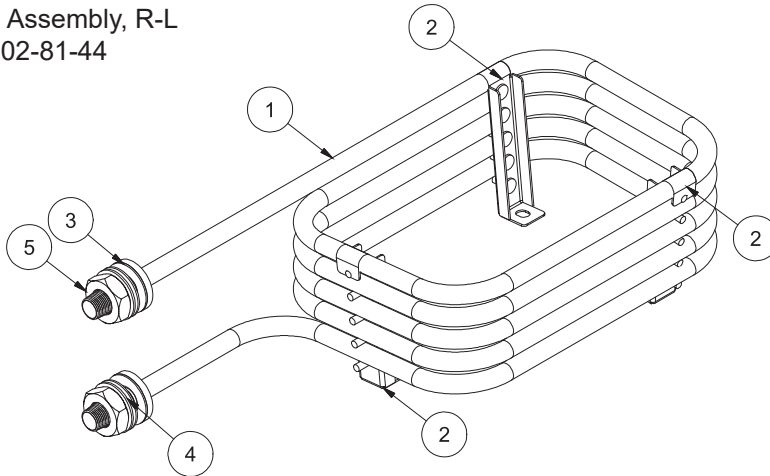

ITEM	QTY	DESCRIPTION	PART NUMBER
1	1	Coil	05700-031-88-30
2	3	Stand "A"	05700-002-74-82
3	4	Coil Gasket	05700-001-17-86
4	2	Flat Washer	05700-001-17-87
5	2	Coil Nut	05310-011-17-85

**NOTICE** The coil gaskets should be replaced any time the coil is replaced or removed for an extended period of time.

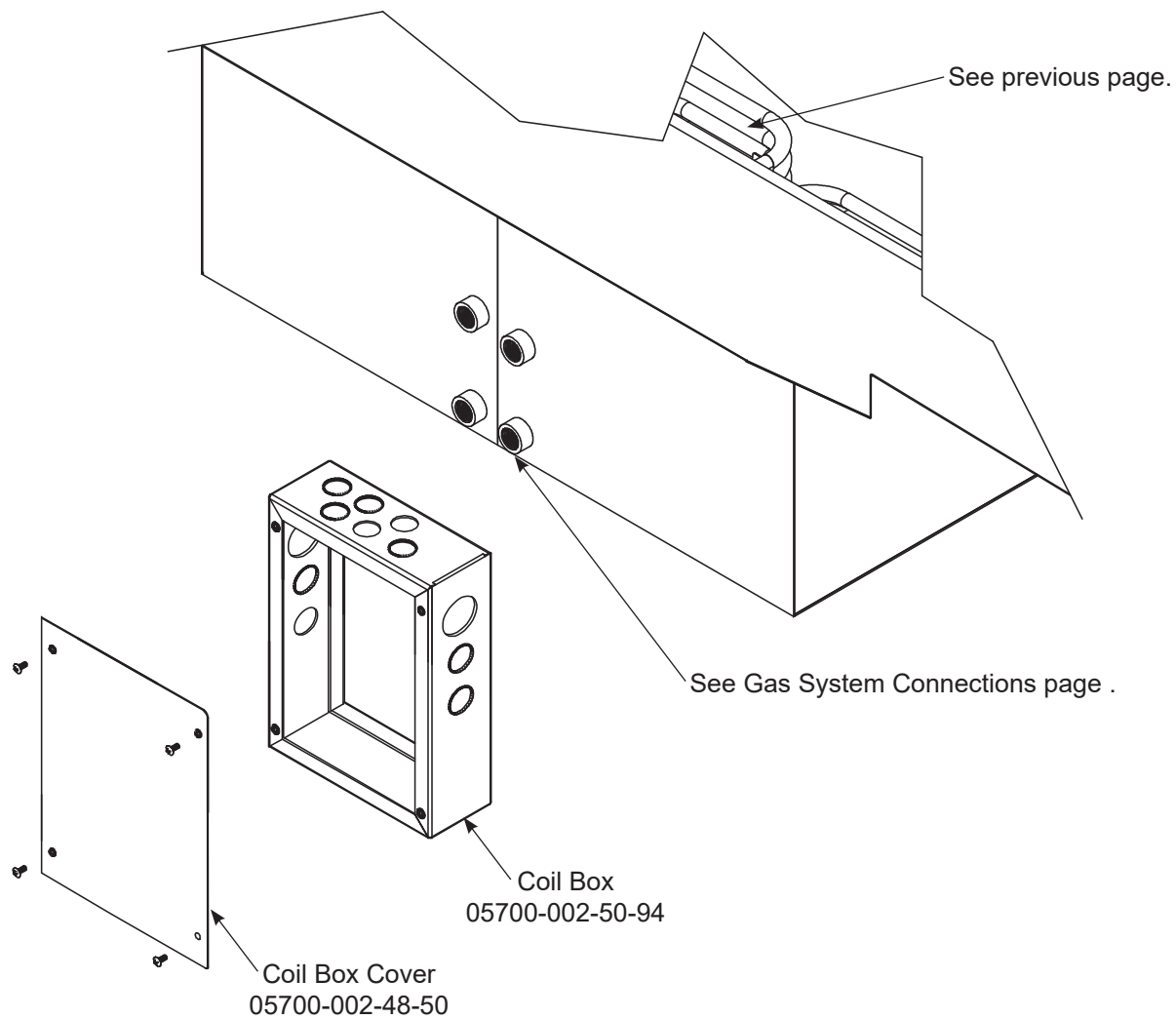

**Items Not Shown:**

ITEM	QTY	DESCRIPTION	PART NUMBER
1	1	Thermostat, High-Limit	05930-011-49-43
2	1	Gasket	05330-200-02-70
3	1	Terminal Board	05940-002-78-97
4	1	Thermostat Bracket	05700-011-81-64
5	1	Decal, Thermostat Regulating	09905-011-84-31
6	1	Thermostat, Wash Regulating	06401-140-00-32
7	1	Fitting, Brass, 1/4"	05310-924-02-05

Complete Tank Assembly  
05700-002-45-05

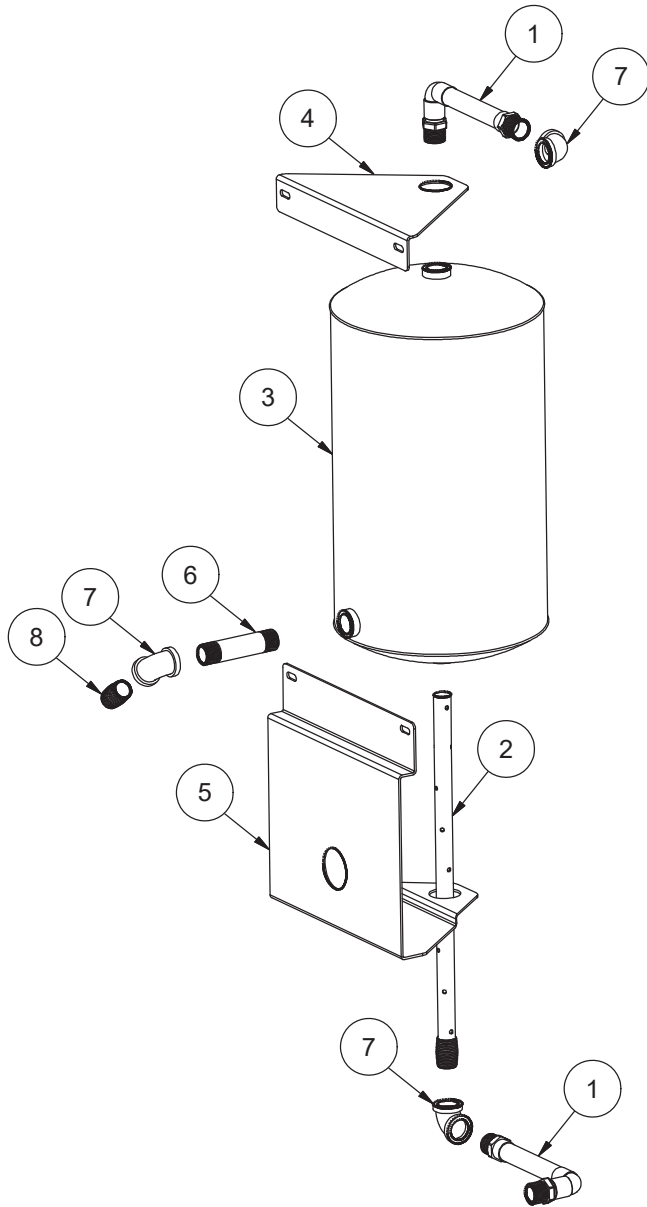

**Bottom Angled View**

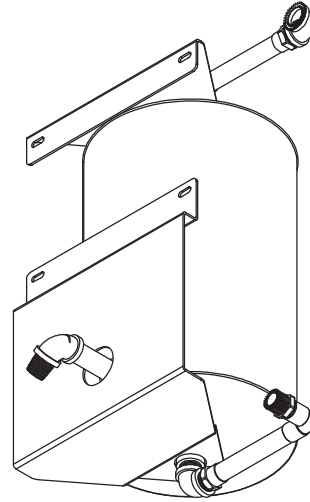

**Top Angled View**

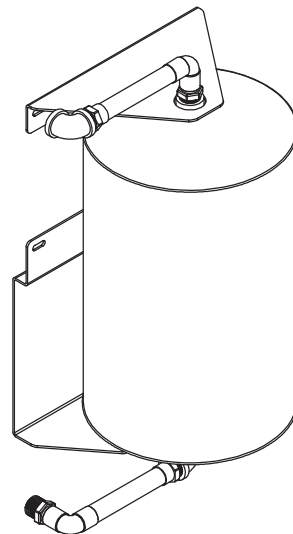

ITEM	QTY	DESCRIPTION	PART NUMBER
1	2	Plumbing Assembly, Rinse Tank	05700-002-51-24
2	1	Tube, Dispersion	05700-002-46-16
3	1	Tank, Rinse	05700-002-45-05
4	1	Bracket, Upper Rinse Tank	05700-002-67-13
5	1	Bracket, Lower Rinse Tank	05700-002-67-14
6	1	Nipple, 3/4" x 4"	04730-207-05-00
7	3	Elbow, 90-degree, Brass, 3/4"	04730-206-13-00
8	1	Nipple, Brass, 3/4"	04730-207-34-00

Complete Recirculating Pump Assembly  
 05700-002-51-29  
 (Does not include bracket.)

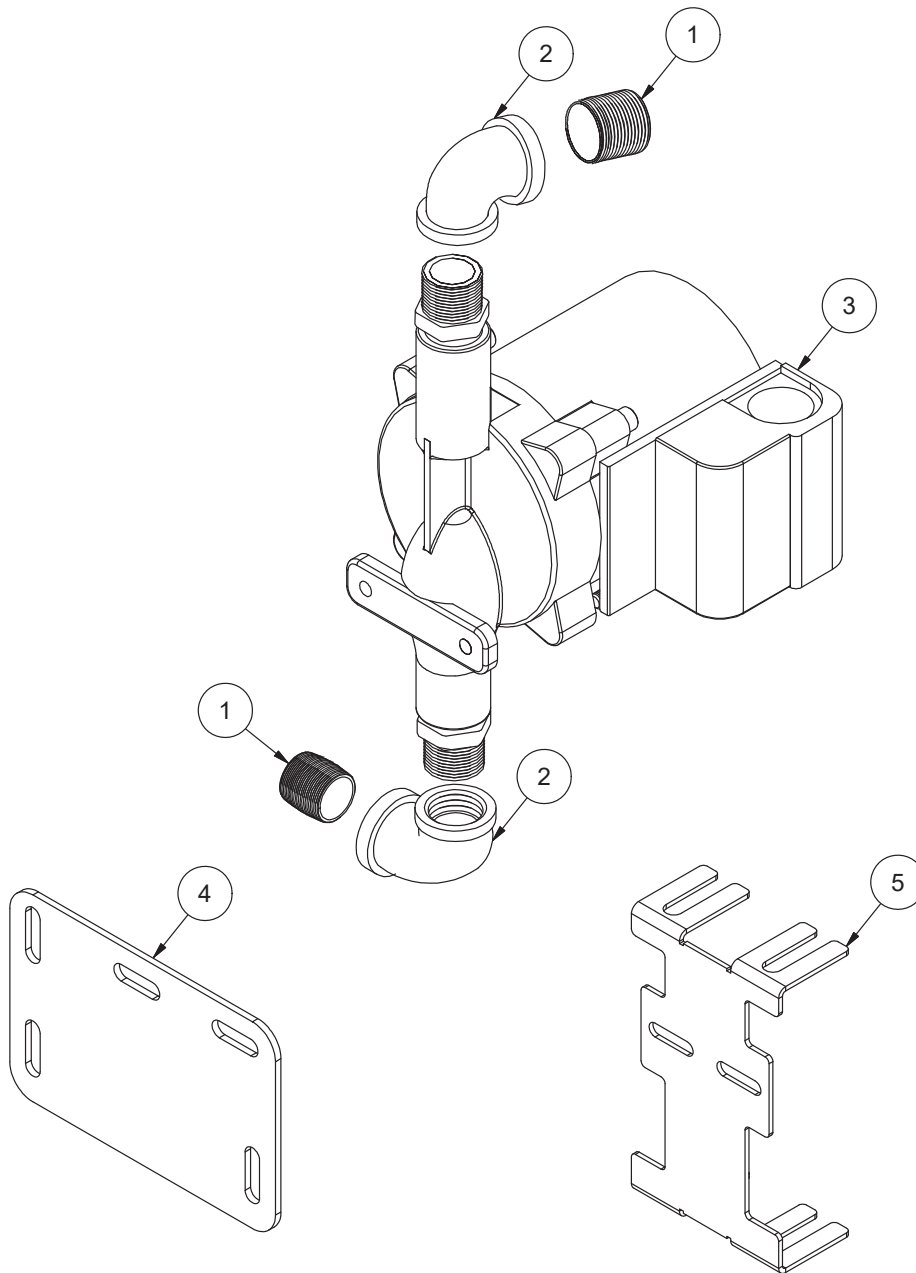

ITEM	QTY	DESCRIPTION	PART NUMBER
1	2	Nipple, Brass, 3/4"	04730-207-34-00
2	2	Elbow, 90-degree, Brass, 3/4"	04730-206-13-00
3	1	Pump, Recirculating Pump, Recirculating Modified Pump, Recirculating with Adapters	06105-002-05-26 05700-002-81-22 05700-002-51-28
4	1	Bracket, Mounting (AJ-66 L-R)	05700-002-25-74
5	1	Bracket, Mounting (All Other Models)	05700-004-61-85

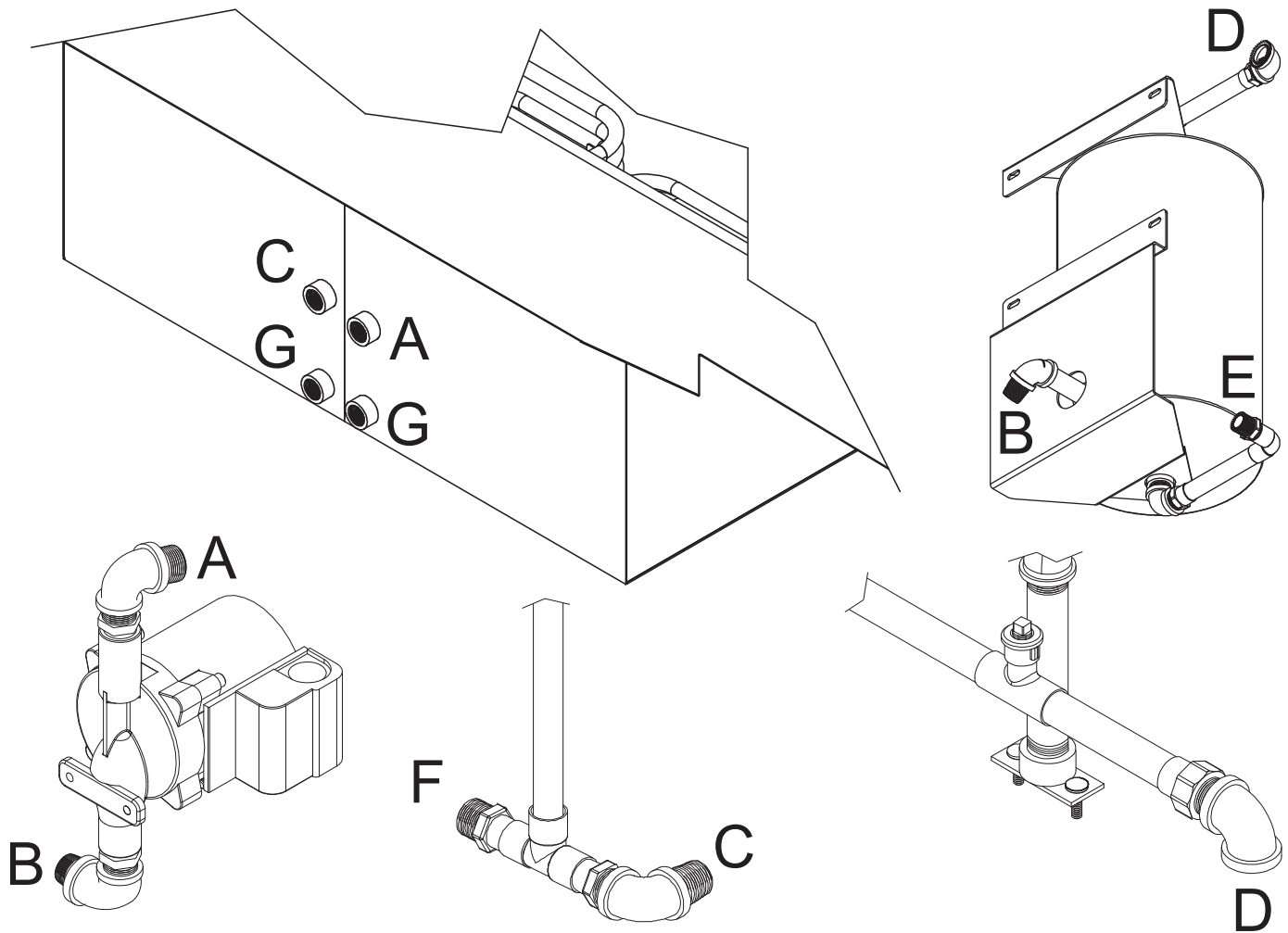

ITEM	DESCRIPTION	AJ-44	AJ-66/80
A	Hose, Recirculating Discharge	05700-002-52-74	05700-002-52-76
B	Hose, Recirculating Pump Suction	05700-002-52-75	05700-002-51-38
C	Hose, Wash Coil Assembly	05700-002-52-76	04720-011-94-10
D	Hose, Wash/Fill Supply	05700-003-03-97	05700-003-03-99
E	Connection, Hose to Gas Booster Outlet	-	-
F	Connection, Hose to Gas Booster Inlet	-	-
G	Hose, Coil Recirculating	05700-002-17-71	05700-002-17-71
-	Kit, Gas Booster Connection (18' of Hose, Four 3/4" Fittings)	05700-002-51-73	05700-002-51-73

**NOTICE** Each hose assembly includes two 3/4" fittings, 04730-011-94-00.

Complete AJ-44 Drain Plumbing Assembly  
05700-002-52-71

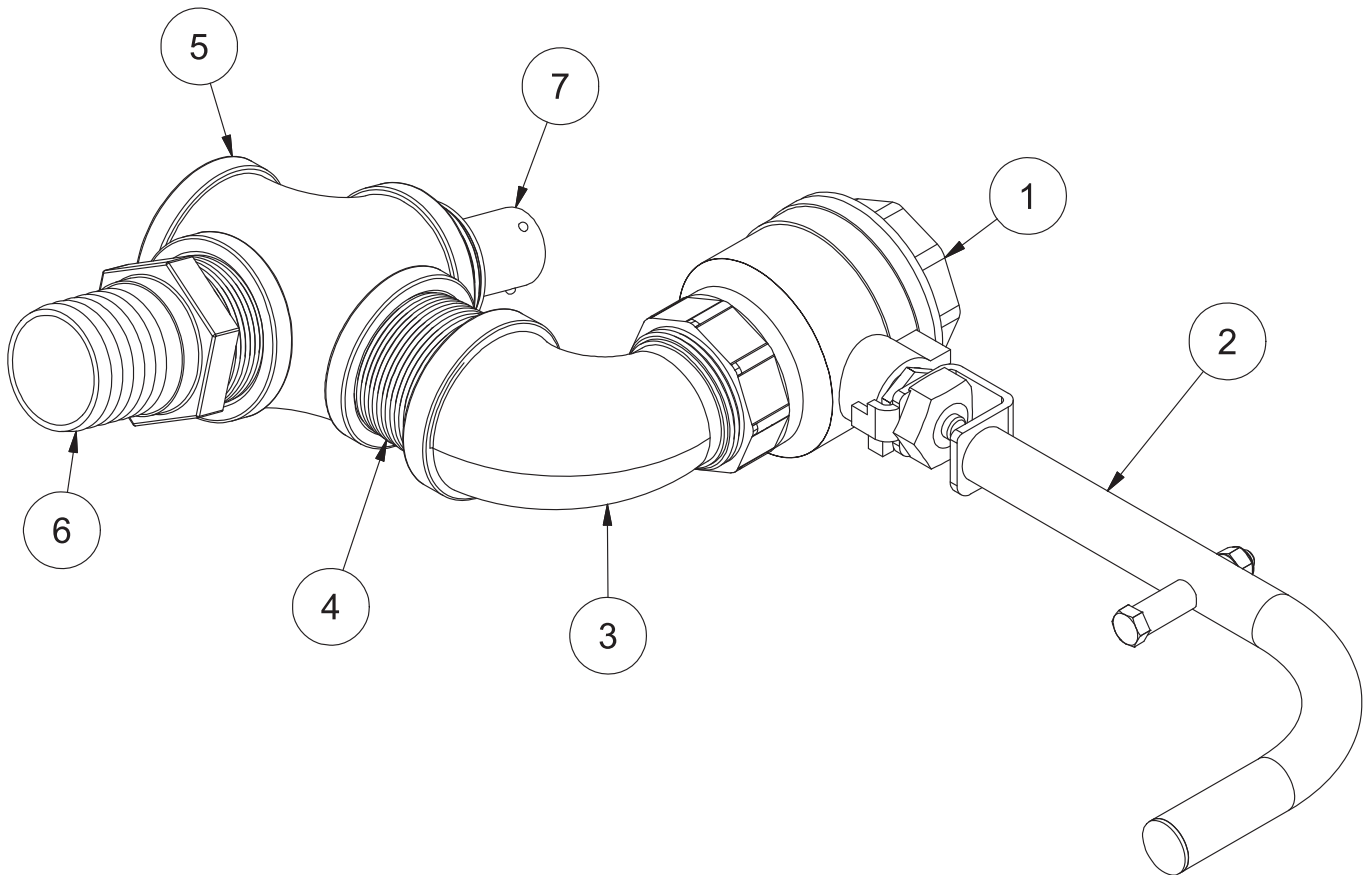

ITEM	QTY	DESCRIPTION	PART NUMBER
1	1	Valve, Ball, 1 1/2"	04820-111-71-46
2	1 1	Ball Valve Handle Assembly Spacer (Not Shown)	05700-021-84-74 05700-002-87-05
3	1	Elbow, 90-degree, Street Brass, 1 1/2"	04730-206-32-00
4	1	Nipple, Brass, 1 1/2"	04730-207-40-00
5	1	Cross Connector, 1 1/2"	04710-004-43-65
6	1	Fitting, Barbed, 1 1/2" x 1 1/2"	04730-011-69-92
7	1	Rinse Nipple	05700-021-84-61

Complete AJ-66 Drain Plumbing Assembly, L-R  
05700-002-50-95

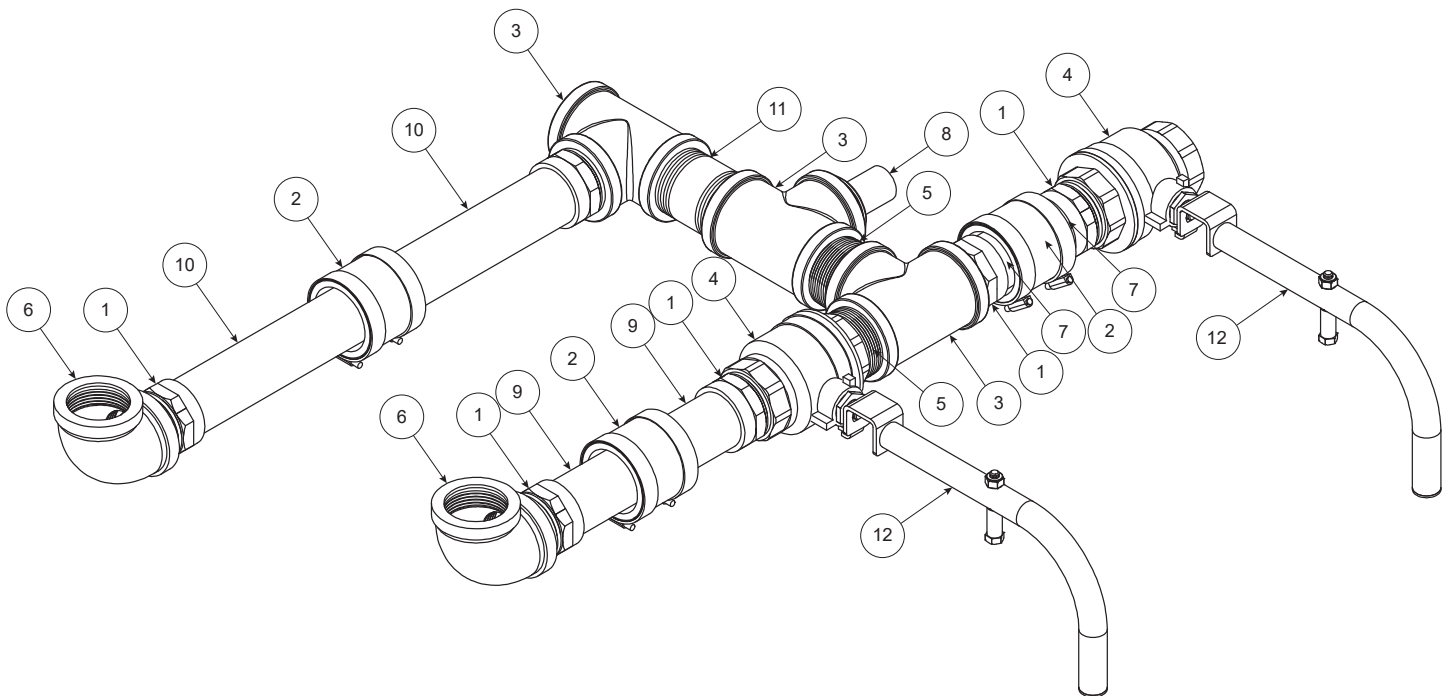

ITEM	QTY	DESCRIPTION	PART NUMBER
1	6	Adapter, 1 1/2"	04730-401-25-01
2	3	Connector, No-hub, 1 1/2"	04720-003-73-73
3	3	Tee, Brass, 1 1/2"	04730-011-69-93
4	2	Ball Valve, 1 1/2"	04820-011-71-46
5	2	Nipple, Close Brass, 1 1/2"	04730-207-40-00
6	2	Elbow, Brass, 90-degree, 1 1/2"	04730-011-73-77
7	2	Tube, Copper, 1 1/2" x 1 3/4"	See note below.
8	1	Nipple, Rinse	05700-021-84-61
9	2	Tube, Copper, 1 1/2" x 3 1/2"	See note below.
10	2	Tube, Copper, 1 1/2" x 7 1/2"	See note below.
11	1	Nipple, Brass, 1 1/2" x 3"	04730-011-87-04
12	2	Handle, Ball Valve	05700-021-84-74
	2	Spacer (Not Shown)	05700-002-87-05

**NOTICE** Copper tubing should be purchased locally and cut to the length shown in the part description.



Complete AJ-66 Drain Plumbing Assembly, R-L  
05700-002-57-59

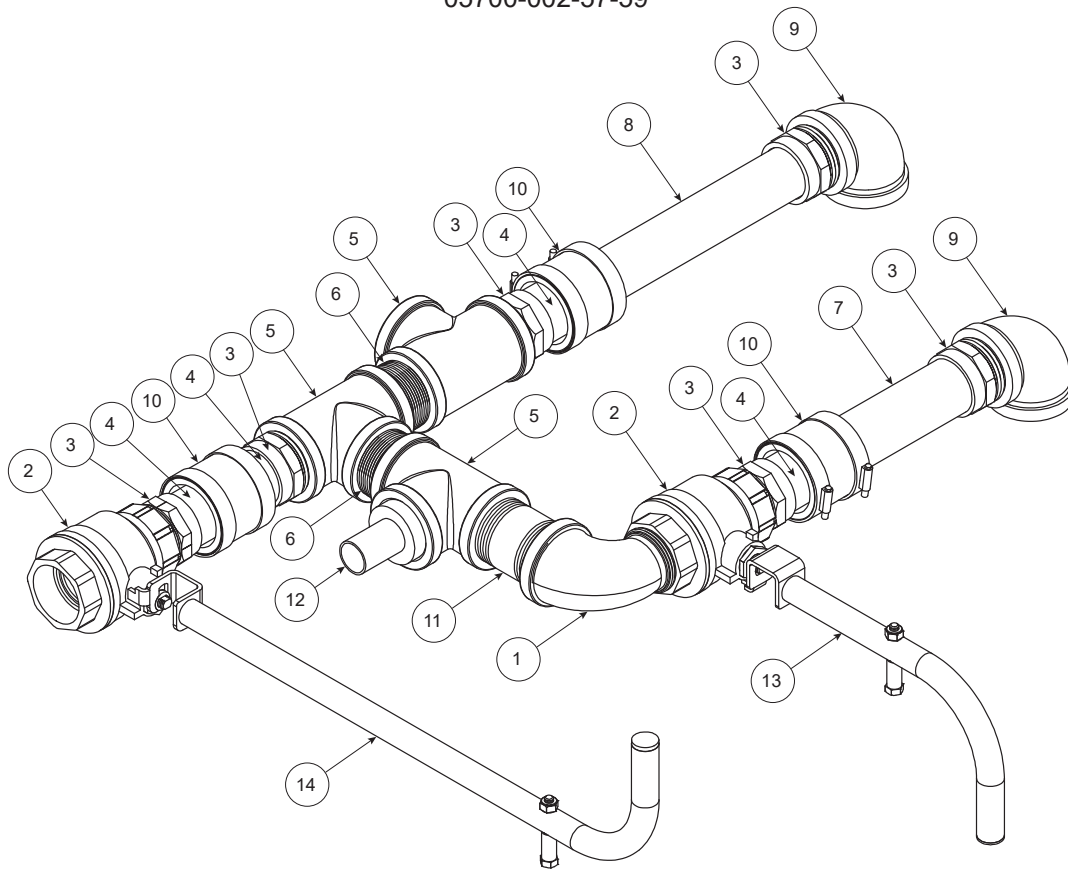

ITEM	QTY	DESCRIPTION	PART NUMBER
1	1	Elbow, 1 1/2", Street Brass	04730-206-32-00
2	2	Ball Valve, 1 1/2"	04820-011-71-46
3	6	Adapter, 1 1/2"	04730-401-25-01
4	4	Tube, Copper, 1 1/2" x 1 7/8"	See note below.
5	3	Tee, Brass, 1 1/2"	04730-011-69-93
6	2	Nipple, Close Brass, 1 1/2"	04730-207-40-00
7	2	Tube, Copper, 1 1/2" x 5 3/16"	See note below.
8	2	Tube, Copper, 1 1/2" x 8 1/8"	See note below.
9	2	Elbow, Brass, 90-degree, 1 1/2"	04730-011-73-77
10	3	Connector, No-hub, 1 1/2"	04720-003-73-73
11	1	Nipple, Brass, 1 1/2" x 3"	04730-011-87-04
12	1	Nipple, Rinse	05700-021-84-61
13	1	Handle, Ball Valve	05700-021-84-74
	1	Spacer (Not Shown)	05700-002-87-05
14	1	Handle, Ball Valve, Long	05700-002-57-83
	1	Spacer (Not Shown)	05700-002-87-05

**NOTICE** Copper tubing should be purchased locally and cut to the length shown in the part description.

# SOLENOID VALVE & VACUUM BREAKER

Complete 110 V Valve Assembly, 3/4"  
04810-100-53-00

Coil & Housing Only  
04810-200-01-18

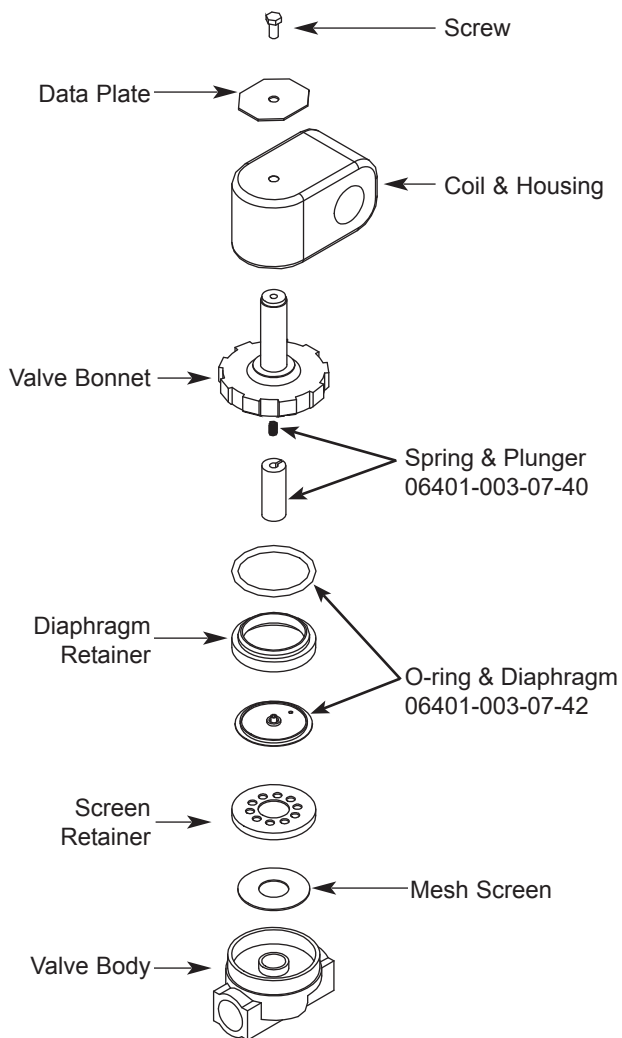

Complete Vacuum Breaker Assembly, 3/4"  
04820-002-53-77

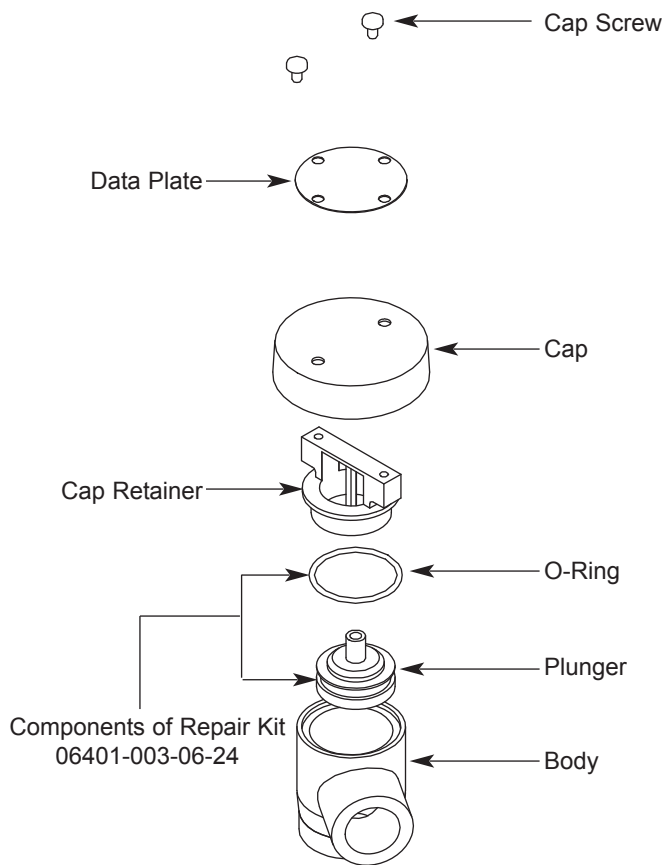

**Complete Vacuum Breaker Assembly**  
04820-002-53-77

Drain Water Tempering Kit  
06401-002-44-07

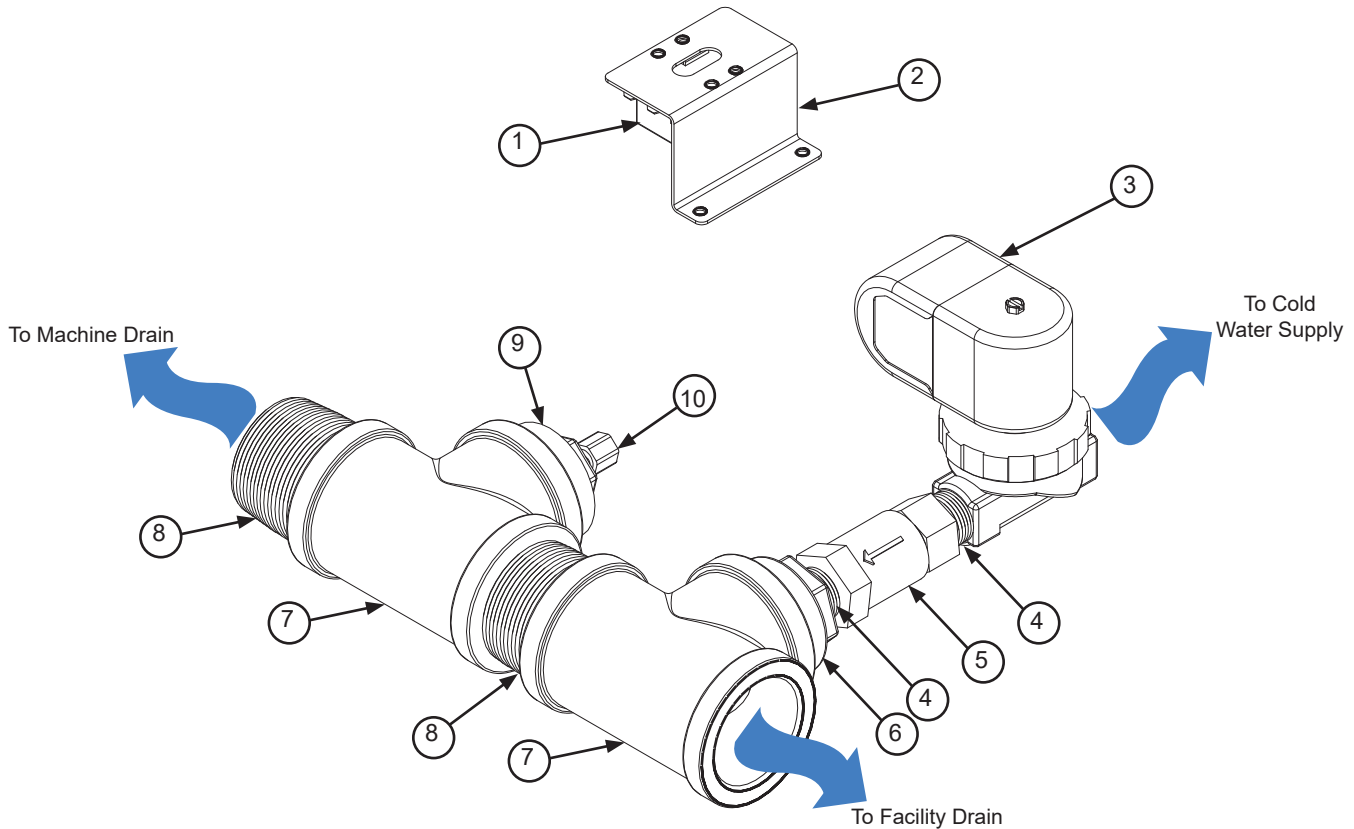

From the existing drain, attach the two additional Tees (Item 7) using the 1 1/2" Close Brass Nipples (Item 8). Tighten the Reducers (Items 6 and 9) into the Tees as shown above. Attach the Modified Compression Fitting (Item 10) into the 1 1/2" to 1/4" Reducer (Item 9). Position the bulb of the thermostat (Item 1) so that it rests approximately 1/4" from the bottom of the Tee (Item 7). Tighten the Modified Compression Fitting (Item 10) as required.

Mount the Thermostat (Item 1) to the tub using the Thermostat Bracket (Item 2) and set it for 120 °F - 140 °F. Install the Solenoid Valve (Item 3) to the second Tee (Item 7) and then attach to the incoming cold water line. Use thread tape as required to prevent any leaks.

ITEM	QTY	DESCRIPTION	PART NUMBER
1	1	Thermostat	05930-003-13-65
2	1	Thermostat Bracket	05700-011-81-64
3	1	Solenoid Valve	04810-100-12-18
4	2	Nipple, Close Brass, 1/2"	04730-207-15-00
5	1	Valve, Check, 1/2"	04820-002-55-77
6	1	Reducer, 1 1/2" to 1/2"	04730-002-55-75
7	2	Tee, 1 1/2" x 1 1/2" x 1 1/2"	04730-011-69-93
8	2	Nipple, Close Brass, 1 1/2"	04730-207-40-00
9	1	Reducer, 1 1/2" to 1/4"	04730-002-55-76
10	1	Modified Compression Fitting	05700-001-16-52

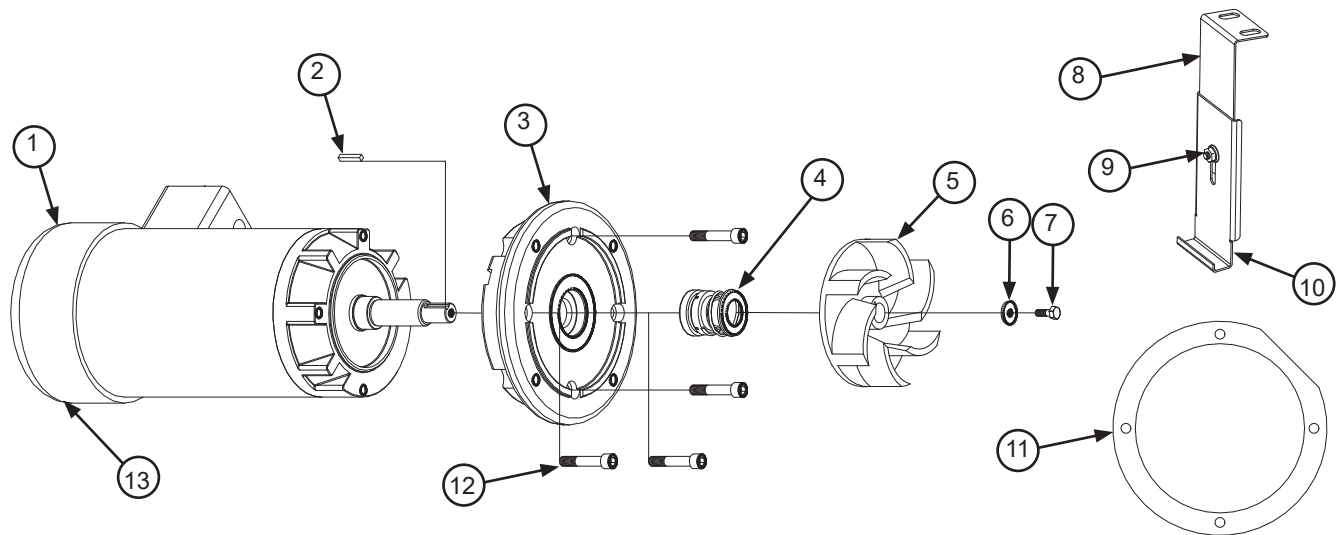

ITEM	QTY	DESCRIPTION	PART NUMBER
1	1	Motor	See table on the next page.
2	1	Key, 3/16" x 1"	05700-011-89-17
3	1	Pump Plate	05700-021-71-83
4	1	Pump Seal	05330-011-71-98
5	1	Wash Impeller	05700-031-67-45
	1	Power Rinse Impeller (AJ-80)	05700-031-67-45
	1	Pre-wash Impeller (AJ-66/80)	05700-031-71-78
6	1	Impeller Washer	05700-011-71-95
7	1	Bolt, Hex Head 1/4-20 x 3/4"	05305-004-42-64
8	1	Upper Support Bracket	05700-021-73-68
9	1	Nut, 1/4-20 Serrated	05310-011-66-49
10	1	Lower Support Bracket	05700-021-73-71
11	1	Motor Mounting Gasket	05330-011-71-62
12	4	Cap Screw, 3/8-16 x 2"	05305-011-74-98
13	1	Motor Mounting Clamp, 4 1/8" to 7" (Not Shown)	04730-002-32-15

Complete Motor Bracket Assembly  
 Items 8,9, and 10  
 05700-021-73-42

**WASH MOTORS**

Volts	Phase	Hz	Motor Part Number	Complete Kit Part Number
208-230	1	60	06105-021-70-57	06401-003-09-97
208-230	3	60	06105-121-70-58	06401-003-09-98
460	3	60	06105-121-70-58	06401-003-09-98

**PRE-WASH MOTORS**

AJ-66

Volts	Phase	Hz	Motor Part Number	Complete Kit Part Number
208-230	1	60	06105-121-70-55	06401-003-10-40
200-230	3	60	06105-121-70-56	06401-003-10-38
460	3	60	06105-121-70-56	06401-003-10-38

Parts are not shown to scale with relation to each other.

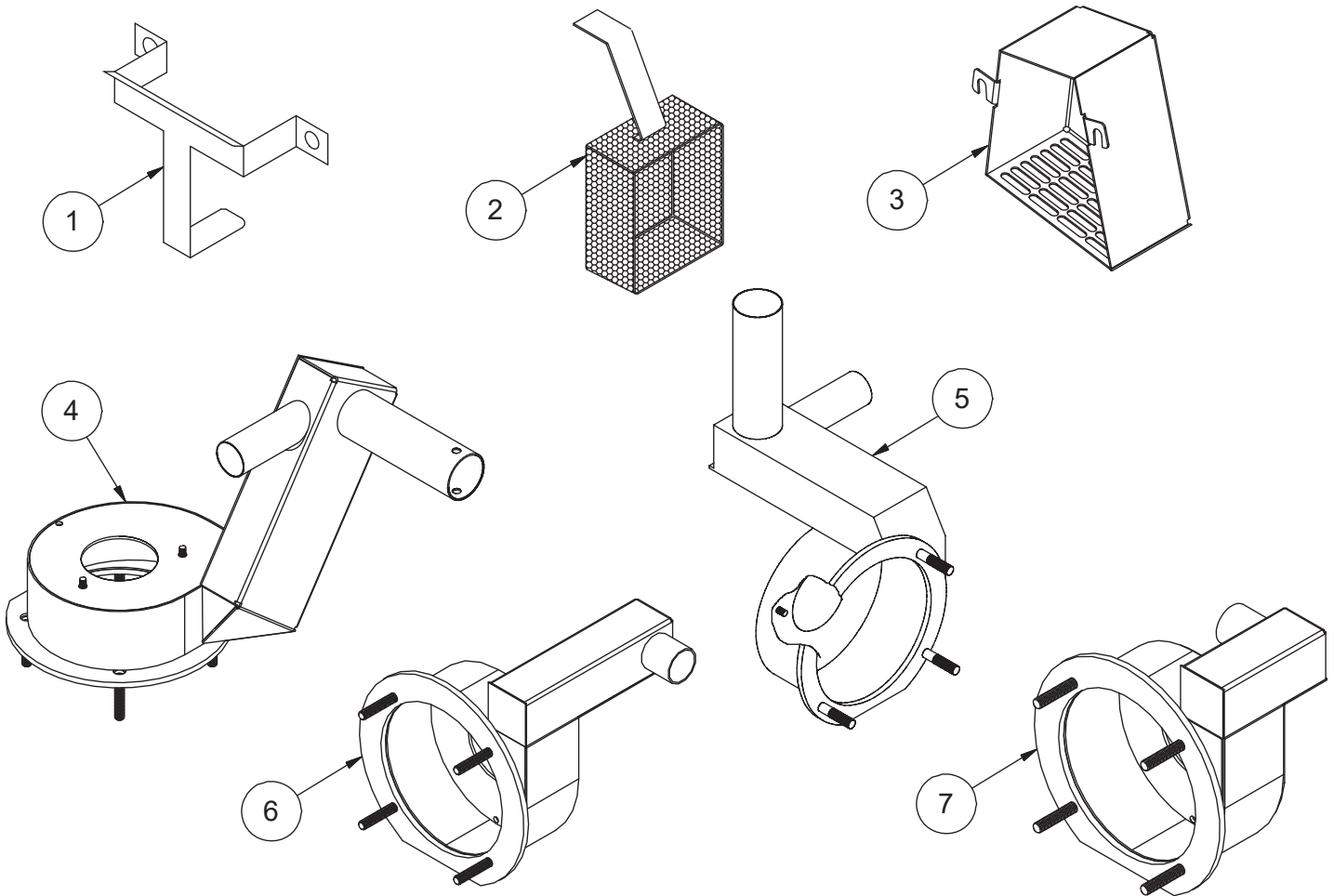

ITEM	QTY	DESCRIPTION	PART NUMBER
1	1	Pre-wash Strainer Bracket	05700-021-74-94
2	1	Pre-wash Intake Strainer	05700-021-74-96
3	1	Intake Suction Scoop	05700-021-87-60
4	1	Power Rinse Pump Weldment (AJ-80)	05700-031-81-47
5	1	Wash Pump Weldment (All Models)	05700-041-68-88
6	1	Pre-wash Pump Weldment (AJ-66/80 L-R)	05700-002-10-62
7	1	Pre-wash Pump Weldment (AJ-66/80 R-L)	05700-002-11-96

Pump weldments are secured to pump plates with the following (not shown):

8	Nut, Hex, 3/8-16	05310-276-01-00
9	Washer, Flat, 3/8"	05311-176-01-00
10	Lockwasher, Split, 3/8"	05311-276-01-00

# PRE-WASH & UPPER WASH ARM

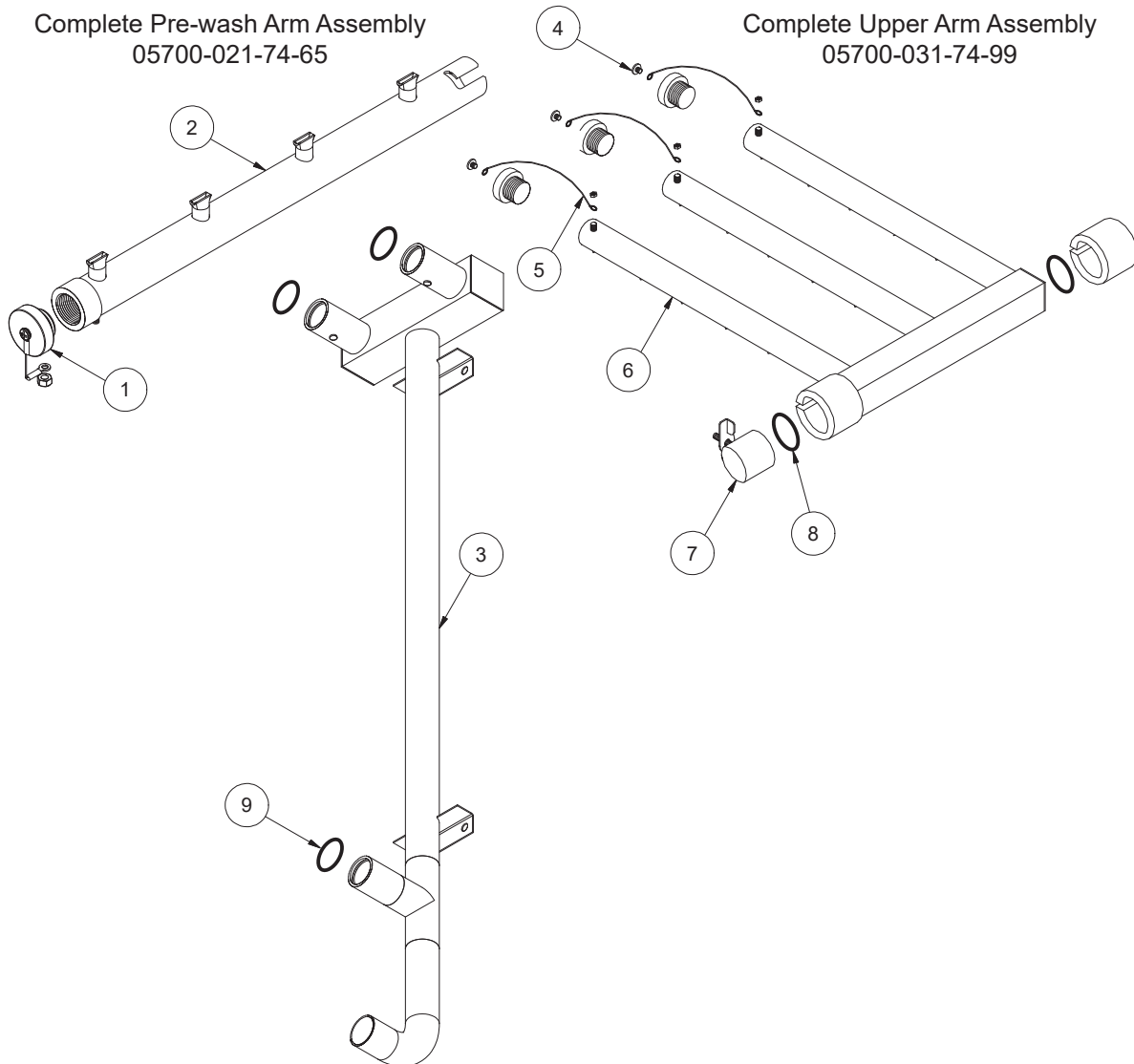

ITEM	QTY	DESCRIPTION	PART NUMBER
1	4	End-cap	05700-011-67-11
	4	End-cap Replacement Kit*	06401-003-10-19*
2	1	Pre-wash Tube (AJ-66/80)	05700-001-16-89
3	1	Pre-wash Manifold (AJ-66/80)	05700-031-69-70
4	4	Mounting Screw, End-cap, 10-32 x 3/8"	05305-173-12-00
5	4	Lanyard	05340-011-72-46
6	1	Upper Wash Arm	05700-031-67-34
7	1	Cap, Wash Tube	05700-021-69-68
8	2	O-ring, Upper Wash Arm	05330-011-74-56
9	3	O-ring, Pre-wash Manifold	05330-400-12-08
10	1	Upper Wash Manifold Support Bracket (Not Shown)	05700-021-73-97

\* Kit contains part(s) and all hardware.

**NOTICE** When replacing the screws in the end-caps, use a thread-locking product to ensure the mounting screws do not come loose during operation.

Complete Lower Wash Arm Assembly  
05700-031-74-66

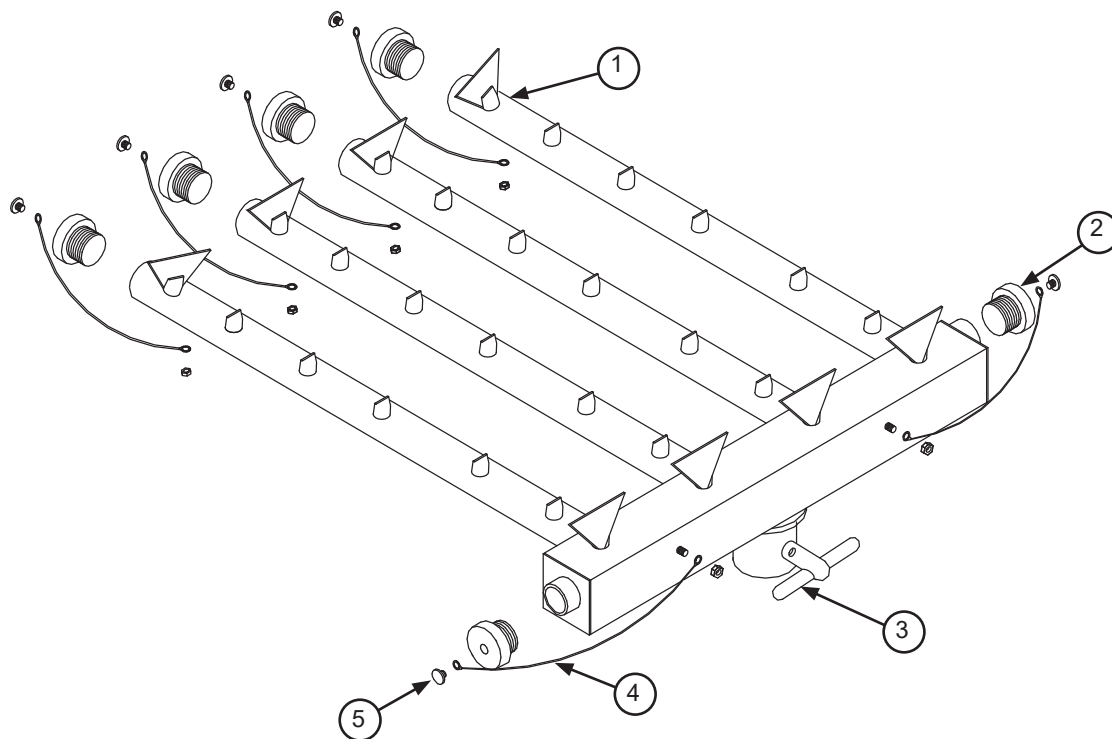

ITEM	QTY	DESCRIPTION	PART NUMBER
1	1	Lower Wash Arm	05700-031-67-29
2	6	End-cap	05700-011-67-11
	6	End-cap Kit*	06401-003-10-19*
3	1	Manifold Quick-Release Key	05700-011-94-45
4	6	Lanyard	05340-011-72-46
5	6	Mounting Screw, End-cap, 10-32 x 3/8"	05305-173-12-00
6	1	Bracket, Lower Wash Arm Support (Not Shown)	05700-011-71-20
7	2	Locknut, 1/4-20 with Nylon Insert (Not Shown)	05310-374-01-00

\* Kit contains part(s) and all hardware.

**NOTICE** When replacing the screws in the end-caps, use a thread-locking product to ensure the mounting screws do not come loose during operation.



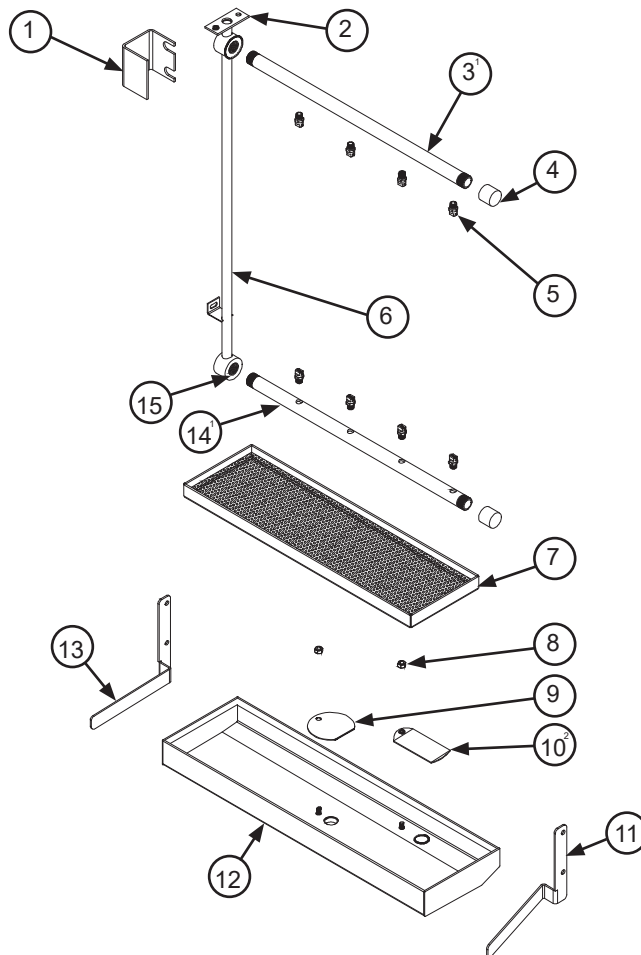

*\* Kits contain rinse arm, end-caps, o-rings, and retaining rings.*

ITEM	QTY	DESCRIPTION	PART NUMBER
1	1	Rinse Arm Support Bracket	05700-011-71-19
2	1	Gasket, Final Rinse Manifold	05330-111-42-81
3*	1	Upper Rinse Arm Kit	06401-003-10-08
4	2	End-cap	04730-209-07-37
5	8	Rinse Nozzle	04730-003-59-63
6	1	Final Rinse Manifold	05700-031-74-88
7	1	Rinse Pan Strainer	05700-041-85-09
8	2	Locknut, 1/4-20 with Nylon Insert	05310-374-01-00
9	1	Rinse Drain Control Plate	05700-011-68-70
10	1	Rinse Drain Overflow Plate	05700-002-53-62
11	1	Left Rinse Pan Locator Bracket	05700-021-92-38
12	1	Rinse Tray	05700-002-51-18
13	1	Right Rinse Pan Locator Bracket	05700-021-92-37
14 <sup>1</sup>	1	Lower Rinse Arm Kit	06401-003-10-09
15	2	O-ring	05330-011-74-55
16	2	Retaining Ring, Rinse Arm (Not Shown)	05340-112-01-11

Parts are not shown to scale with relation to each other.

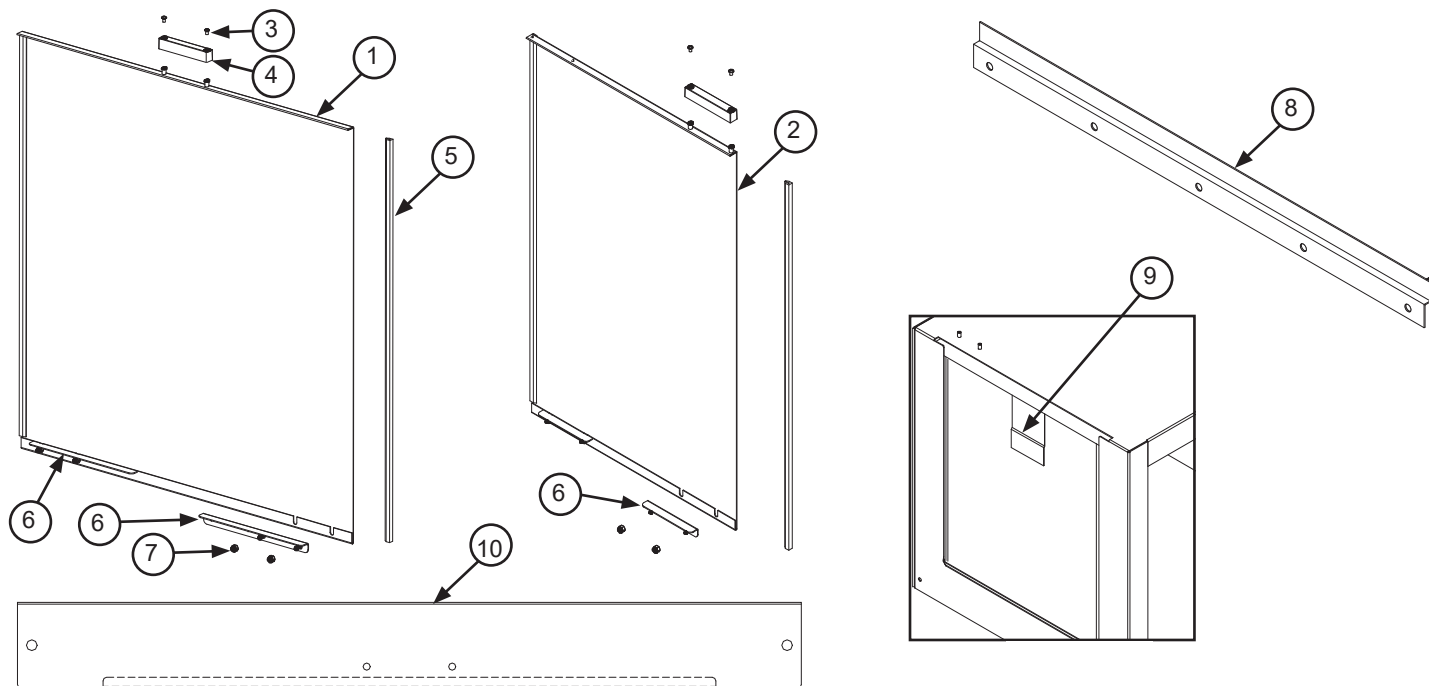

ITEM	QTY	DESCRIPTION	PART NUMBER
1	1 1	Door (Emboss) Door (No Emboss)	05700-031-83-39 05700-003-13-53
2	1 1 1 1	Pre-wash Door, Left-to-Right (Emboss) Pre-wash Door, Left-to-Right (No Emboss) Pre-wash Door, Right-to-Left (Emboss) Pre-wash Door, Right-to-Left (No Emboss)	05700-031-95-05 05700-003-13-42 05700-031-95-07 05700-003-13-40
3	1	Screw, 8-32 x 1/4"	05305-172-09-00
4	1	Door Switch Magnet	05700-111-51-68
5	2	Door Glide	05700-111-70-92
6	3	Door Stop	05700-002-05-46
7	4	Locknut, 10-24 Hex with Nylon Insert	05310-373-01-00
8	1 1	Left Door Guide Right Door Guide	05700-002-32-51 05700-031-76-44
9	1	Door Catch	05700-031-84-80
10	1 1	Door Hood Support Pre-wash Door Hood Support	05700-031-84-13 05700-031-84-14
11	1	Door Stiffener (Not Shown)	05700-031-83-43
12	1	Pre-wash Door Stiffener (Not Shown)	05700-031-83-57
13	1	Handle, Door (Not Shown)	05700-011-82-63
14	1	Handle, Pre-wash Door (Not Shown)	05700-011-80-45

Complete Drive Assembly  
05700-041-67-38

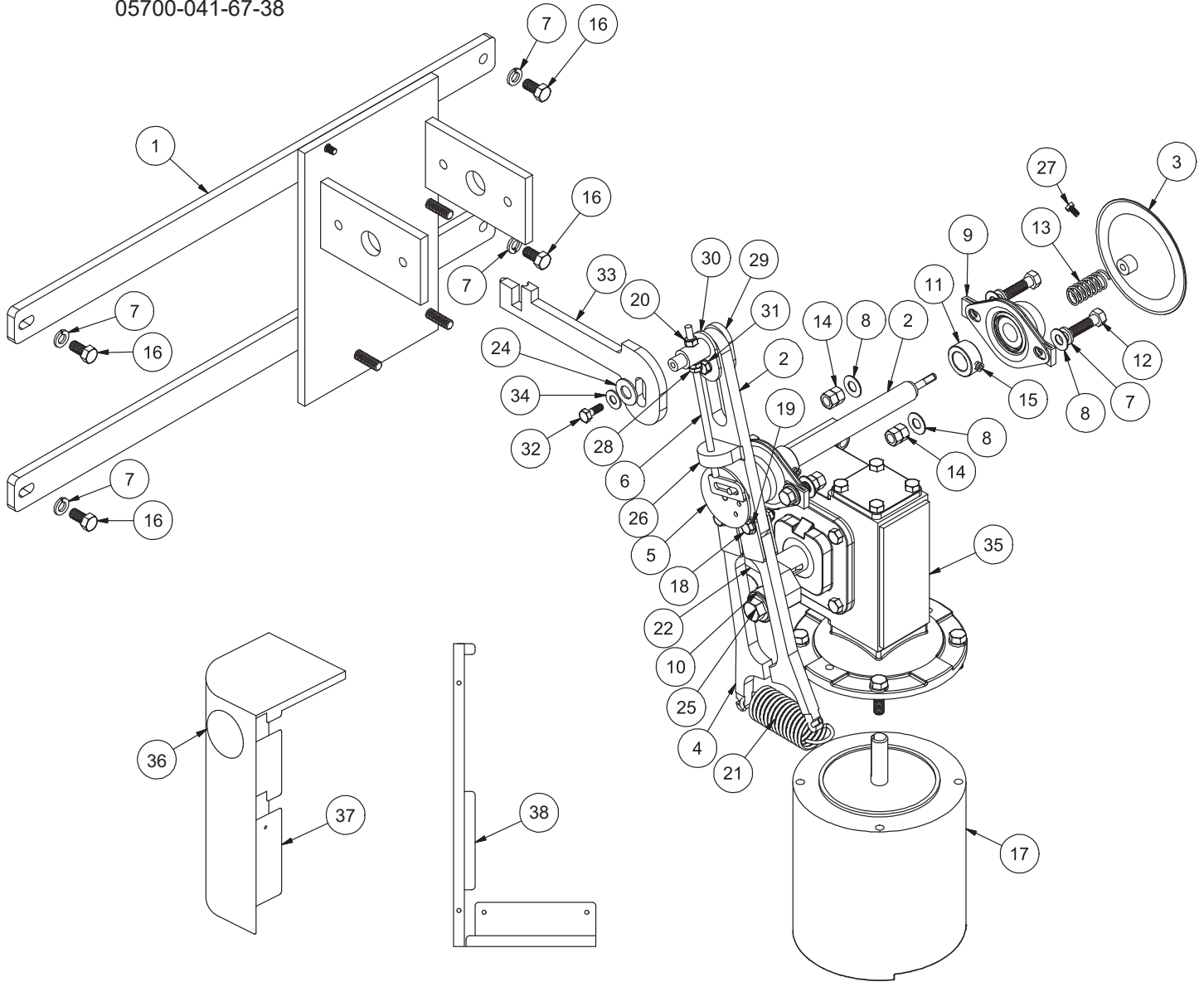

ITEM	QTY	DESCRIPTION	PART NUMBER
1	1	Mounting Bracket Drive Motor	05700-031-73-56
2	1	Drive Plate and Rod	05700-021-67-44
3	1	Adjuster, Handle	05700-021-72-28
4	2	Coupling & Expansion Legs	05700-021-67-50
5	1	Adjuster, Crank Assembly	05700-021-69-95
6	1	Adjuster, Scotch Yoke	05700-021-69-76
7	12	Lockwasher, 3/8"	05311-276-01-00
8	8	Flat Washer, 3/8"	05311-176-01-00
9	2	Block, Pillow	03120-021-71-87

ITEM	QTY	DESCRIPTION	PART NUMBER
10	1	Bearing, Roller	03120-011-71-81
11	2	Collar, Shaft Conveyor Drive	05700-011-89-18
12	4	Bolt, 3/8-16 x 1 3/4"	05306-011-36-94
13	1	Spring, Adjuster	05315-011-71-90
14	12	Nut, Hex, 3/8-16	05310-276-01-00
15	2	Set Screw, 5/16-18 x 1/4"	05305-002-98-39
16	4	Bolt, 3/8-16 x 3/4"	05306-011-71-60
17	1	Drive Motor, 3-phase Machines Drive Motor, 1-phase Machines	06105-121-70-54 06105-021-70-53
18	2	Bolt, 1/4-20 x 1/4"	05305-274-22-00
19	4	Washer, 1/4-20	05311-174-01-00
20	3	Locknut, 1/4-20 Hex with Nylon Insert	05310-374-01-00
21	1	Spring, Drive	05315-011-83-51
22	1	Hub, Drive	05700-011-67-97
23	1	Set Screw, 1/4-20 x 1/2" (Not Shown)	05305-011-71-51
24	3	Flat Washer, 1/2"	05311-011-71-93
25	1	Bolt, 1/2-13 x 1 3/4"	05305-011-71-94
26	1	Plate, Drive Rod	05700-021-67-42
27	1	Bolt, 10-32 x 3/8" Hex Head	05306-011-62-45
28	2	Nut, Hex, 1/4-20	05310-274-01-00
29	1	Socket, Drive	05700-021-67-39
30	1	Plate, Spacer	05700-011-67-58
31	1	Lockwasher, Spring, 1/4"	05311-274-01-00
32	2	Bolt, Hex Head 1/4-20 x 3/4"	05305-004-42-64
33	1	Casting, Pawl Bar Drive Linkage	09515-002-31-78
34	1	Washer, 5/16-18	05311-175-01-00
35	1	Motor, Drive Gear, 50/1	06105-011-87-20
36	1	Decal, Drive Adjuster	09905-003-61-01
37	1	Front Drive Motor Cover	05700-031-69-39
38	1	Rear Drive Motor Cover	05700-002-41-21

Parts are not shown to scale with relation to each other.

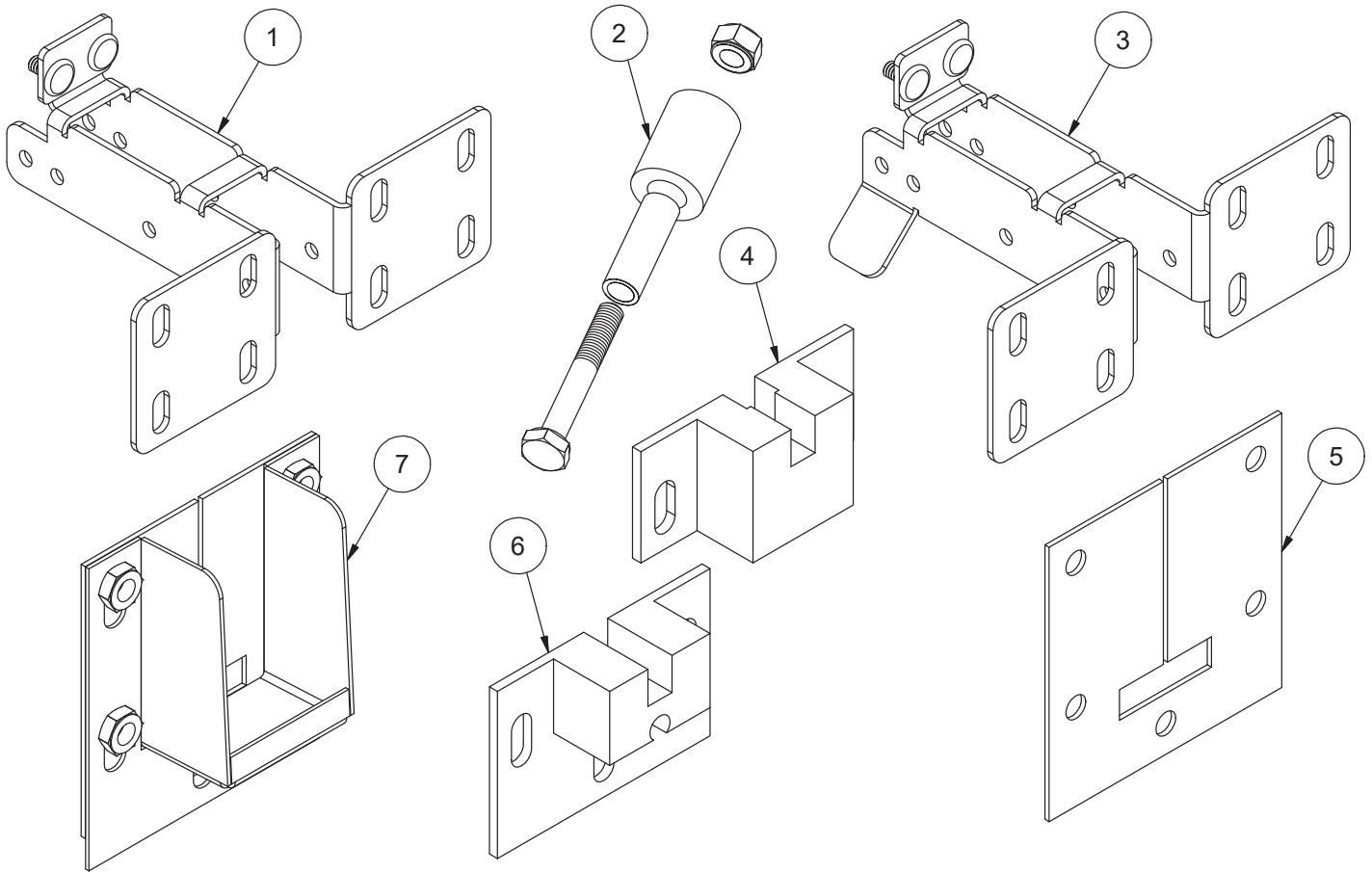

ITEM	QTY	DESCRIPTION	PART NUMBER
1	1	Pawl Bar Bracket (No Tabs)	05700-031-92-36
2	1	Pawl Bar Roller Kit*	06401-003-11-80
3	1	Pawl Bar Bracket (Tabs)	05700-031-84-68
4	1	Top Guide Block	05700-011-69-49
	1	Guide Block Kit*	06401-003-10-15
5	1	Pawl Bar Gutter Gasket	05330-011-68-55
6	1	Bottom Guide Block	05700-011-69-50
7	1	Pawl Bar Gutter Kit*	06401-003-09-95

\* Kit contains part(s) and all hardware.

**NOTICE** When replacing one guide block, the other guide block and the gasket should be replaced as well.

Complete AJ-44 Pawl Bar Assembly with Hardware  
 06401-131-81-00  
 06401-231-81-00 (Prison)

Complete AJ-66 Pawl Bar Assembly with Hardware  
 06401-141-74-64  
 06401-241-74-64 (Prison)

Complete AJ-80 Pawl Bar Assembly with Hardware  
 06401-141-81-06 (L-R)  
 06401-241-81-06 (L-R)  
 06401-341-81-06 (Prison)

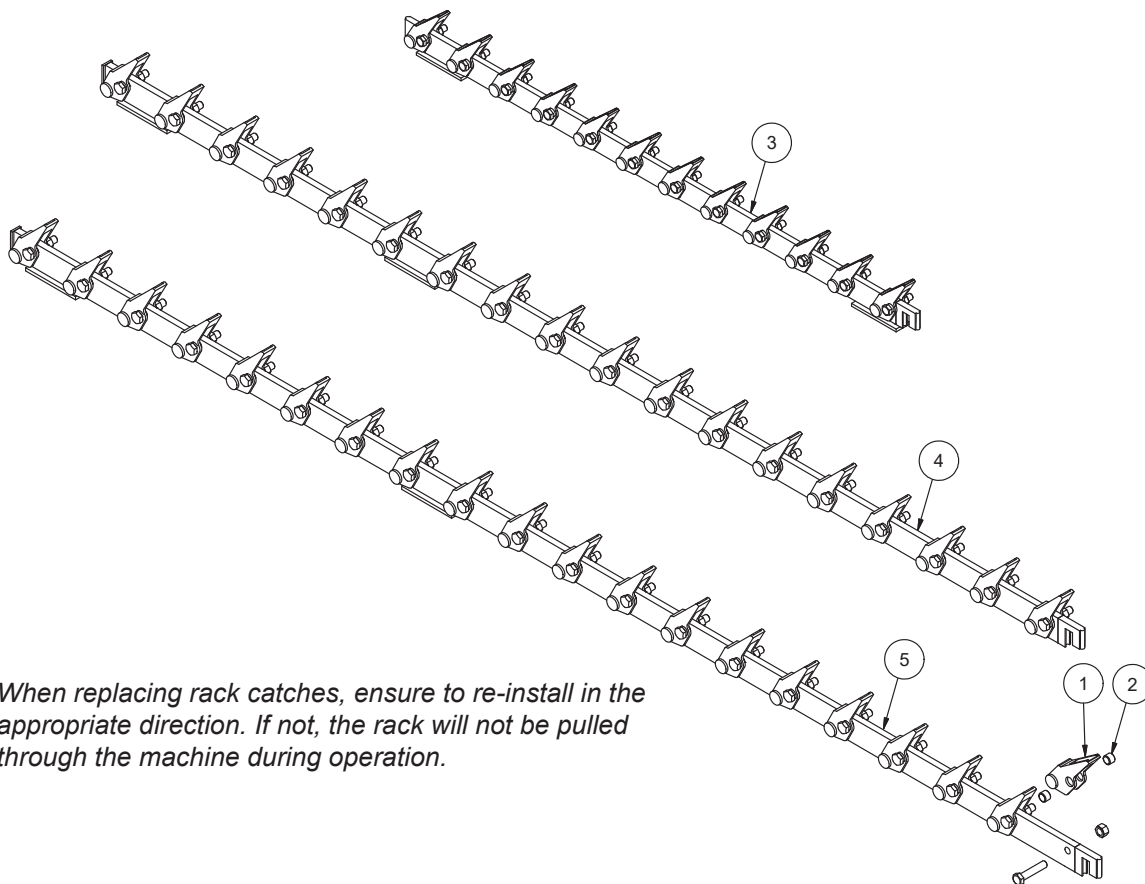

**NOTICE** When replacing rack catches, ensure to re-install in the appropriate direction. If not, the rack will not be pulled through the machine during operation.

ITEM	QTY	DESCRIPTION	PART NUMBER
1	12 on AJ-44 18 on AJ-66 20 on AJ-80	Rack Catch	09515-021-69-00
2	24 on AJ-44 36 on AJ-66 40 on AJ-80	Pawl Bar Spacer	05700-011-71-45
3	1	Pawl Bar (AJ-44)	05700-031-72-77
4	1	Pawl Bar (AJ-66)	05700-031-72-78
5	1	Pawl Bar (AJ-80)	05700-031-74-19

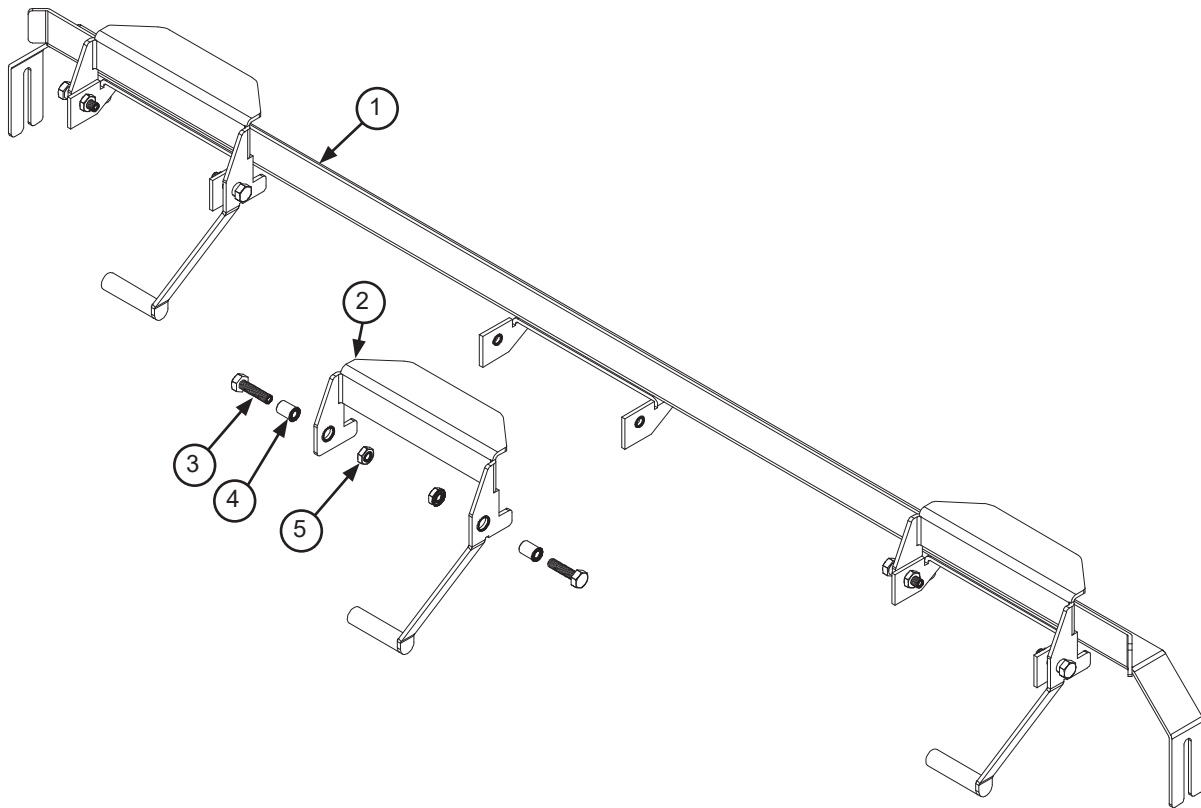

ITEM	QTY	DESCRIPTION	PART NUMBER
1	1 1	Rack Rail Opposite Rack Rail	05700-031-67-59 05700-031-69-48
2	3	Actuator Switch Actuator Switch Replacement Kit <sup>1</sup>	05700-021-72-39 06401-003-10-14
3	6	Bolt, Hex Head 1/4-20 x 3/4"	05305-004-42-64
4	6	Pawl Bar Spacer	05700-011-71-44
5	6	Locknut, 1/4-20 Hex with Nylon Insert	05310-374-01-00

<sup>1</sup>Kit contains the switch, two spacers, and hardware.

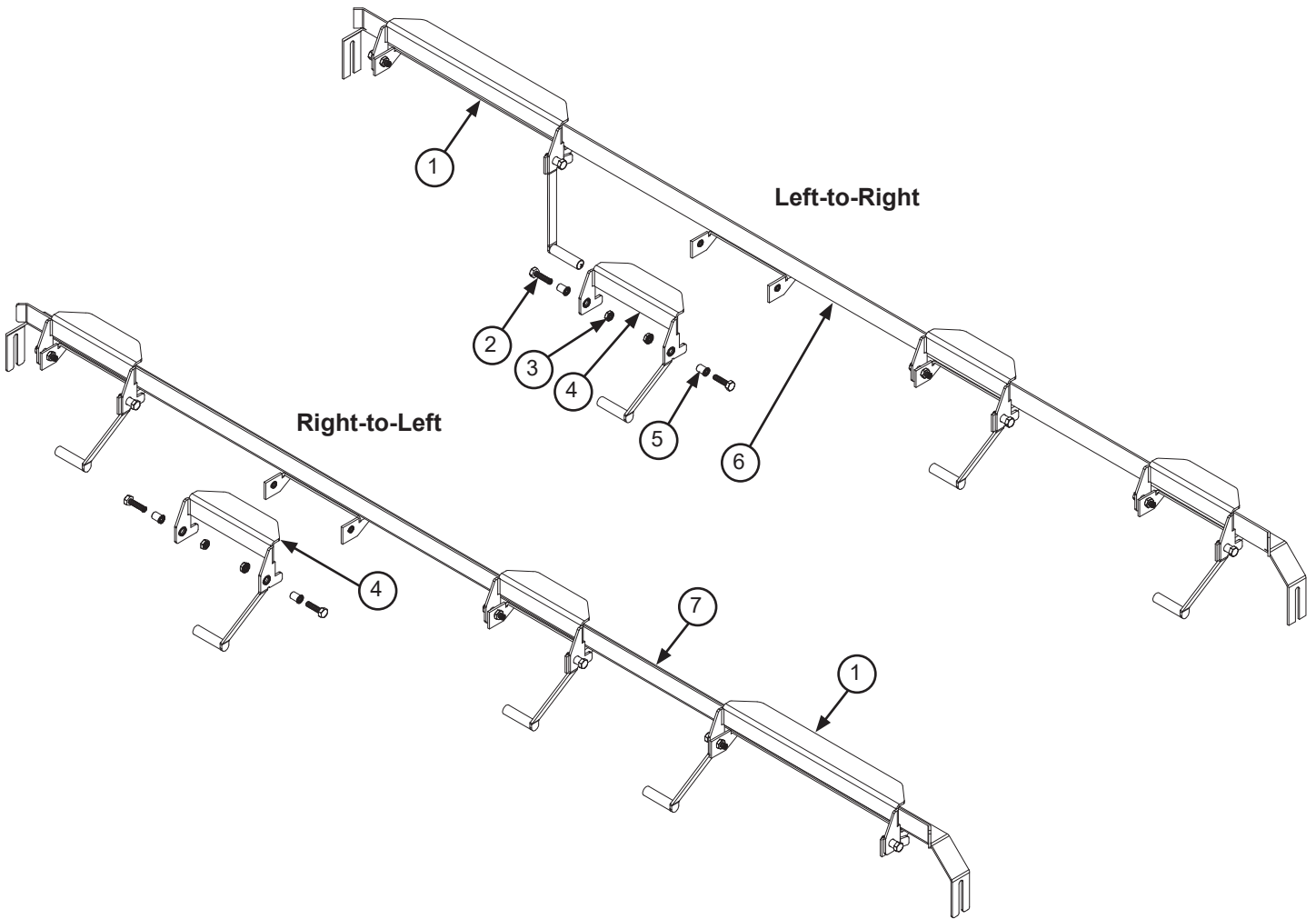



ITEM	QTY	DESCRIPTION	PART NUMBER
1	1	Large Actuator Switch, L-R	05700-021-76-97
	1	Large Actuator Switch Replacement Kit, L-R <sup>1</sup>	06401-003-10-99
		Large Actuator Switch, R-L	05700-002-91-09
		Large Actuator Switch Replacement Kit, R-L <sup>1</sup>	06401-003-10-86
2	8 per rail	Bolt, Hex Head 1/4-20 x 3/4"	05305-004-42-64
3	8 per rail	Locknut, 1/4-20 Hex with Nylon Insert	05310-374-01-00
4	3 per rail	Actuator Switch	05700-021-72-39
		Actuator Switch Replacement Kit <sup>1</sup>	06401-003-10-14
5	8 per rail	Pawl Bar Spacer	05700-011-71-44
6	1	Rack Rail, L-R	05700-031-76-27
		Opposite Rack Rail, L-R	05700-041-71-37
7	1	Rack Rail, R-L	05700-031-76-28
		Opposite Rack Rail, R-L	05700-041-69-54

<sup>1</sup>Kits contain the switch, two spacers, and hardware.

Complete Rinse Fill Motor Assembly  
05700-002-40-25

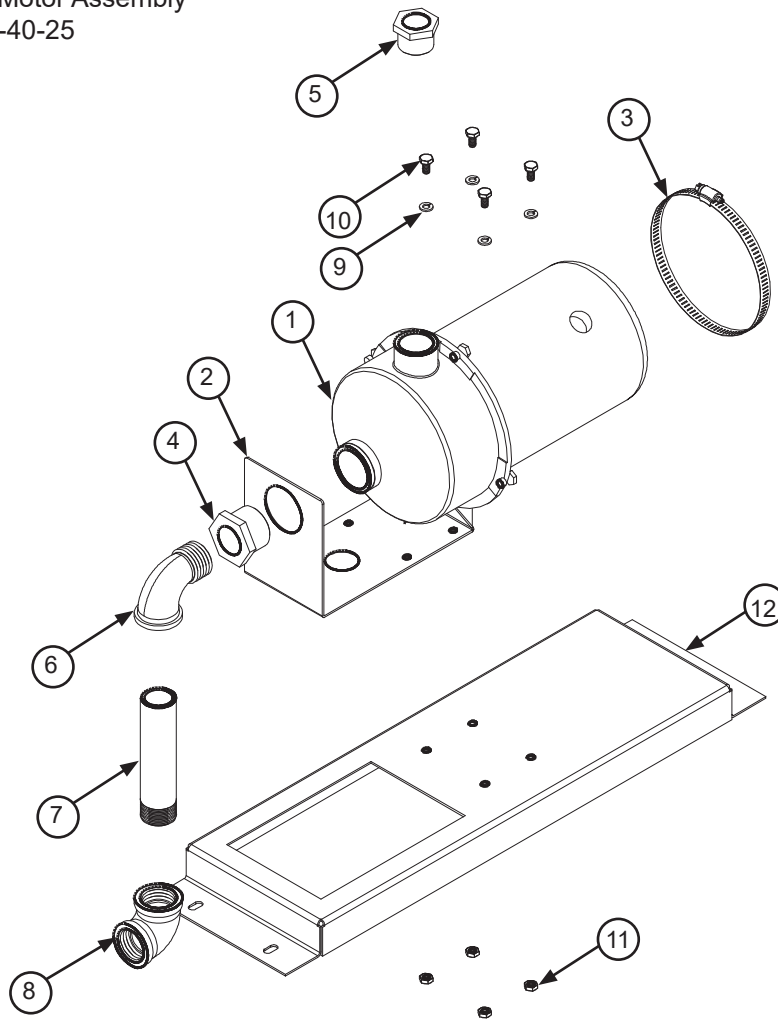

ITEM	QTY	DESCRIPTION	PART NUMBER
1	1	Motor	06105-002-72-71
2	1	Bracket, Pump Mounting	05700-003-17-56
3	1	Clamp, Hose 5 5/8" to 6"	04730-011-34-90
4	1	Reducer Bushing, 1 1/4" to 1"	04730-002-73-62
5	1	Reducer Bushing 1" to 3/4"	04730-011-65-14
6	1	Elbow, 90-Degree, Street Brass, 1"	04730-002-11-99
7	1	Nipple, Brass, 1" x 6"	04730-002-12-00
8	1	Elbow, 90-Degree, Brass, Female	04730-002-12-55
9	4	Lockwasher, 1/4"	05311-274-01-00
10	4	Bolt, 1/4"-20 x 1/2"	05305-274-02-00
11	4	Nut, Hex 1/4-20	05310-274-01-00
12	1	Rinse Motor Mounting Bracket Rinse Motor Mounting Bracket (AJX-66 L-R Only)	05700-002-38-90 05700-002-39-33

Parts are not shown to scale with relation to each other.

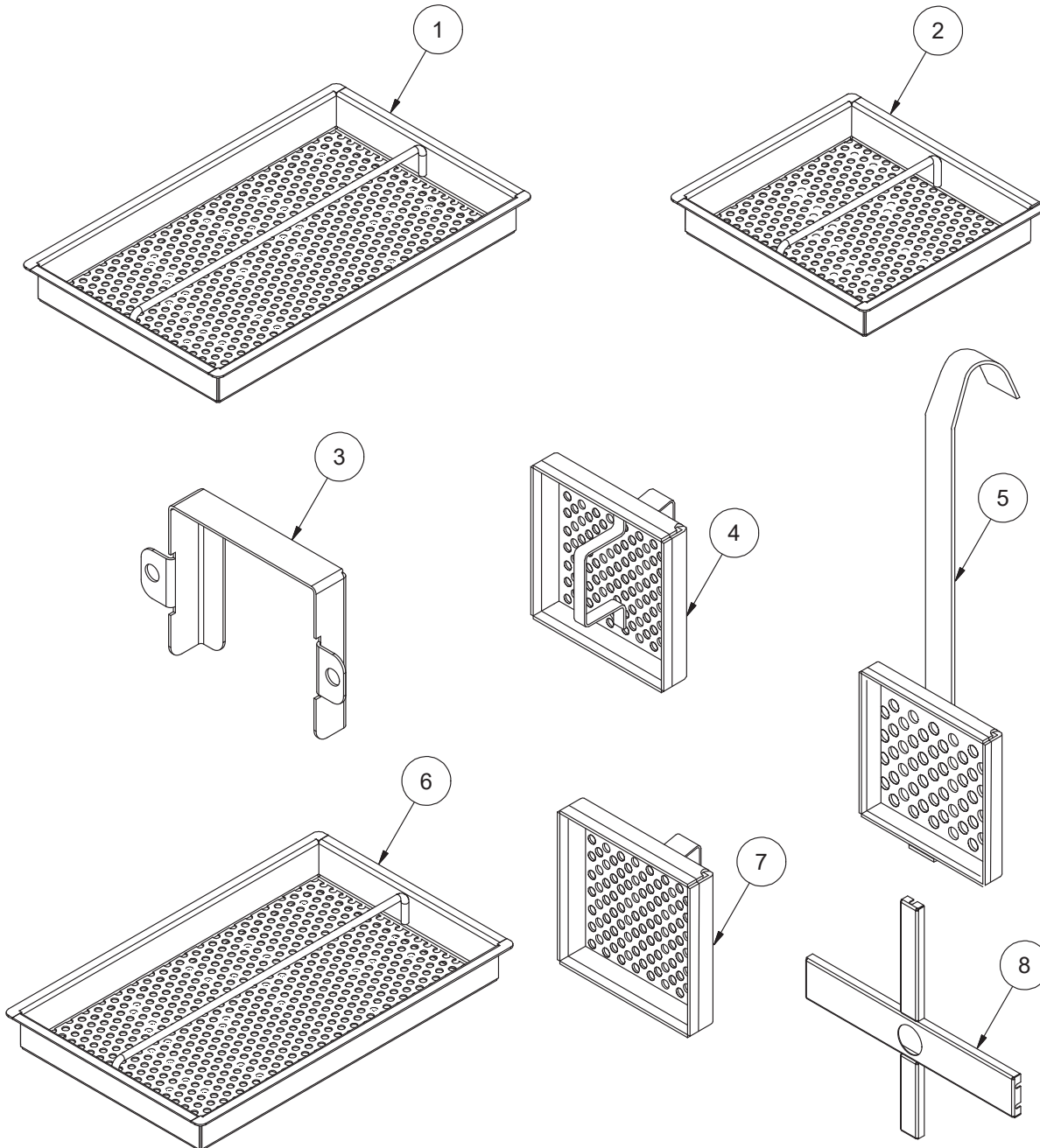

ITEM	QTY	DESCRIPTION	PART NUMBER
1	1	Front Strainer	05700-021-85-10
2	1	Back Strainer	05700-021-85-11
3	1	Overflow Strainer Support	05700-001-96-48
4	1	Drain Guard Strainer	05700-002-09-15
5	1	Wash Intake Strainer	05700-002-51-52
6	1	Tub Strainer	05700-002-03-21
7	1	Screen Strainer with Handle	05700-002-09-04
8	1	Wash Strainer Separator	05700-031-84-38

Parts are not shown to scale with relation to each other.

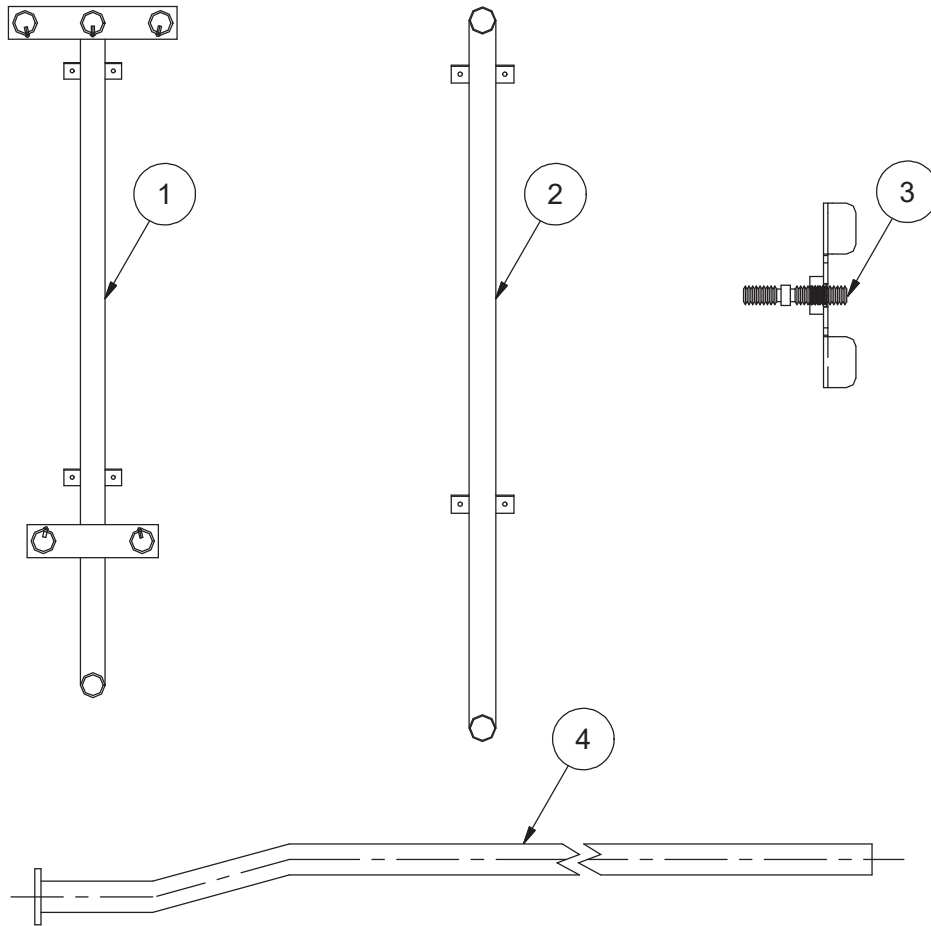

ITEM	QTY	DESCRIPTION	PART NUMBER
1	1	Manifold, Pre-wash (AJ-66) Manifold, Pre-wash (AJ-80)	05700-031-69-70 05700-002-24-94
2	1	Manifold, Wash Washer, Flat, 1/4" (Not Shown) Locknut, 1/4-20 with Nylon Insert (Not Shown)	05700-031-71-13 05311-174-01-00 05310-374-01-00
3	1	Shoulder Bolt Wingnut	05700-002-46-02
4	1	Fill Tube, Wash Fill Tube, Pre-wash (AJ-66/80) Gasket, Fill Tube (Not Shown) Locknut, 1/4-20 with Nylon Insert (Not Shown)	05700-021-71-21 05700-021-74-76 05330-111-42-81 05310-374-01-00

Parts are not shown to scale with relation to each other.

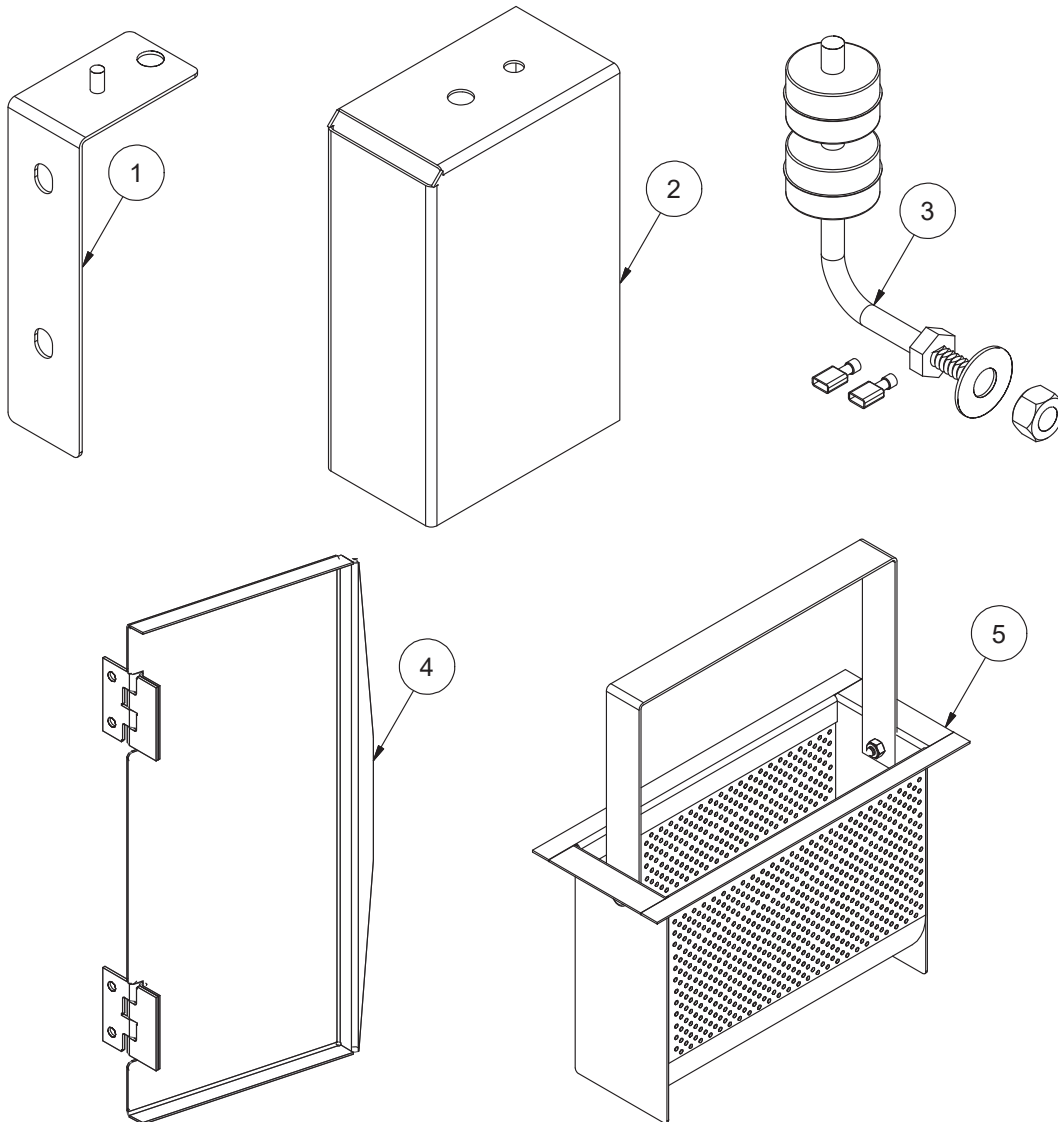

ITEM	QTY	DESCRIPTION	PART NUMBER
1	1	Float Switch Support Bracket Kit*	06401-003-11-77
2	1	Float Switch Cover	05700-021-75-71
3	1	Wash Tank Float Switch Kit* Pre-wash Tank Float Switch Kit*	06401-003-11-75 06401-003-11-76
4	1	Scrap Basket Lid	05700-002-56-55
5	1	Scrap Basket Assembly	06401-011-87-78

\* Kit contains part(s) and all hardware.

**NOTICE** When installing float switch kit, washer goes inside tub and nut goes outside tub.

Parts are not shown to scale with relation to each other.

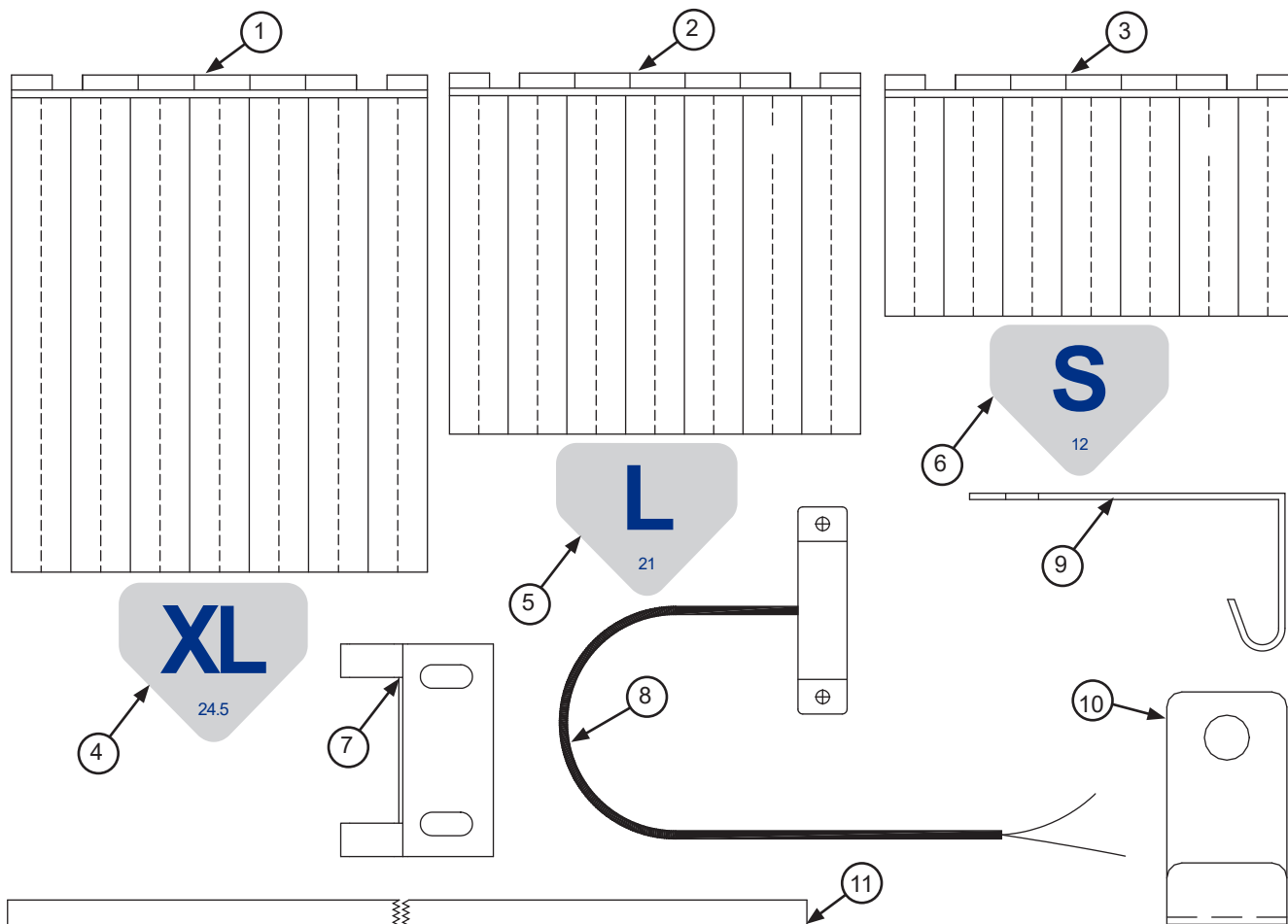

ITEM	QTY	DESCRIPTION	PART NUMBER
1	1	Curtain, XL, 24 1/2" x 20 1/2"	08415-002-47-37
2	1	Curtain, L, 21" x 20 1/2"	08415-131-73-45
3	1	Curtain, S, 12" x 20 1/2"	08415-131-73-44
4	1	Decal, XL Curtain	09905-004-38-08
5	1	Decal, L Curtain	09905-004-38-07
6	1	Decal, S Curtain	09905-004-38-05
7	1	Limit Switch Bracket	05700-021-71-18
8	1	Conveyor Switch Kit*	06401-003-11-79
9	1	Middle Curtain Hook	05700-011-72-65
10	1	Curtain Hook	05700-011-83-54
11	1	Curtain Rod	05700-003-77-52
12	1	Curtain, XL, Side-loader (Not Shown)	08415-003-84-88
13	1	Curtain Rod, Side-loader (Not Shown)	05700-003-84-57

\* Kit contains the switch, a terminal, and a wire nut. Cut the cord on the Conveyor Switch to length in the field and install the terminal there.

Parts are not shown to scale with relation to each other.

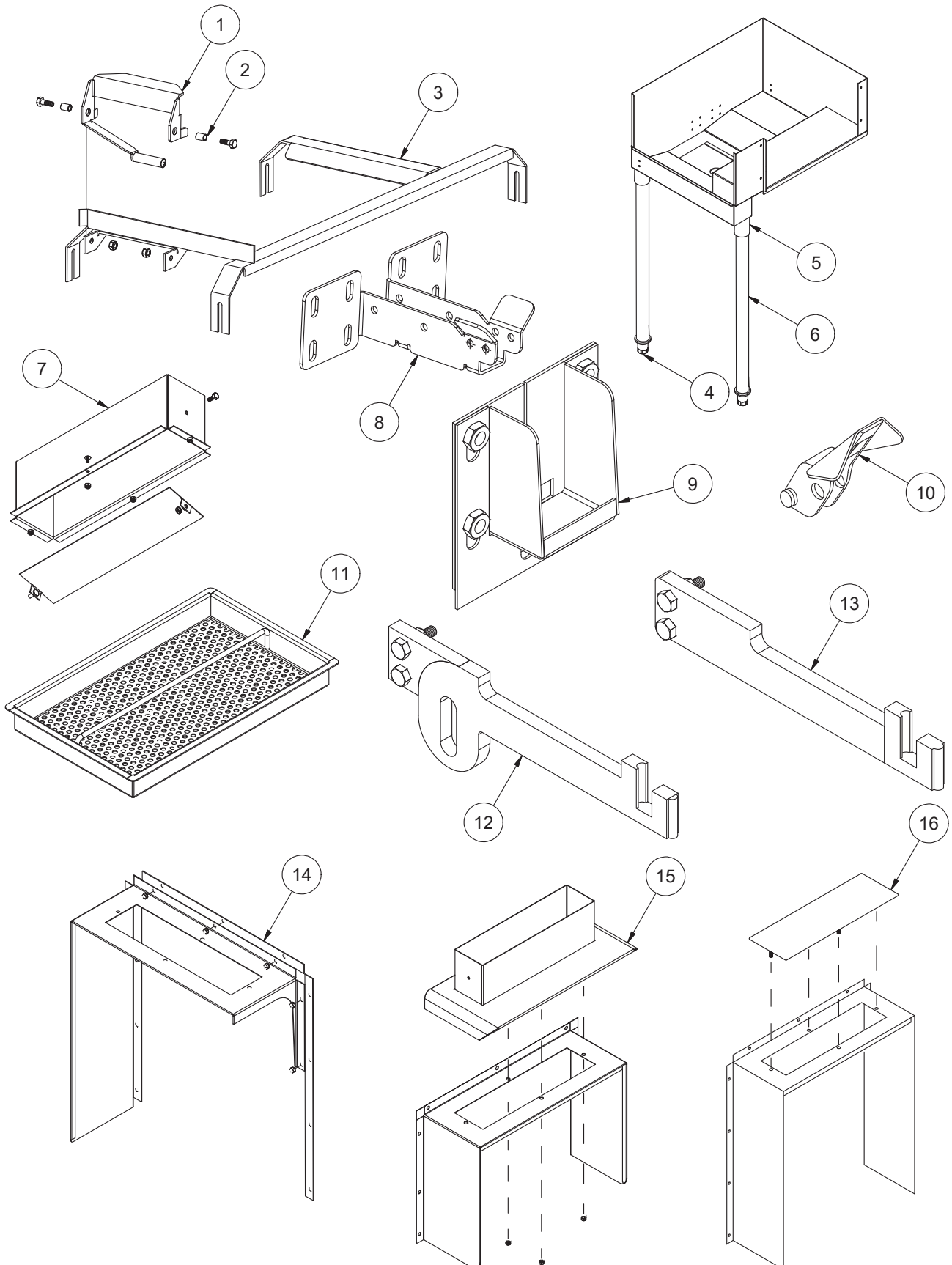

ITEM	QTY	DESCRIPTION	PART NUMBER
1	1	Actuator Switch, Side-loader Actuator Switch Kit*	05700-002-91-12 06401-003-10-64
2	1	Pawl Bar Spacer	05700-011-71-44
3	1	Track, Side-loader (L-R), 23" Track, Side-loader (R-L), 23" Track, Side-loader (L-R), 30" Track, Side-loader(R-L), 30"	05700-031-78-98 05700-031-95-20 05700-003-04-57 05700-003-04-58
4	1	Adjustable Foot, Side-loader	05340-108-01-03
5	1	Leg Socket Kit*	06401-003-09-79
6	1	Leg Support Kit*	06401-003-09-80
7	1	Vent Cowl Assembly for Hooded Side-loader	05700-003-15-66
8	1	Pawl Bar Roller Bracket	05700-031-77-94
9	1	Pawl Bar Gutter Kit*	06401-003-09-95
10	1	Rack Catch	05700-021-86-79
11	1	Front Strainer, Side-loader	05700-021-85-10
12	1	Drive Linkage Kit (L-R)*	06401-003-11-59
13	1	Drive Linkage Kit (R-L)*	06401-003-11-60
14	1	Vent Scoop Option Assembly	05700-002-04-08
15	1	Vent Cowl Cover Kit*	06401-003-10-16
16	1	Vent Cowl Option Assembly for Hooded Side-loader	05700-003-15-66

\* Kit contains part(s) and all hardware.



Parts are not shown to scale with relation to each other.

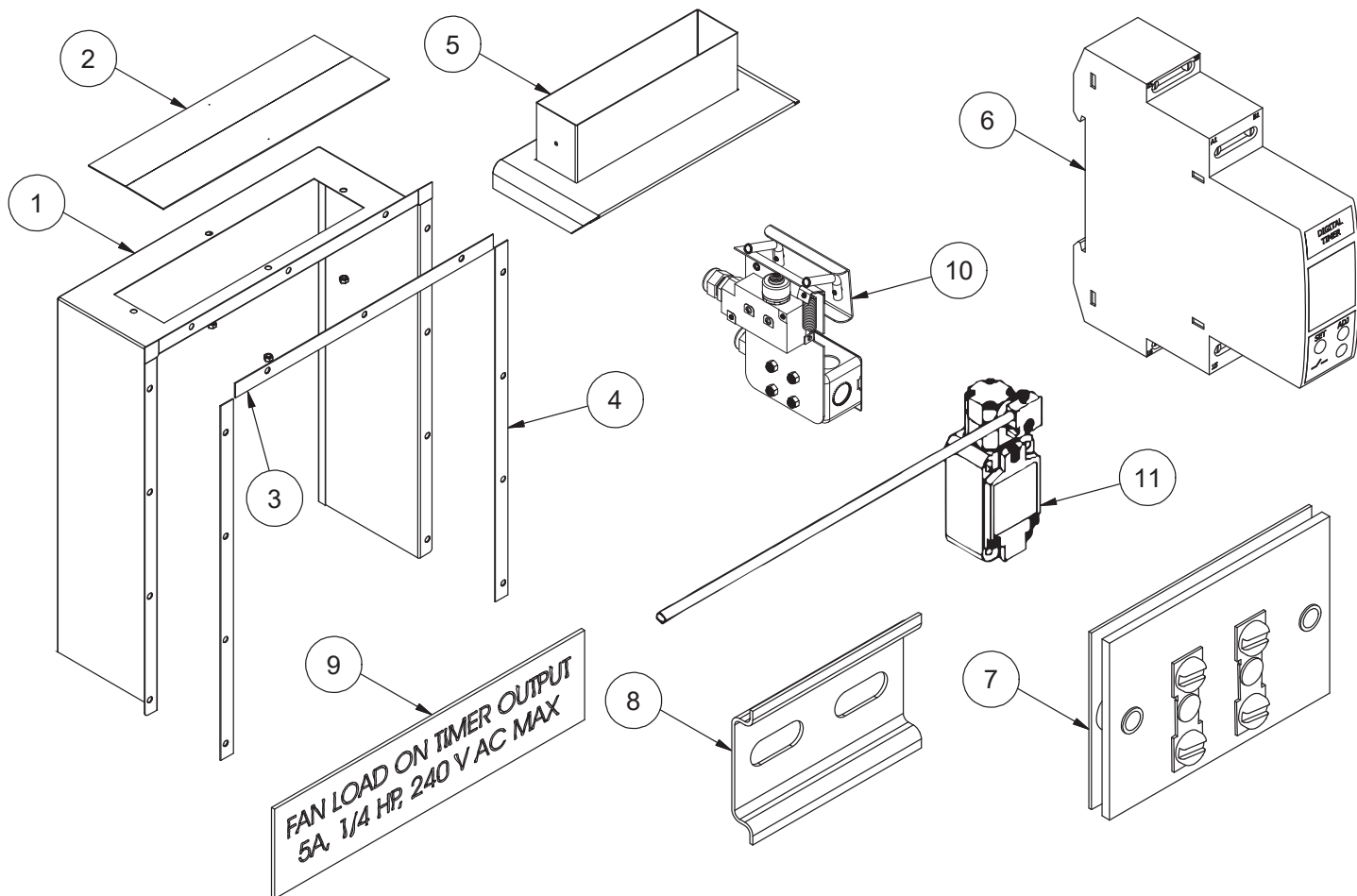

ITEM	QTY	DESCRIPTION	PART NUMBER
1	1	Vent Cowl	05700-041-86-94
2	1	Vent Cowl Cover Vent Cowl Cover Replacement Kit*	05700-011-74-67 06401-003-10-16
3	1	Gasket, Top Vent Cowl	05330-031-83-47
4	1	Gasket, Side Vent Cowl	05330-031-83-48
5	1	Vent Scoop Option	05700-002-04-08
6	1	Delay Timer, Exhaust Fan	05945-004-22-78
7	1	Terminal Board, Exhaust Fan	05940-011-84-41
8	1	Din Rail, Exhaust Fan	05700-002-36-09
9	1	Decal, Exhaust Fan Load	09905-003-32-20
10	1	Striker Plate Limit Switch Complete Assembly	05700-002-62-94
11	1	Whisker Plate Limit Switch Complete Assembly	05700-002-06-83

\* Kit contains part(s) and all hardware.

Exhaust Fan Kit  
05700-003-14-59

Parts are not shown to scale with relation to each other.

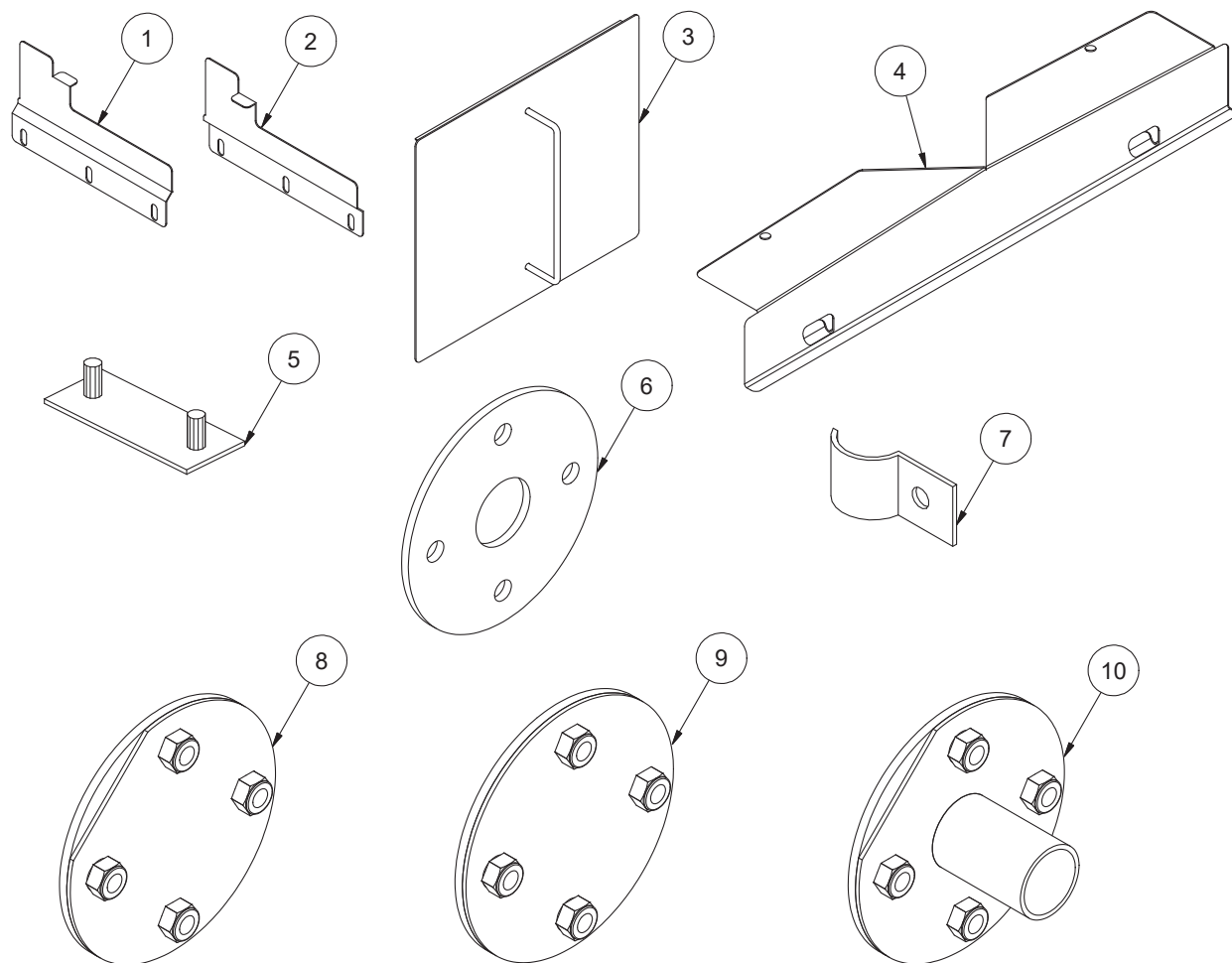

ITEM	QTY	DESCRIPTION	PART NUMBER
1	1	Plate, Left Water Directional	05700-021-79-27
2	1	Plate, Right Water Directional	05700-021-79-23
3	1	Run-off Sheet	05700-021-71-39
4	1	Splash Shield	05700-031-85-16
5	1	Hole Direction Plate Kit*	06401-003-10-00
6	1	Rinse Drain Plate Gasket	05330-011-72-27
7	1	Pipe Clamp	05700-000-35-05
8	1	Rinse Drain Plate Kit*	06401-003-10-07
9	1	Rinse Drain Plug Kit*	06401-003-10-06
10	1	Rinse Drain Weldment Kit*	06401-003-10-05

\* Kit contains part(s) and all hardware.

The Go Box is a kit of the most-needed parts to successfully complete a repair in the first call, 90% or more of the time.

Go Box Kit  
06401-002-14-99

QTY	DESCRIPTION	PART NUMBER
1	Contactora, Drive Motor	05945-111-68-38
1	Contactora, Wash Heater, 3-phase, 3-pole	05945-002-24-70
1	Contactora, Wash Heater, 1-phase, 4-pole	05945-111-68-37
2	End-cap, Final Rinse Arm	05700-011-35-92
1	Float Switch, Dual, Wash & Pre-wash	06680-121-70-71
1	Gasket, Pawl Bar Gutter	05330-011-68-55
1	Gauge, Pressure	06685-111-88-34
6	Glide, Door Edge	05700-111-70-92
2	Magnet, Door Reed Switch	05930-111-51-68
2	O-ring, Pre-wash Manifold	05330-400-12-08
2	O-ring, Wash Manifold	05330-011-74-56
1	Overload, Drive Motor	05945-111-68-39
1	Overload, Wash Motor	05945-111-68-40
1	Relay, 120 V, 3 PDT	05945-111-72-51
1	Relay, 120 V, 50/60 Hz, 3A Control	05945-111-35-19
1	Repair Kit, Vacuum Breaker, 3/4"	04820-001-60-57
4	Roller, Pawl Bar	05700-011-68-16
1	Kit, Seal for Wash and Pre-wash Pump	05330-011-71-98
2	Solenoid Valve, Fill & Rinse	04810-100-53-00
2	Switch, Power	05930-011-49-55
2	Switch, Reed, Actuator (NC)	05930-111-68-44
1	Switch, Reed, Door (NO)	05930-111-68-86
1	Thermometer, 48" Capillary	06685-111-68-48
1	Thermometer, 96" Capillary	06685-111-68-49
2	Thermostat, Wash High-Limit	05930-121-71-36
2	Thermostat, Wash Regulating	05930-121-67-72
1	Transformer, 150 V	05950-011-68-35
1	Valve, Ball 1 1/2"	04820-111-71-46

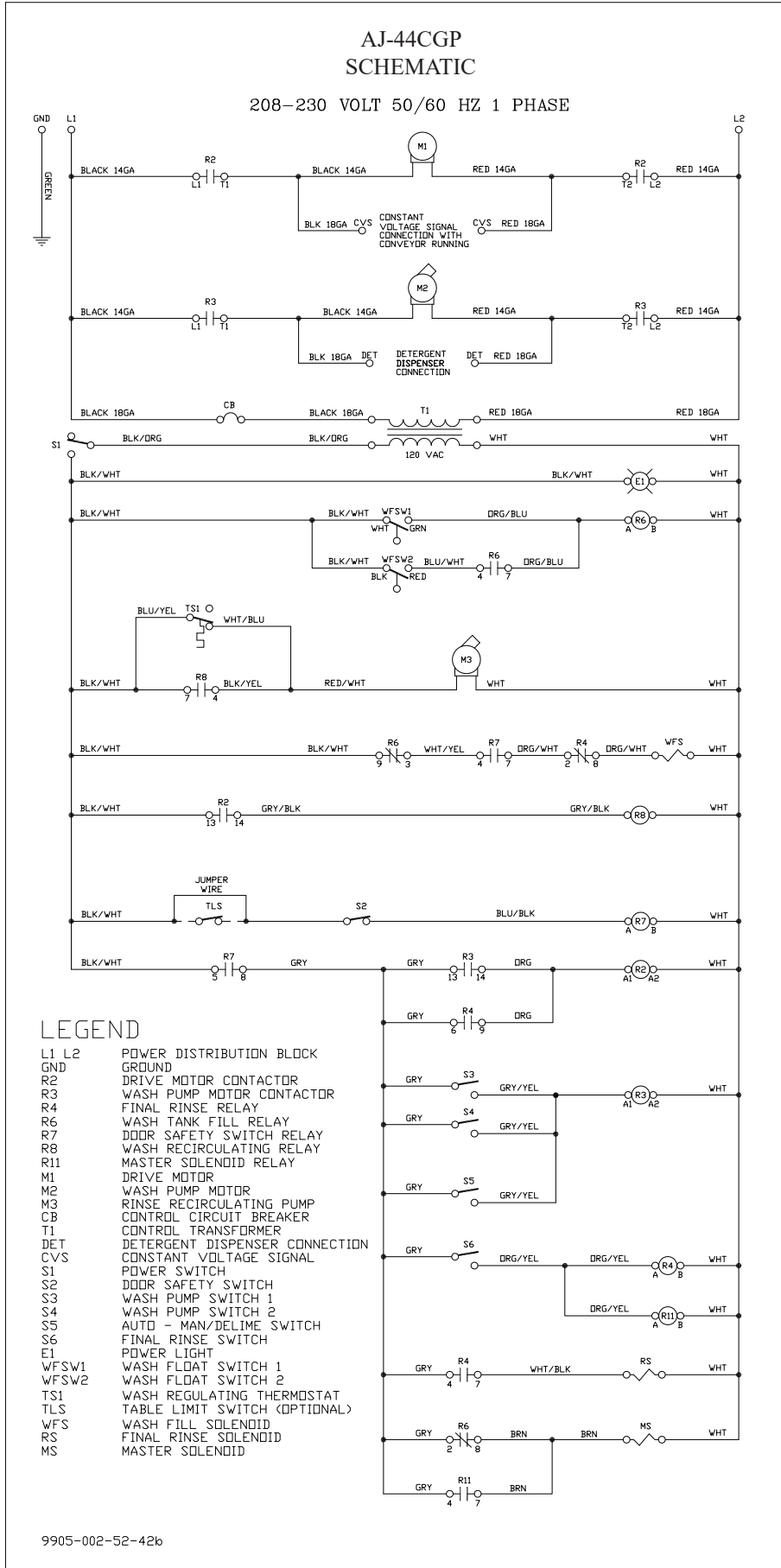

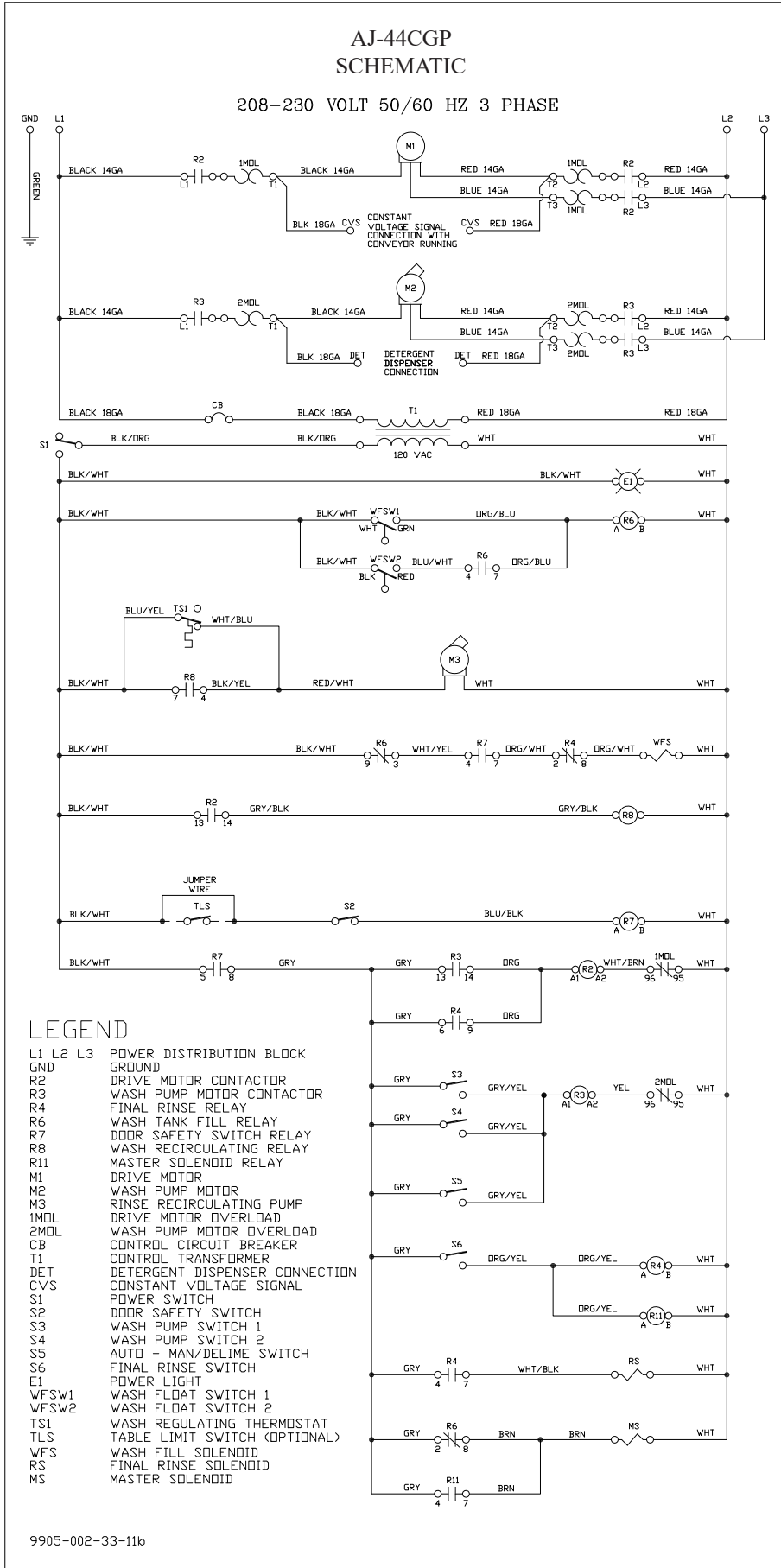

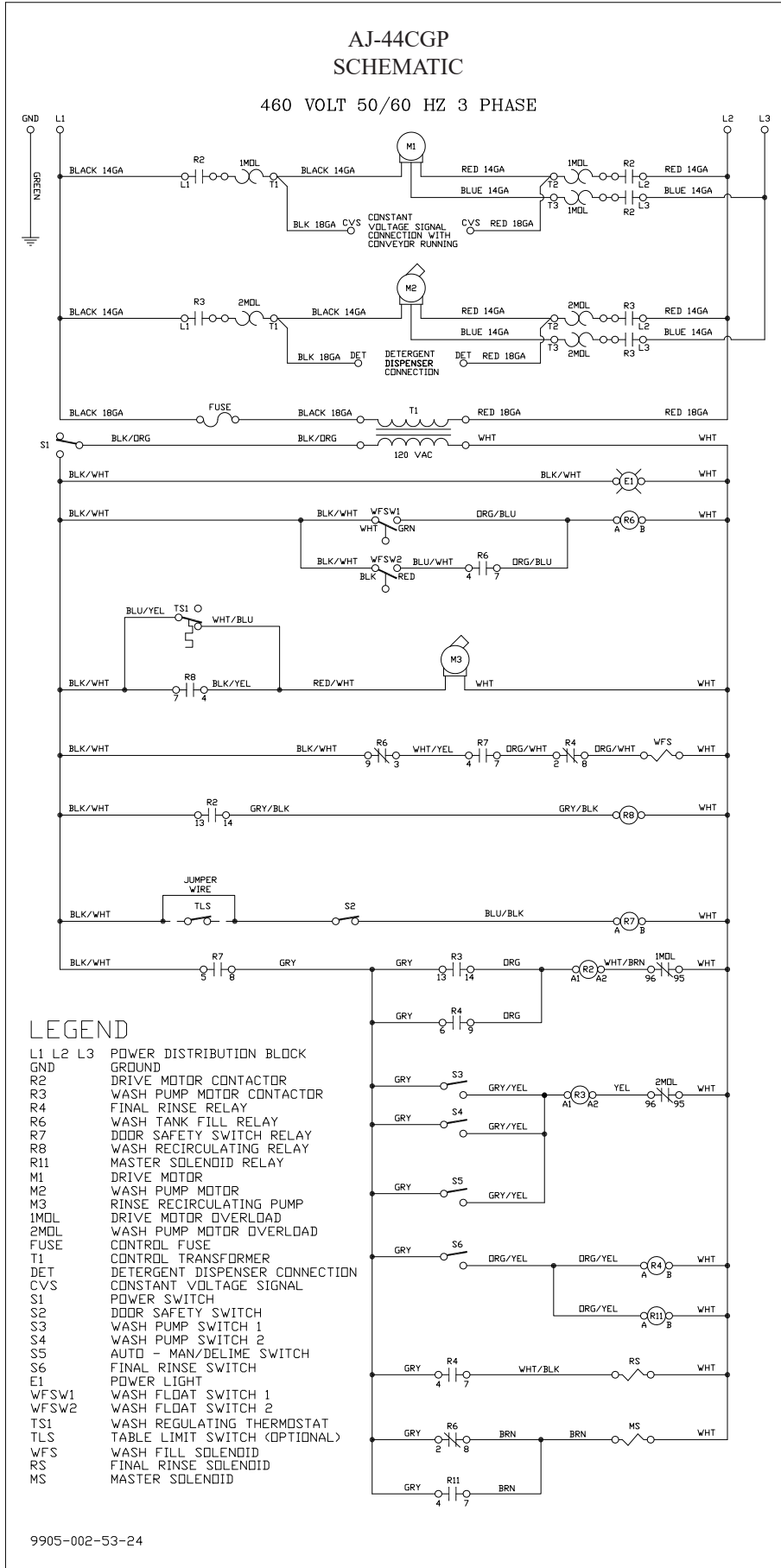

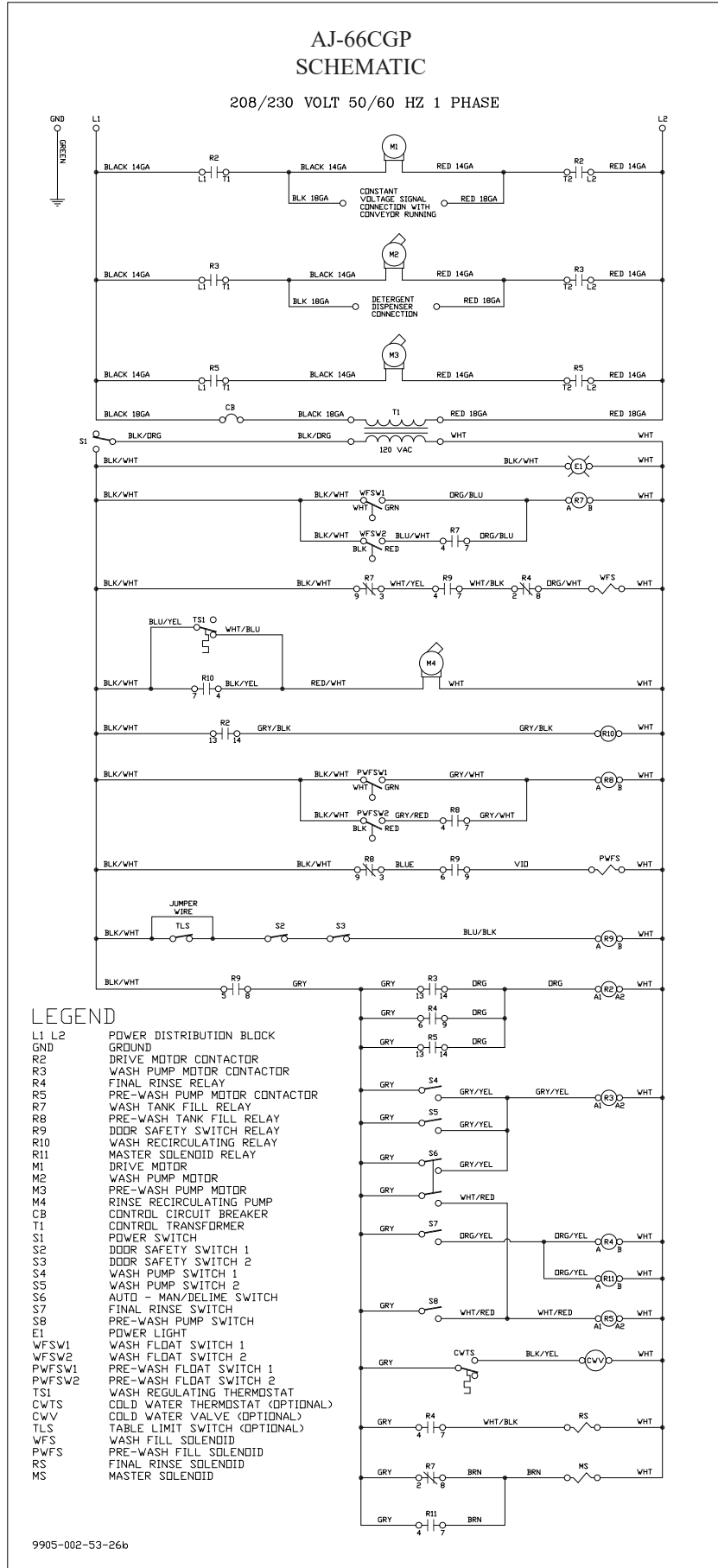

**AJ-66CGP  
SCHEMATIC**

208/230 VOLT 50/60 HZ 3 PHASE

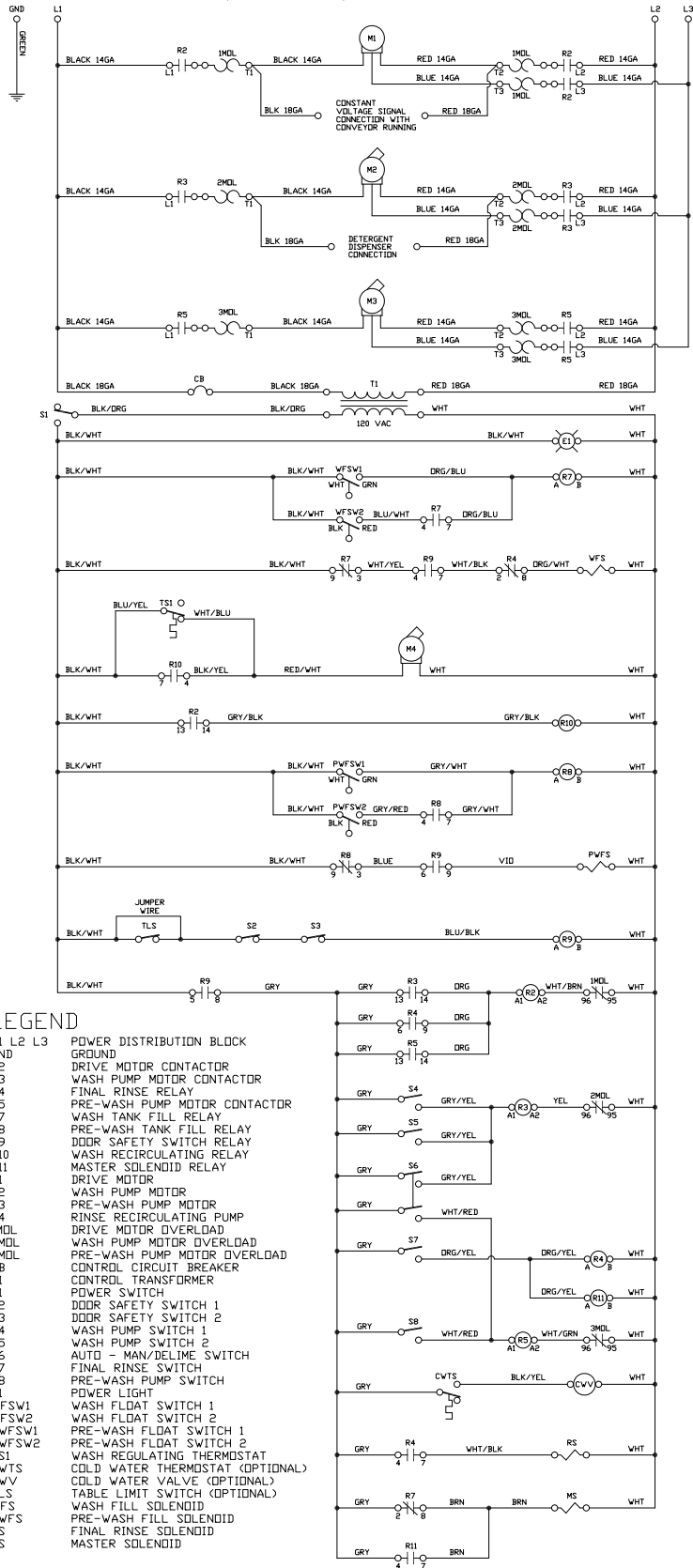

**LEGEND**

- L1 L2 L3 POWER DISTRIBUTION BLOCK
- GND GROUND
- R2 DRIVE MOTOR CONTACTOR
- R3 WASH PUMP MOTOR CONTACTOR
- R4 FINAL RINSE RELAY
- R5 PRE-WASH PUMP MOTOR CONTACTOR
- R7 WASH TANK FILL RELAY
- R8 PRE-WASH TANK FILL RELAY
- R9 DOOR SAFETY SWITCH RELAY
- R10 WASH RECIRCULATING RELAY
- R11 MASTER SOLENOID RELAY
- M1 DRIVE MOTOR
- M2 WASH PUMP MOTOR
- M3 PRE-WASH PUMP MOTOR
- M4 RINSE RECIRCULATING PUMP
- 1MOL DRIVE MOTOR OVERLOAD
- 2MOL WASH PUMP MOTOR OVERLOAD
- 3MOL PRE-WASH PUMP MOTOR OVERLOAD
- CB CONTROL CIRCUIT BREAKER
- T1 CONTROL TRANSFORMER
- S1 POWER SWITCH
- S2 DOOR SAFETY SWITCH 1
- S3 DOOR SAFETY SWITCH 2
- S4 WASH PUMP SWITCH 1
- S5 WASH PUMP SWITCH 2
- S6 AUTO - MAN/DELTIME SWITCH
- S7 FINAL RINSE SWITCH
- S8 PRE-WASH PUMP SWITCH
- E1 POWER LIGHT
- WFSW1 WASH FLDAT SWITCH 1
- WFSW2 WASH FLDAT SWITCH 2
- PWFSW1 PRE-WASH FLDAT SWITCH 1
- PWFSW2 PRE-WASH FLDAT SWITCH 2
- TS1 WASH REGULATING THERMOSTAT (OPTIONAL)
- CWTS COLD WATER THERMOSTAT (OPTIONAL)
- CWV COLD WATER VALVE (OPTIONAL)
- TLS TABLE LIMIT SWITCH (OPTIONAL)
- WFS WASH FILL SOLENOID (OPTIONAL)
- PWFS PRE-WASH FILL SOLENOID
- RS FINAL RINSE SOLENOID
- MS MASTER SOLENOID

9905-002-33-61d



**AJ-66CGP  
SCHEMATIC**

460 VOLT 50/60 HZ 3 PHASE

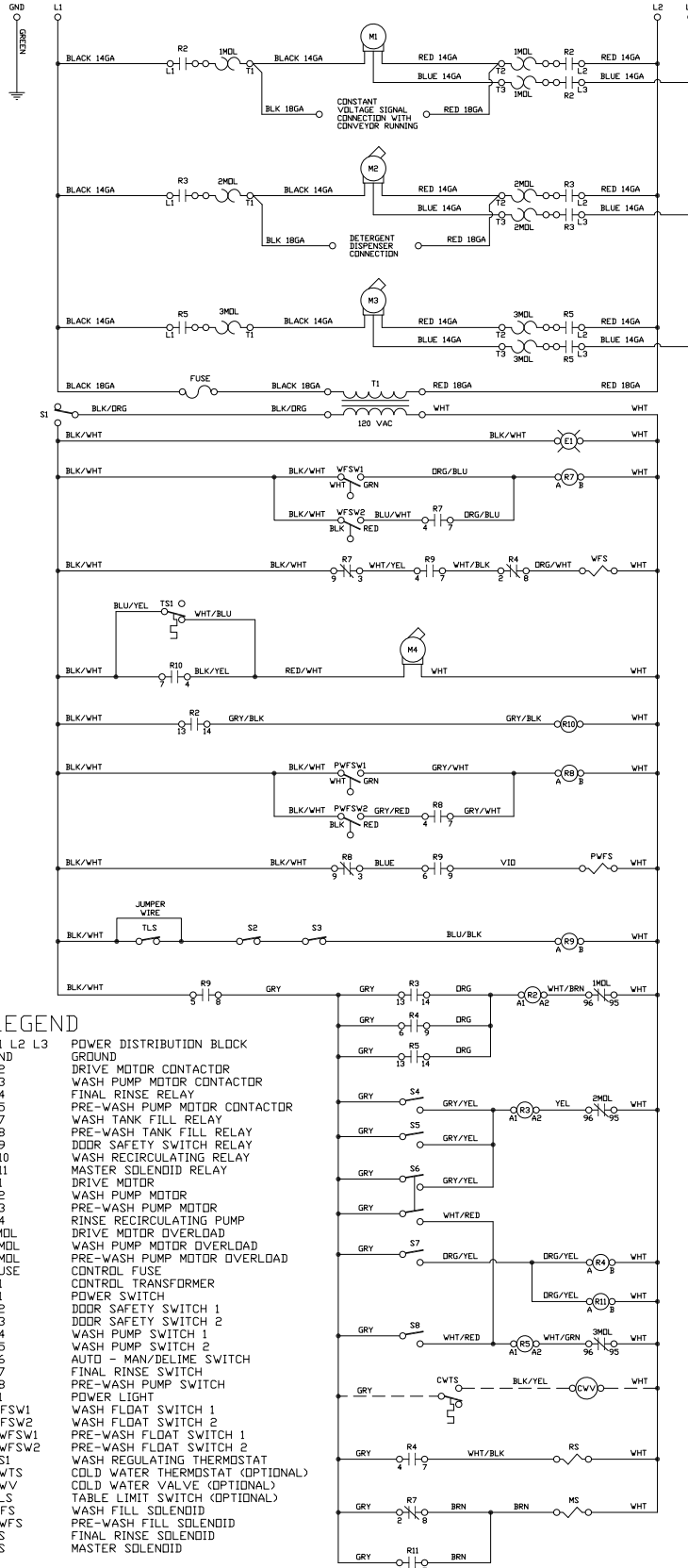

**LEGEND**

- L1 L2 L3 POWER DISTRIBUTION BLOCK
- GND GROUND
- R2 DRIVE MOTOR CONTACTOR
- R3 WASH PUMP MOTOR CONTACTOR
- R4 FINAL RINSE RELAY
- R5 PRE-WASH PUMP MOTOR CONTACTOR
- R7 WASH TANK FILL RELAY
- R8 PRE-WASH TANK FILL RELAY
- R9 DOOR SAFETY SWITCH RELAY
- R10 WASH RECIRCULATING RELAY
- R11 MASTER SOLENOID RELAY
- M1 DRIVE MOTOR
- M2 WASH PUMP MOTOR
- M3 PRE-WASH PUMP MOTOR
- M4 RINSE RECIRCULATING PUMP
- 1MDL DRIVE MOTOR OVERLOAD
- 2MDL WASH PUMP MOTOR OVERLOAD
- 3MDL PRE-WASH PUMP MOTOR OVERLOAD
- FUSE CONTROL FUSE
- T1 CONTROL TRANSFORMER
- S1 POWER SWITCH
- S2 DOOR SAFETY SWITCH 1
- S3 DOOR SAFETY SWITCH 2
- S4 WASH PUMP SWITCH 1
- S5 WASH PUMP SWITCH 2
- S6 AUTO - MAN/DELTIME SWITCH
- S7 FINAL RINSE SWITCH
- S8 PRE-WASH PUMP SWITCH
- E1 POWER LIGHT
- WFSW1 WASH FLDAT SWITCH 1
- WFSW2 WASH FLDAT SWITCH 2
- PWFSW1 PRE-WASH FLDAT SWITCH 1
- PWFSW2 PRE-WASH FLDAT SWITCH 2
- TS1 WASH REGULATING THERMOSTAT (OPTIONAL)
- CWTS COLD WATER THERMOSTAT (OPTIONAL)
- CWV COLD WATER VALVE (OPTIONAL)
- TLS TABLE LIMIT SWITCH (OPTIONAL)
- WFS WASH FILL SOLENOID (OPTIONAL)
- PWFS PRE-WASH FILL SOLENOID
- RS FINAL RINSE SOLENOID
- MS MASTER SOLENOID

9905-002-53-25b

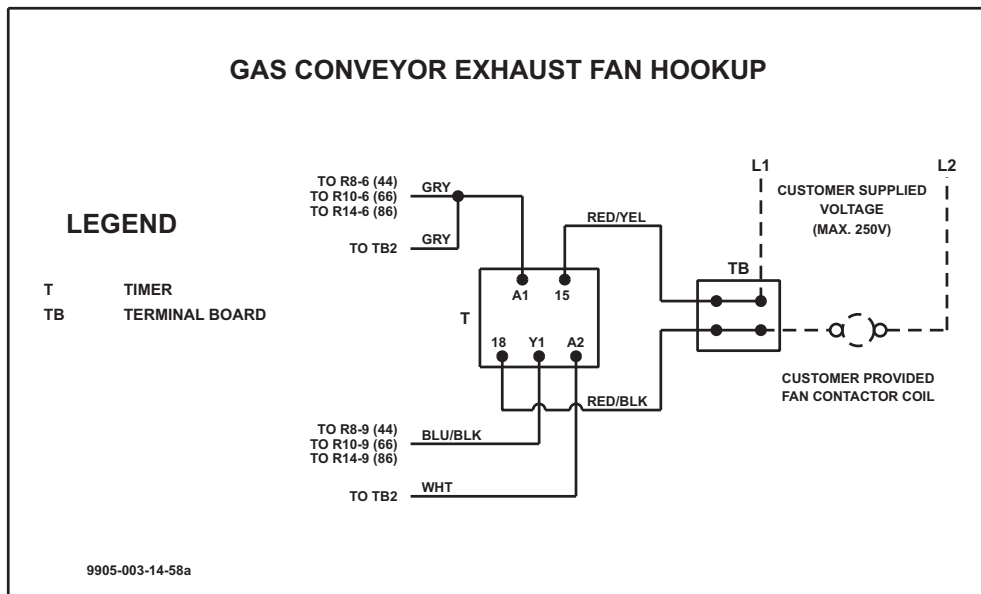

# CONVEYOR SIDE LOADER

44, 54, 64 INCH CONVEYORS

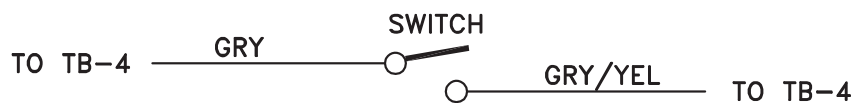

ALL CONVEYORS WITH PRE-WASH

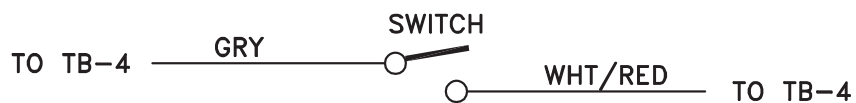

9905-002-56-84a



Jackson WWS, Inc. • 6209 N. US Hwy 25E • Gray, KY 40734 USA  
1.888.800.5672 • [www.jacksonwws.com](http://www.jacksonwws.com)