

# Avenger® HT-E

Project \_\_\_\_\_  
 Item \_\_\_\_\_  
 Quantity \_\_\_\_\_  
 CSI Section 11400 \_\_\_\_\_  
 Approval \_\_\_\_\_  
 Date \_\_\_\_\_

Avenger® HT-E

## Models

Avenger® HT-E



### Standard Features

- Automatic fill
- Sensor Touch™ start
- Built-in booster heater with Sani-Sure™ feature ensures proper sanitation
- Labyrinth type door design
- Automatic pumped drain for floor and wall drain installations
- Stainless steel wash pump
- Digital and electromechanical components
- Manual override for extended wash and deliming
- Simplified controls allow easy access for operation and service
- Door switch
- One (1) each peg and combination rack included
- Built-in chemical pumps and priming switches

### Mandatory Specs

Specify voltage \_\_\_\_\_

### Options

- 1/2" Pressure Regulator
- Water Hammer Arrestor
- Back Panel
- Drain Quench System
- Scale Prevention System (SPS)
- Replacement Cartridge for SPS
- Tie Down

### Accessories

- 36-Compartment Rack
  - 4-1/8" tall (105 mm)
  - 5-5/8" tall (143 mm)
  - 7" tall (178 mm)
- Combination Rack
- Peg Rack
- Machine Stand
  - 6" (152 mm) high
  - 18" (457 mm) high

## Specifications

- Uses 0.73 gallons (2.8 liters) of water per rack
- Uses 19.2 gallons (72 liters) of water per hour
- Cleans 26 racks per hour
- One minute, forty-seven second automatic cycle
- Powerful 1 hp wash pump motor
- Fresh water rinse eliminates wash water contamination
- Air insulated between body and stainless steel housing
- Durable stainless steel construction
- Unique timer allows the machine to be customized for extended cycle times

### Notes:

A vent hood is not recommended above the Jackson Avenger® HT-E as it does not produce excessive vapors. *Always check with the local building code to know what type of ventilation is required for commercial dish machine installations in your area.*

Normal operation of the Avenger® HT-E generates steam that may escape from the door. Materials such as wood laminate, veneers, etc. are unsuitable for use in areas exposed to dishwasher steam and detergents. Stainless steel or other moisture-resistant shields are recommended for surfaces adjacent to Avenger® HT-E sides and top.



Intertek



Intertek





Warewashing Systems

Avenger® HT-E

**LEGEND:**

- A - Water Inlet - 3/4" Male Garden Hose Connection (Connect to a true 1/2" ID water line)
- B - Electrical Connection
- C - Drain Connection - 6' coiled drain hose. Shipped inside machine. Must be installed no more than 24" AFF

All dimensions from floor can be increased 1" with adjustable feet supplied.

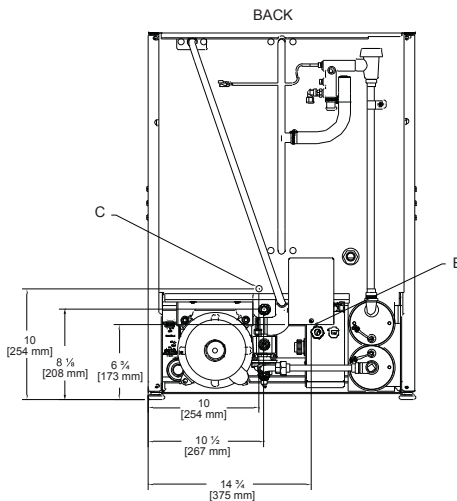
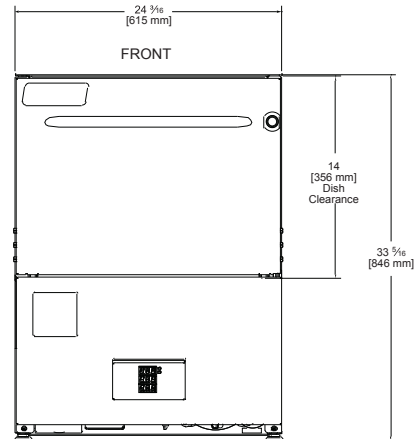
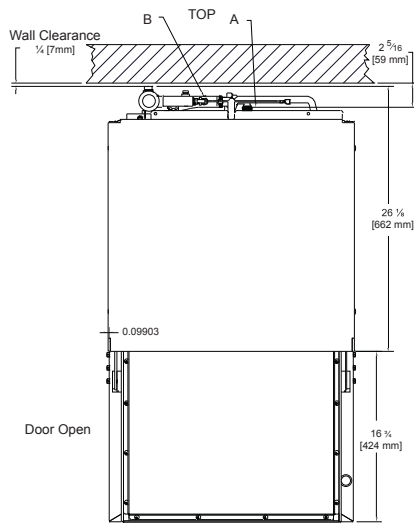

MODEL NO.	MACHINE DIMENSIONS				WALL CLEARANCE	SHIPPING INFORMATION					
	INSIDE CLEARANCE HEIGHT	INSIDE CLEARANCE WIDTH	INSIDE CLEARANCE DEPTH	DOOR OPEN DEPTH		WEIGHT	CLASS	CUBE	HEIGHT	WIDTH	DEPTH
Avenger® HT-E	14-1/4" (368 mm)	20" (508 mm)	20" (508 mm)	42" (1067 mm)	1/4" (6 mm)	255 lbs (116 kg)	85	20.09 cu. ft.	43.5" (1105 mm)	28" (712 mm)	28.5" (724 mm)

APPROXIMATE TOTAL AMP LOADS	
208/60/1	36.8
230/60/1	39.8
480/60/3	11.3

OPERATING CAPACITY	
Racks per Hour	26
Dishes per Hour	650
Glasses per Hour	936

WASH PUMP MOTOR	
Wash Pump	1 hp

OPERATING CYCLE	
Wash Cycle (seconds)	75
Drain Time (seconds)	08
Rinse Cycle (seconds)	09
Total Cycle (seconds)	107

WATER REQUIREMENTS	
Incoming Water Temperature	110° F (43.3° C)
Gallons per Rack	0.73 gal (2.8 L)
Gallons per Hour	19.2 gal (72 L)
Flow Pressure (PSI)	10 - 15
Waterline Size (IPS)	1/2"
Drainline Size (OD)	1-3/8"

OPERATING TEMPERATURES	
Wash	155° F (68.3° C)
Rinse	180° F (82.2° C)

HOW TO SPECIFY: Avenger® HT-E

**Jackson WWS, Inc.**

Shipping Address: 6209 North U.S. Highway 25E, Gray, KY 40734  
 Mailing Address: P.O. Box 1060, Barbourville, KY 40906  
 Telephone: 888-800-5672 • Fax: 606-523-1799  
 Email: info@jacksonwws.com  
 07610-004-04-42 [03/02/17]

www.jacksonwws.com

We reserve the right to change specifications in this bulletin without incurring any obligation for equipment previously or subsequently sold.