

Project _____
 Item _____
 Quantity _____
 CSI Section 11400
 Approval _____
 Date _____

Models

CREW® 66



*Product image shown with optional Door Accent Panels

Standard Features

- 19-3/4" (502 mm) clearance
- WISR® Cleaning System
- Double-wall insulated door retains heat, keeping wash water hot & generating less heat in the dish room
- Self-cleaning wash arms
- Fully automatic, including auto-fill
- Digital temperature readout
- Adjustable vent cowl collars
- 24V DC control circuit
- Exclusive EnergyGuard™ controls
- Self-draining SS wash pump
- Vent fan control
- Internally-operated drain lever
- PLC controls
- Large front access for ease of maintenance
- Pressure regulator
- Conveyor drive motor comes standard on the output end of machine; must be specified at time of order for input end placement
- Rainbow Rinse™ with arched rinse arm (*patent pending*)
- Stainless steel strainer pans
- Splash shields
- Stainless steel frame and legs
- Exhaust vent fan control
- 18kW wash tank heater
- Front dress panel
- Adjustable bullet feet

Mandatory Specs

Specify:

- Electric
 Steam

Specify Voltage _____

Specify Sanitizing Method:

- High Temperature
 Chemical Sanitizing

Specify Direction of Operation:

- Left to Right
 Right to Left

Options

- Onboard Booster
 40° F (22.2° C) Rise
 70° F (38.9° C) Rise
 Single Point Connection with Onboard Booster (*3 phase only*)
 Steam Booster Heater
 23" (584 mm) Unhooded Side Loader
 30" (762 mm) Unhooded Side Loader
 Strike Plate Table Limit Switch
 Flanged Feet
 Door Accent Panels (*must be specified at time of order*)
 Prison Package

Accessories

- 36-Compartment Rack
 4-1/8" tall (104 mm)
 5 - 5/8" tall (143 mm)
 7" tall (178 mm)
 Combination Rack
 Peg Rack
 Sheet Pan Rack
 Drain Quench System
 Scaltrol
 Water Hammer Arrestor

Specifications

Uses 0.35 gallons of water (1.32 liters) per rack

Cleans 223 racks per hour

18" (457 mm) wash section with a 14" (356 mm) separation between wash and rinse

22" (559 mm) pre-wash section has 3 upper and 1 lower pre-wash arms

Durable stainless steel construction



Intertek



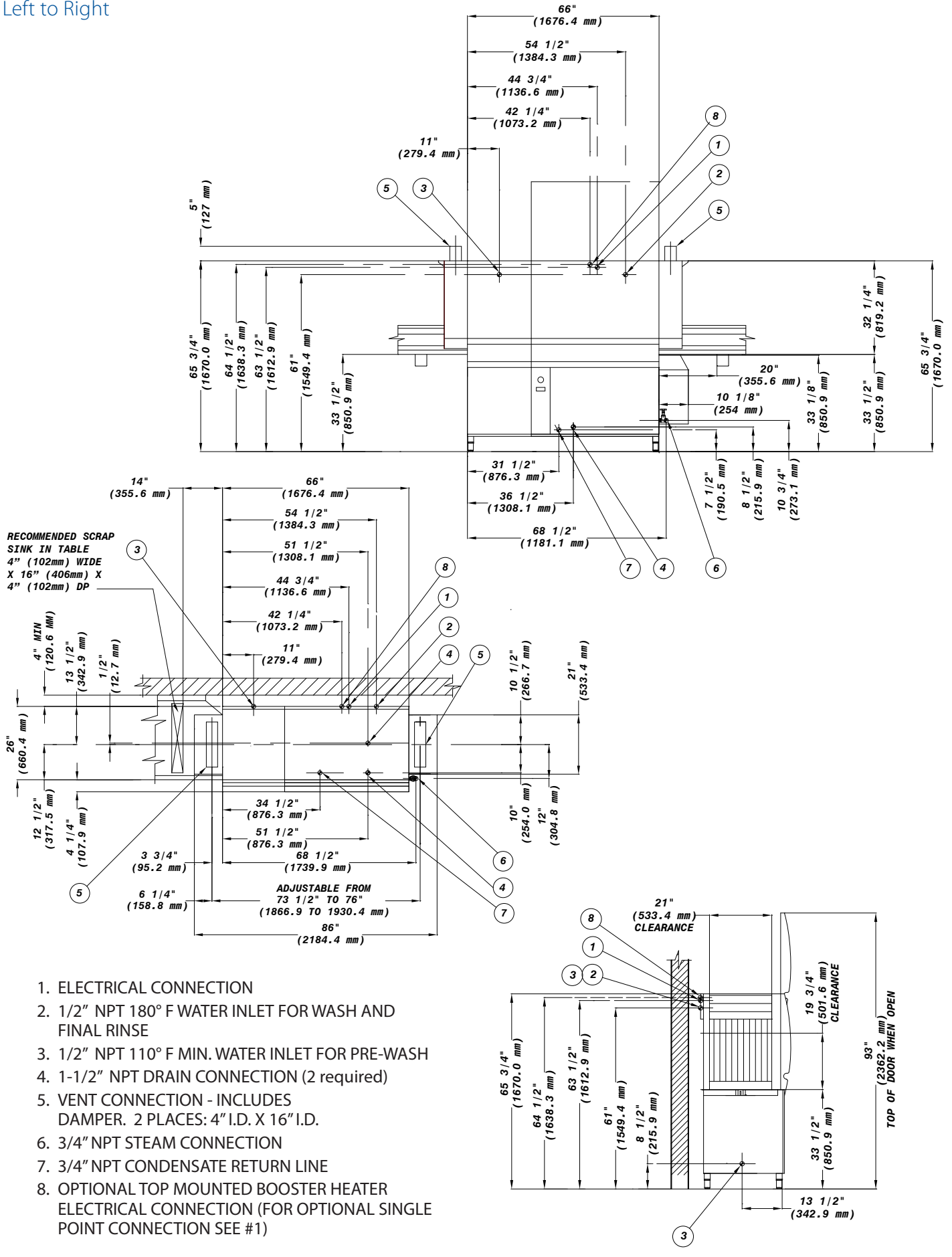

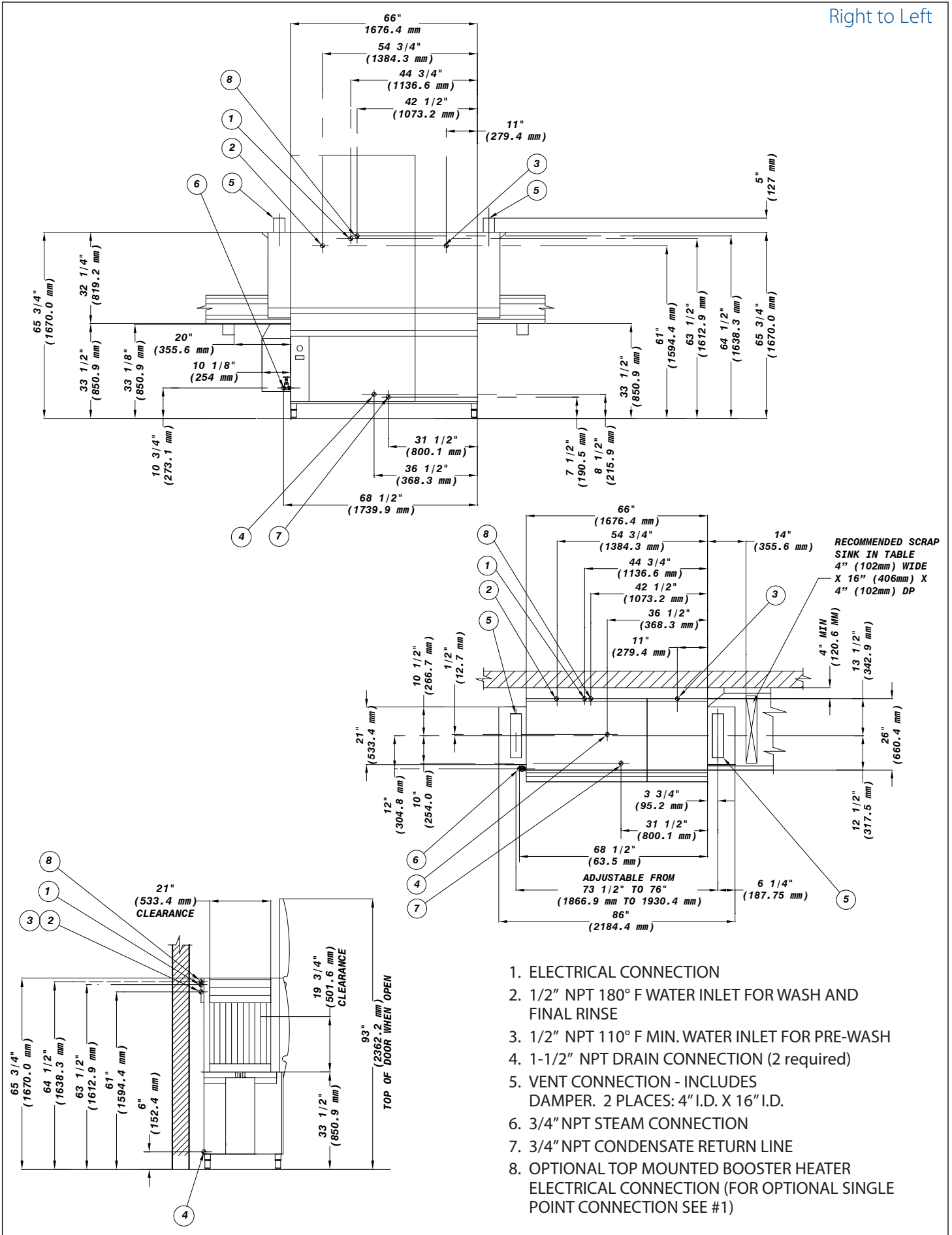

1. ELECTRICAL CONNECTION
2. 1/2" NPT 180° F WATER INLET FOR WASH AND FINAL RINSE
3. 1/2" NPT 110° F MIN. WATER INLET FOR PRE-WASH
4. 1-1/2" NPT DRAIN CONNECTION (2 required)
5. VENT CONNECTION - INCLUDES DAMPER. 2 PLACES: 4" I.D. X 16" I.D.
6. 3/4" NPT STEAM CONNECTION
7. 3/4" NPT CONDENSATE RETURN LINE
8. OPTIONAL TOP MOUNTED BOOSTER HEATER ELECTRICAL CONNECTION (FOR OPTIONAL SINGLE POINT CONNECTION SEE #1)

RECOMMENDED TABLE FABRICATION

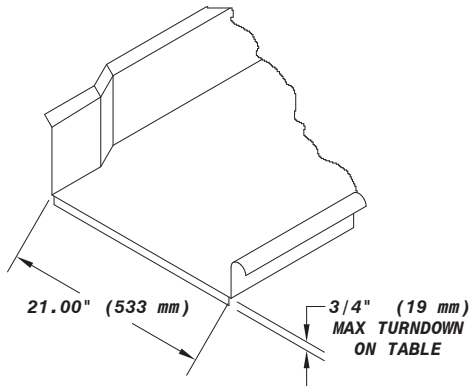
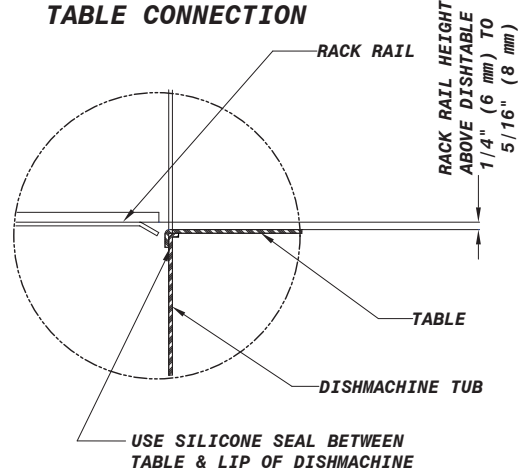

TABLE CONNECTION



MODEL NO.	MACHINE DIMENSIONS					DRAIN HEIGHT	SHIPPING INFORMATION					
	HEIGHT	HEIGHT WITH DOOR OPEN	LENGTH BETWEEN DISHTABLES	DEPTH			WEIGHT	CLASS	CUBE	HEIGHT	WIDTH	DEPTH
CREW® 66	65-3/4" (1670 mm)	93" (2362 mm)	66" (1676 mm)	30" (762 mm)		6-1/2" (165 mm)	1220 lbs (553 kg)	92.5	204.83 cu. ft.	89" (2261 mm)	97" (2464 mm)	41" (1041 mm)

OPERATING CAPACITY			
	High-Temperature	Chemical Sanitizing	
Racks per Hour	223	223	
Dishes per Hour	5,575	5,575	
Glasses per Hour	8,028	8,028	

WATER REQUIREMENTS	
Inlet Temperature (minimum)	
With 40° F (22.2° C) Rise Booster Heater	140° F (60° C)
With 70° F (38.9° C) Rise Booster Heater	110° F (43° C)
Gallons per Hour	78 gal (295 L)
Gallons per Rack	0.35 gal (1.3 L)
Waterline Size IPS (minimum)	1/2"
Drainline Size IPS (minimum)	1-1/2"
Flow Pressure (PSI)	15
Flow Rate GPM (minimum)	1.30 (4.9 LPM)
Wash Tank Capacity	35.60 gal (135 L)

OPERATING TEMPERATURES			
	High-Temperature	Chemical Sanitizing	
Pre-Wash	110 - 140° F (43 - 60° C)	110 - 120° F (43 - 49° C)	
Wash (minimum)	160° F (71° C)	120° F (49° C)	
Rinse (minimum)	180° F (82° C)	120° F (49° C)	

WASH PUMPS	
Pre-Wash Pump Motor	2 hp
Wash Pump Motor	3 hp
Pre-Wash Pump Capacity	220 GPM (833 LPM)
Wash Pump Capacity	270 GPM (1022 LPM)

ELECTRICAL REQUIREMENTS*			
Approximate Total Load AMPS			
	Electric Tank Heat	Steam	
208V/60HZ/3PH	66.5	16.5	
208V/60HZ/1PH	108.5	22.0	
230V/60HZ/3PH	61.1	15.9	
230V/60HZ/1PH	102.1	21.2	
460V/60HZ/3PH	28.4	8.0	

CONVEYOR	
Conveyor Motor	1/4 hp
Conveyor Speed (feet per minute)	6.07 FPM (1.85 MPM)

BOOSTER HEATER ELECTRICAL REQUIREMENTS*					
	40° F (22.2° C) Minimum Rise		70° F (38.9° C) Minimum Rise		
	kW	AMPS	kW	AMPS	
208V/60HZ/3PH	12	33.3	17.2	47.7	
208V/60HZ/1PH	12	57.7	17.2	82.7	
230V/60HZ/3PH	12	27.7	18	41.5	
230V/60HZ/1PH	12	47.9	18	71.9	
460V/60HZ/3PH	12	13.8	18	20.7	

VENTING REQUIREMENTS	
Input End	200 CFM
Output End	200 CFM
Total CFM	400 CFM

STEAM COIL TANK HEAT (STEAM MODELS ONLY)	
Steam Connection IPS	3/4"
Steam Flow Pressure (PSIG)	10-20
Consumption @ 15 PSIG (lbs/hr)	60

*Total amp draw for a single point connection with onboard booster heater (3 phase only) is calculated by adding the amp load for the booster heater to the amp load for the machine.
HOW TO SPECIFY: CREW® 66

Jackson WWS, Inc.
 Shipping Address: 6209 North U.S. Highway 25E, Gray, KY 40734
 Mailing Address: P.O. Box 1060, Barbourville, KY 40906
 Telephone: 888-800-5672 • Fax: 606-523-1799
 Email: info@jacksonwws.com
 07610-003-82-61 [06/07/16]

www.jacksonwws.com