

Project _____
 Item _____
 Quantity _____
 CSI Section 11400
 Approval _____
 Date _____

TempStar® HH/GPX

Models

TempStar® HH/GPX



Standard Features

- Multi-cycle timer (Extra Heavy, Heavy, Medium, Normal)
- Extended 15 second high temperature rinse provides superior coverage and rapid drying
- 20-3/4" wide X 27" high (527 mm X 686 mm) opening accommodates 18" X 26" (457 mm X 660 mm) sheet pans and 60 quart mixing bowls
- Auto-fill/auto-start
- Door switch
- External gas booster heater
 - Capable of minimum 70°F (38.9°C) degree temperature rise
 - Recirculates water through stainless steel coils in wash tank to maintain 150°F (66°C) degree minimum temperature
- Hi-limit thermostat and low water protection
- Pressure regulator
- Side mounted controls
- Unique lower counter-rotating wash arms and upper wash arm provide optimum spray coverage and superior cleaning action
- Unique split-door design for installations with low ceiling heights
- Large scrap basket
- Self-draining stainless steel pump
- Detergent/rinse additive signal connection fuse box
- Vent fan control

- Delime/manual wash switch
- Adjustable bullet feet
- Uses standard 20" X 20" (508 mm X 508 mm) racks
- Front dress panel

Mandatory Specs

- Specify incoming water temperature
- Specify how far booster will be placed from unit
- Specify altitude for proper booster size

Options

- Water Hammer Arrestor
- Flanged Feet
- Drain Quench System
- Scaltrol
- False Panel
- Door Interlock

Accessories

- 36-Compartment Rack
 - 4-1/8" tall (105 mm)
 - 5-5/8" tall (143 mm)
 - 7" tall (178 mm)
- Combination Rack
- Peg Rack
- Sheet Pan Rack - for 18" X 26" (457 mm X 660 mm) baking pans

Specifications

Uses 1.36 gallons (5 liters) of 180°F (82°C) water per rack

Total automatic normal cycle - 62 seconds

53 racks per hour normal cycle

2 hp wash pump motor

Single point connections for all utilities

Field convertible from straight through to corner and vice versa

Durable stainless steel construction



Intertek



Intertek

Legend

- A — Electrical Connection
- B — 1/2" NPT 110°F Water Inlet
- C — 1-1/2" NPT Drain Connection
- D — 4" O.D. Vent Pipe Connection Flue to be Installed to Meet National and Local Codes by Installing Contractor

All machine heat for the wash tank and final rinse is provided by the booster heater. Jackson provides the interconnections for the water from the dishmachine to the booster heater. Dishmachine and booster heater require separate electrical connections. All dimensions in inches. All vertical dimensions are +/- 1/2" from floor due to adjustable bullet feet.

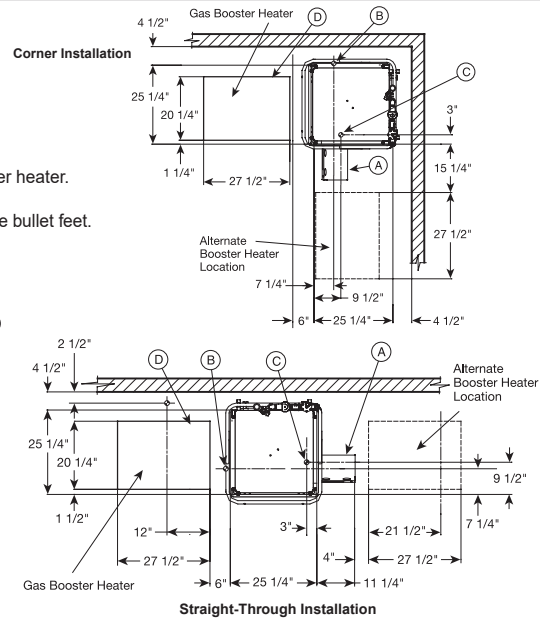
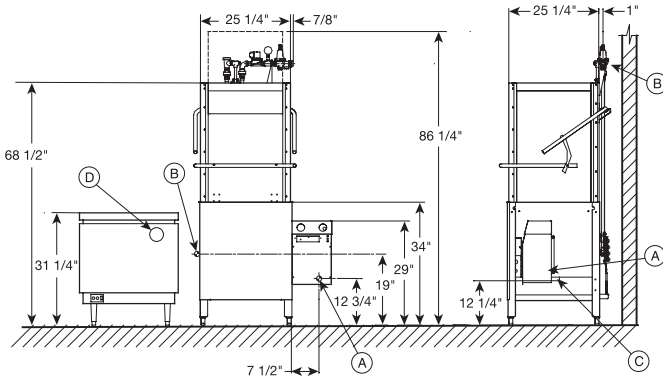

MODEL NO.	MACHINE DIMENSIONS				DRAIN HEIGHT	SHIPPING INFORMATION					
	HEIGHT	WIDTH	DEPTH	DEPTH		WEIGHT	CLASS	CUBE	HEIGHT	WIDTH	DEPTH
TempStar® HH/GPX	76-3/4" (1949 mm)	25-1/4" (641 mm)	25-1/4" (641 mm)	11-3/4" (298 mm)	420 lbs (191 kg)	200	74.9 cu. ft.	79" (2007 mm)	33" (838 mm)	49" (1245 mm)	

DIMENSION REQUIREMENTS

Minimum Ceiling Height (Recommended)	88" (2 meters)
Wall Clearance (Minimum)	4" (102 mm)
Standard Table Height	34" (864 mm)
Inside Clearance	27" (686 mm)
Machine Height with Door Open	86-1/4" (2190.75 mm)

OPERATING CAPACITY

Racks per Hour	Normal 53	Medium 28	Heavy 19	Extra Heavy 11
OPERATING CYCLE (seconds)	Wash	Rinse	Dwell	Total Cycle
Normal	45	15	2	62
Medium	103	15	2	120
Heavy	163	15	2	180
Extra Heavy	283	15	2	300

OPERATING TEMPERATURES

Wash (Minimum)	150°F (66 °C)
Rinse (Minimum)	180°F (82 °C)

APPROXIMATE TOTAL LOAD AMPS

	AMPS
115V/60HZ/1PH	25
208V/60HZ/1PH	13
208V/60HZ/3PH	13
230V/60HZ/1PH	13
230V/60HZ/3PH	13

GAS REQUIREMENTS

	Maximum	Minimum
Natural Gas (Inches-water column)	10.5 (267 mm)	5.0 (127 mm)
LP Propane Gas (Inches-water column)	13.0 (330 mm)	11.0 (292 mm)
Gas Booster Capacity (BTU)		
Input	105,000	
Output	84,800	

WATER REQUIREMENTS

Inlet Temperature	
40°F / (4°C) Rise	140°F (60°C)
70°F / (21°C) Rise	110°F (43°C)
Gallons per Hour	72.1 gal (273 L)
Waterline Size IPS (Minimum-inches)	1/2"
Drainline Size IPS (Minimum-Inches)	1-1/2"
Flow Pressure (PSI)	15-25
Wash Tank Capacity	8 gal (30 L)
Booster Tank Capacity	3 gal (11 L)
Pump Capacity (GPM)	73 gal (276 L)

WASH PUMP MOTOR

Wash Pump Motor	2 hp
-----------------	------

HOW TO SPECIFY: TempStar® HH/GPX

Jackson WWS, Inc.

Shipping Address: 6209 North U.S. Highway 25E, Gray, KY 40734
 Mailing Address: P.O.Box 1060, Barbourville, KY 40906
 Telephone: 888-800-5672 • Fax: 606-523-1799
 Email: info@jacksonwws.com
 07610-002-66-62 [03/26/18]

www.jacksonwws.com