

RackStar® 44

Project _____
 Item _____
 Quantity _____
 CSI Section 11400
 Approval _____
 Date _____

Models

RackStar 44



Standard Features

- Adjustable Rinse System
- Rainbow Rinse™ with arched rinse arm design
- 19-3/4" (502 mm) clearance
- WISR® Cleaning System
- Double-wall insulated doors retain heat, keeping wash water hot & generating less heat in the dishroom
- Self-cleaning wash arms
- Fully automatic, including auto-fill
- Adjustable vent cowl collars
- Exclusive EnergyGuard™ controls
- Self-draining stainless steel wash pump
- Digital LED control panel
- Strike plate table limit switch
- Large front access for ease of maintenance
- Stainless steel strainer pans
- Splash shields
- Stainless steel frame and legs
- Exhaust vent fan control
- 15kW wash tank heater
- Front dress panel
- Adjustable bullet feet

Mandatory Specs

Specify:

- Electric
 Steam

Specify Voltage _____

Specify Sanitizing Method:

- High Temperature
 Chemical Sanitizing

Specify Direction of Operation:

- Left to Right
 Right to Left

Options

- Higher than Standard Chamber Height
 Onboard Booster
 40° F (22.2° C) Rise
 70° F (38.9° C) Rise
 Single Point Connection with Onboard Booster (3 phase only)
 Steam Booster Heater
 23" (584 mm) Unhooded Side Loader
 30" (762 mm) Unhooded Side Loader
 1/2" Pressure Regulator
 Flanged Feet
 Prison Package

Accessories

- 36-Compartment Rack
 4-1/8" tall (104 mm)
 5 - 5/8" tall (143 mm)
 7" tall (178 mm)
 Combination Rack
 Peg Rack
 Sheet Pan Rack
 Drain Quench System
 Scaltrol
 Water Hammer Arrestor

Specifications

Uses 0.35 gallons of water (1.32 liters) per rack in Econo Rinse mode

Uses 0.52 gallons of water (1.97 liters) per rack in Turbo Rinse mode

Cleans 223 racks per hour

Durable stainless steel construction



Intertek



RackStar® 44

Left to Right

LEGEND

- A - Electrical Connection
- B - Main Water Inlet
(1/2" NPT, 110 °F MIN (18 kW Booster),
140 °F MIN (12 kW Booster), or 180 °F MIN
(No Booster or Supplied from Steam Booster))
- C - Drain Connection
(1 1/2" NPT)
- D - Vent Connections
(Including Dampers)
- E - Steam Connection
(3/4" NPT)

- - Open Door
- - High Hood Option

All dimensions from the floor can be increased 1 3/4" using the machine's adjustable feet.

Items in red are not supplied with the machine.

Items in blue are for the Steam option.

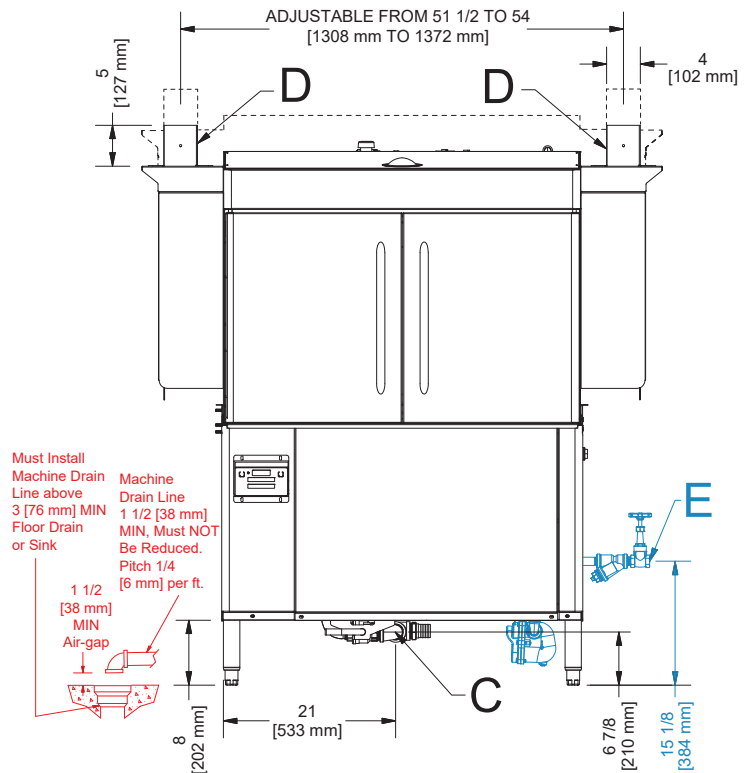
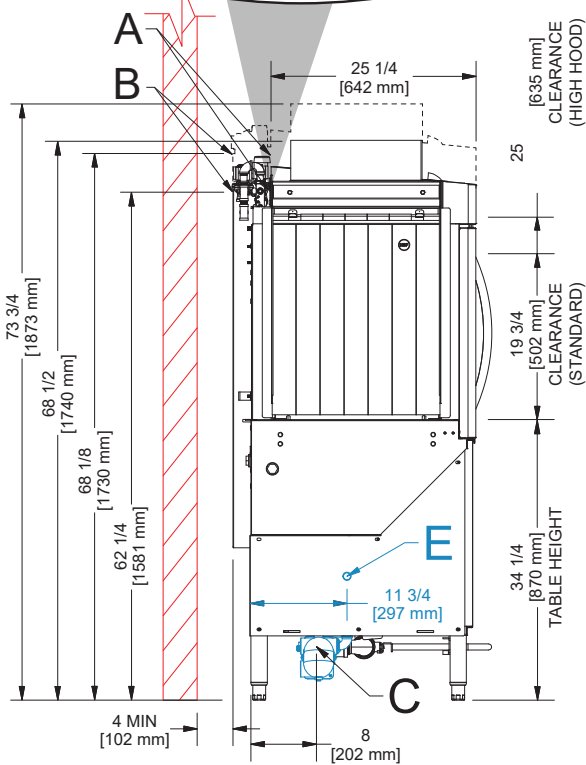
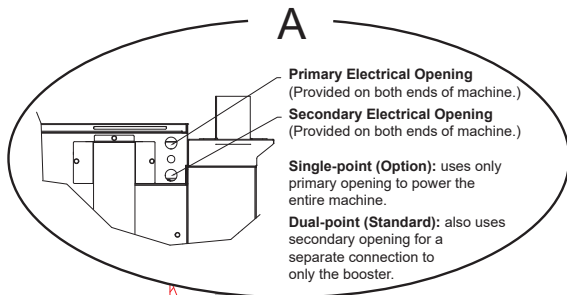
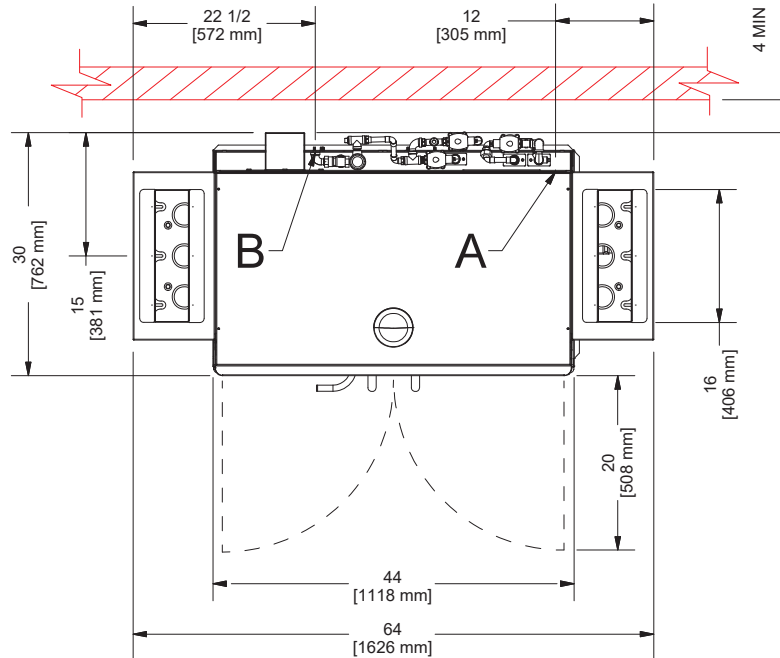

Must Install
Machine Drain
Line above
3 [76 mm] MIN
Floor Drain
or Sink

Machine
Drain Line
1 1/2 [38 mm]
MIN, Must NOT
Be Reduced.
Pitch 1/4
[6 mm] per ft.

1 1/2
[38 mm]
MIN
Air-gap

RECOMMENDED TABLE FABRICATION

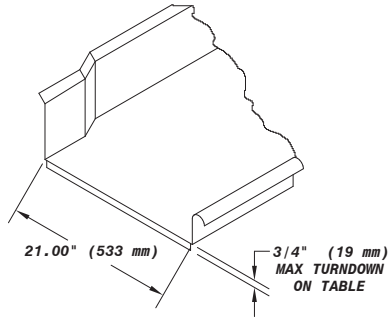
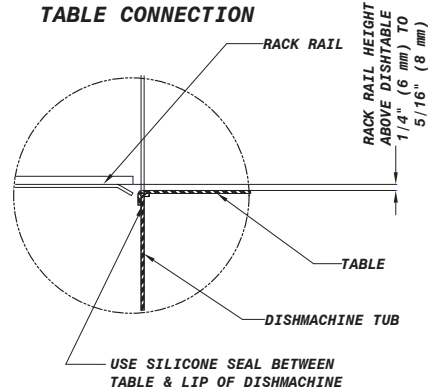

TABLE CONNECTION



MODEL NO.	MACHINE DIMENSIONS					DRAIN HEIGHT	SHIPPING INFORMATION					
	HEIGHT	LENGTH BETWEEN DISHTABLES	DEPTH	DEPTH WITH DOORS OPEN	WEIGHT		CLASS	CUBE	HEIGHT	WIDTH	DEPTH	
RackStar 44	64-1/2" (1632 mm)	44" (1118 mm)	30" (762 mm)	50" (1270 mm)	6-7/8" (210 mm)	802 lbs (364 kg)	150	131.94 cu. ft.	75" (1905 mm)	76" (1931 mm)	40" (1016 mm)	
RackStar 44 Tall Chamber	73-3/4" (1874 mm)	44" (1118 mm)	30" (762 mm)	50" (1270 mm)	6-7/8" (210 mm)	812 lbs (369 kg)	150	131.94 cu. ft.	75" (1905 mm)	76" (1931 mm)	40" (1016 mm)	

OPERATING CAPACITY		
	High-Temperature	Chemical Sanitizing
Racks per Hour	223	223
Dishes per Hour	5,575	5,575
Glasses per Hour	8,028	8,028

OPERATING TEMPERATURES		
	High-Temperature	Chemical Sanitizing
Wash (minimum)	160° F (71° C)	120° F (49° C)
Rinse (minimum)	180° F (82° C)	120° F (49° C)

ELECTRICAL REQUIREMENTS*				
	Power Supply	Total Load	Minimum Circuit Ampacity	Maximum Overcurrent Protection
70 °F Rise	208/60/1	173.5	176.9	190
	230/60/1	145.2	148.2	160
	208/60/3	99.9	102.2	110
	230/60/3	85.8	88.0	95
	460/60/3	43.1	44.2	45
40 °F Rise	208/60/1	144.7	148.1	160
	230/60/1	121.2	124.2	135
	208/60/3	85.3	87.6	95
	230/60/3	72.0	74.2	80
	460/60/3	36.1	37.2	40
No Booster	208/60/1	87.0	90.4	100
	230/60/1	73.3	76.3	85
	208/60/3	52.0	54.3	60
	230/60/3	44.3	46.5	55
	460/60/3	22.3	23.4	25
Steam	208/60/1	14.9	18.3	30
	230/60/1	13.4	16.4	25
	208/60/3	10.3	12.6	20
	230/60/3	9.7	11.9	20
	460/60/3	5.0	6.1	15

WATER REQUIREMENTS	
Inlet Temperature (minimum)	
With 40° F (22.2° C) Rise Booster Heater	140° F (60° C)
With 70° F (38.9° C) Rise Booster Heater	110° F (43° C)
Gallons per Hour (Econo Rinse / Turbo Rinse)	78 gal (295 L) / 116 gal (239.1 L)
Gallons per Rack (Econo Rinse / Turbo Rinse)	0.35 gal (1.3 L) / 0.52 gal (1.97 L)
Waterline Size IPS (minimum)	1/2"
Drainline Size IPS (minimum)	1-1/2"
Flow Pressure (PSI)	15
Flow Rate GPM (minimum)	1.30 (4.9 LPM)
Wash Tank Capacity	25 gal (95 L)

WASH PUMP	
Wash Pump Motor	3 hp
Wash Pump Capacity	270 GPM (1022 LPM)

CONVEYOR	
Conveyor Motor	1/4 hp
Conveyor Speed (feet per minute)	6.07 FPM (1.85 MPM)

VENTING REQUIREMENTS	
Input End	200 CFM
Output End	200 CFM
Total CFM	400 CFM

STEAM COIL TANK HEAT (STEAM MODELS ONLY)	
Steam Connection IPS	3/4"
Steam Flow Pressure (PSIG)	10-30
Consumption @ 15 PSIG (lbs/hr)	60

HOW TO SPECIFY: RackStar 44

Jackson WWS, Inc.

Shipping Address: 6209 North U.S. Highway 25E, Gray, KY 40734
 Mailing Address: P.O. Box 1060, Barbourville, KY 40906
 Telephone: 888-800-5672 • Fax: 606-523-1799
 Email: info@jacksonwws.com
 07610-004-34-33 [03/26/19]

www.jacksonwws.com