

RackStar® 66

Project _____
 Item _____
 Quantity _____
 CSI Section 11400
 Approval _____
 Date _____

Models

RackStar 66



Standard Features

- Adjustable Rinse System
- Rainbow Rinse™ with arched rinse arm design
- 19-3/4" (502 mm) clearance
- WISR® Cleaning System
- Double-wall insulated doors retain heat, keeping wash water hot & generating less heat in the dish room
- Self-cleaning wash arms
- 22" pre-wash
- Fully automatic, including auto-fill
- Adjustable vent cowl collars
- Exclusive EnergyGuard™ controls
- Self-draining stainless steel wash pump
- Digital LED control panel
- Strike plate table limit switch
- Large front access for ease of maintenance
- Stainless steel strainer pans
- Splash shields
- Stainless steel frame and legs
- Exhaust vent fan control
- 15kW wash tank heater
- Front dress panel
- Adjustable bullet feet

Mandatory Specs

Specify:

- Electric
 Steam

Specify Voltage _____

Specify Sanitizing Method:

- High Temperature
 Chemical Sanitizing

Specify Direction of Operation:

- Left to Right
 Right to Left

Options

- Higher than Standard Chamber Height
 Onboard Booster
 40° F (22.2° C) Rise
 70° F (38.9° C) Rise
 Single Point Connection with Onboard Booster
 Steam Booster Heater
 23" (584 mm) Unhooded Side Loader
 30" (762 mm) Unhooded Side Loader
 1/2" Pressure Regulator
 Flanged Feet
 Prison Package

Accessories

- 36-Compartment Rack
 4-1/8" tall (104 mm)
 5 - 5/8" tall (143 mm)
 7" tall (178 mm)
 Combination Rack
 Peg Rack
 Sheet Pan Rack
 Drain Water Tempering Kit*
 Scaltrol
 Water Hammer Arrestor

**Requires separate electrical connection*

Specifications

Uses 0.35 gallons of water (1.32 liters) per rack in Econo Rinse mode

Uses 0.52 gallons of water (1.97 liters) per rack in Turbo Rinse mode

Cleans 223 racks per hour

22" (559 mm) pre-wash section has 3 upper and 1 lower pre-wash arms

Durable stainless steel construction



Intertek



Intertek



RackStar® 66

Left to Right

LEGEND

- A - Electrical Connection
- B - Main Water Inlet
(1/2" NPT, 110 °F MIN (18 kW Booster),
140 °F MIN (12 kW Booster), or 180 °F MIN
(No Booster or Supplied from Steam Booster))
- C - Drain Connection
(1 1/2" NPT)
- D - Vent Connections
(Including Dampers)
- E - Steam Connection
(3/4" NPT)

- — — — — - Open Door
- - - - - - - - - - - High Hood Option

All dimensions from the floor can be increased 1 3/4" using the machine's adjustable feet.

Items in red are not supplied with the machine.

Items in blue are for the Steam option.

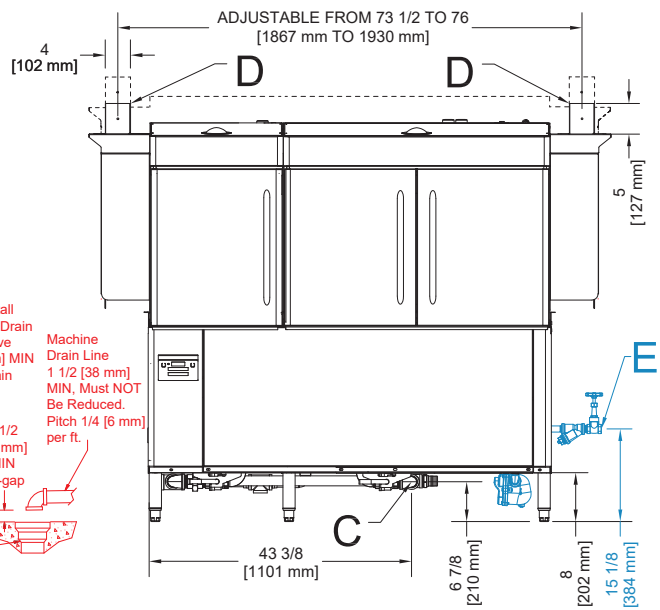
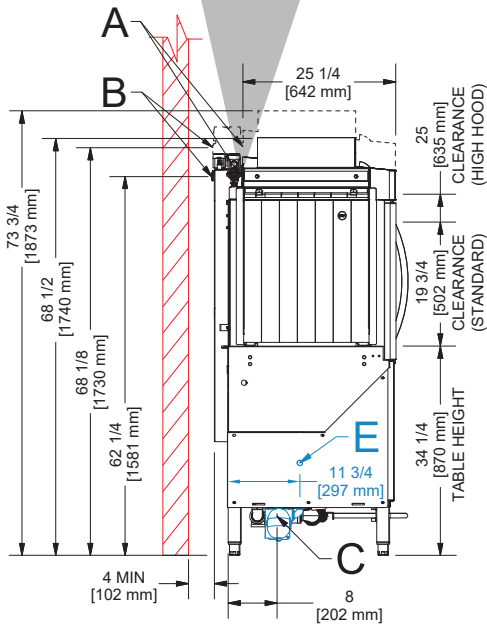
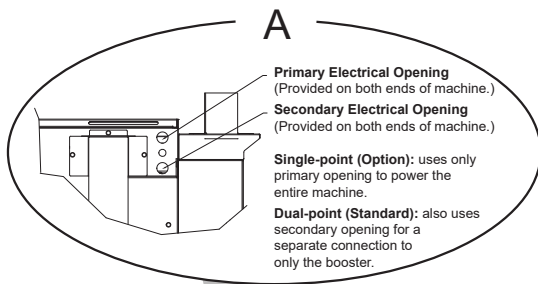
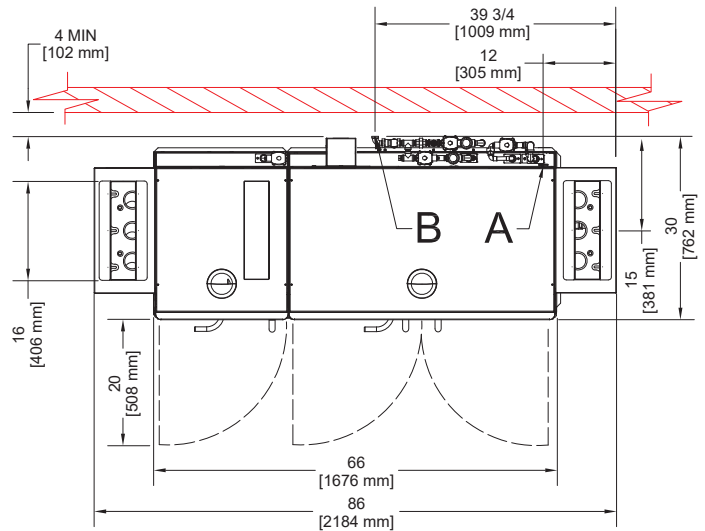

RECOMMENDED TABLE FABRICATION

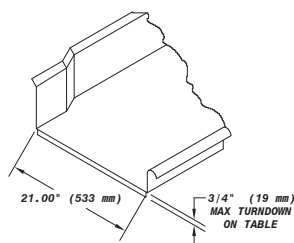
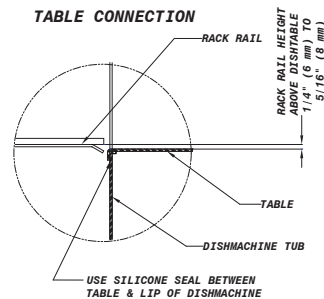

TABLE CONNECTION



LEGEND

- A - Electrical Connection
- B - Main Water Inlet
(1/2" NPT, 110 °F MIN (18 kW Booster),
140 °F MIN (12 kW Booster), or 180 °F MIN
(No Booster or Supplied from Steam Booster))
- C - Drain Connection
(1 1/2" NPT)
- D - Vent Connections
(Including Dampers)
- E - Steam Connection
(3/4" NPT)

- - Open Door
- - High Hood Option

All dimensions from the floor can be increased 1 3/4" using the machine's adjustable feet.

Items in red are not supplied with the machine.

Items in blue are for the Steam option.

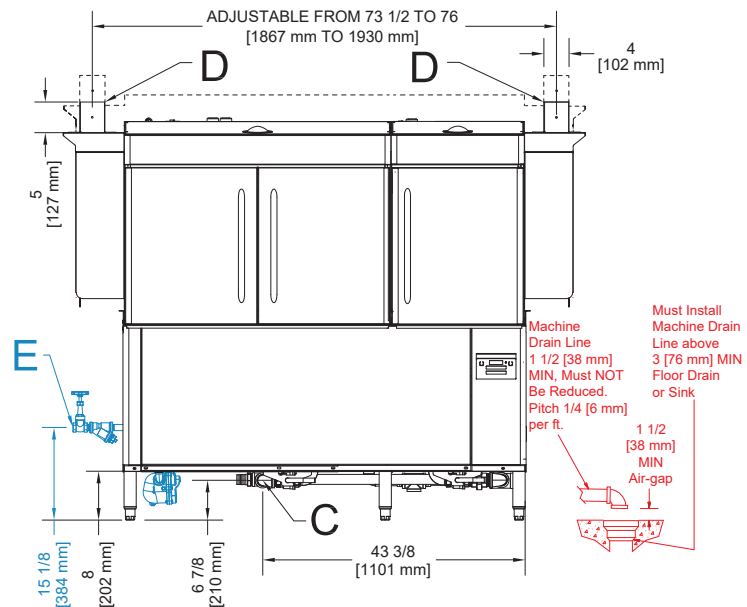
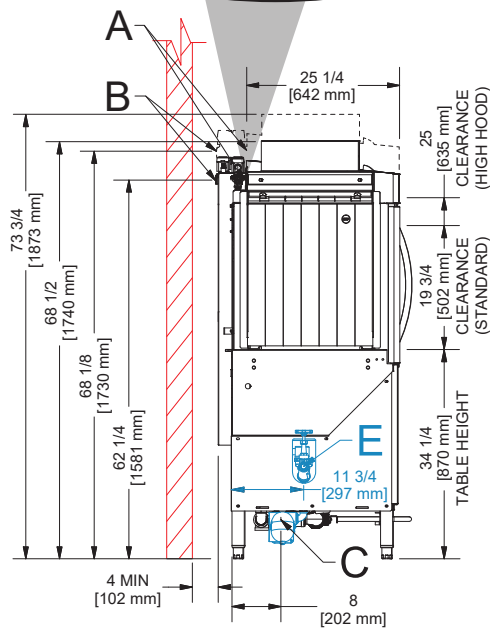
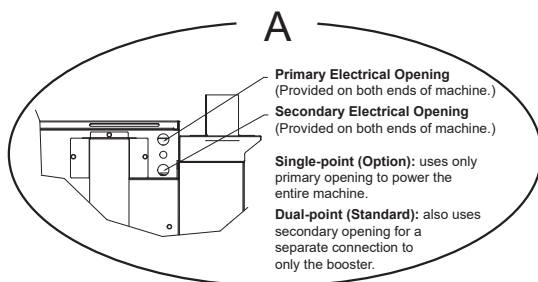
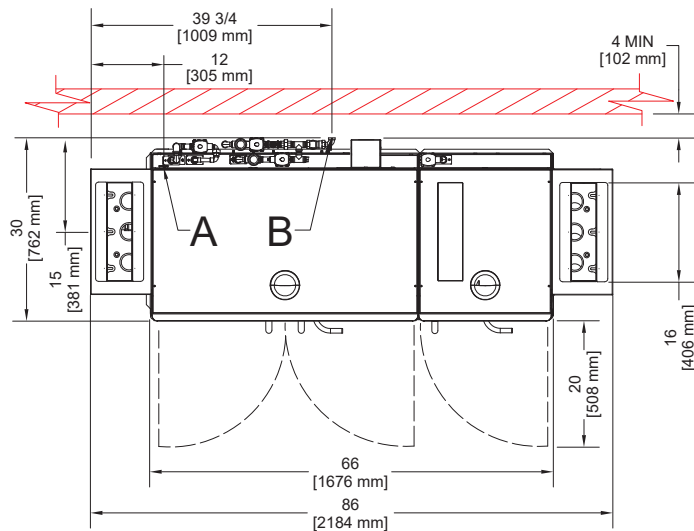

RECOMMENDED TABLE FABRICATION

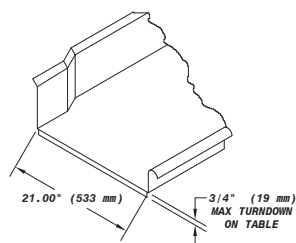
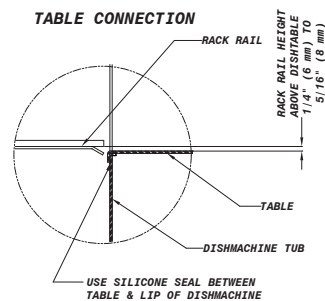

TABLE CONNECTION





RackStar® 66

| MODEL NO. | MACHINE DIMENSIONS | | | | DRAIN HEIGHT | SHIPPING INFORMATION | | | | | |
|--------------------------|--------------------|---------------------------|--------------|-----------------------|-----------------|----------------------|-------|----------------|---------------|---------------|---------------|
| | HEIGHT | LENGTH BETWEEN DISHTABLES | DEPTH | DEPTH WITH DOORS OPEN | | WEIGHT | CLASS | CUBE | HEIGHT | WIDTH | DEPTH |
| RackStar 66 | 68-1/2" (1740 mm) | 66" (1676 mm) | 30" (762 mm) | 50" (1270 mm) | 6-7/8" (210 mm) | 1,115 lbs (506 kg) | 150 | 166.67 cu. ft. | 75" (1905 mm) | 96" (2439 mm) | 40" (1016 mm) |
| RackStar 66 Tall Chamber | 73-3/4" (1874 mm) | 66" (1676 mm) | 30" (762 mm) | 50" (1270 mm) | 6-7/8" (210 mm) | 1,135 lbs (515 kg) | 150 | 166.67 cu. ft. | 75" (1905 mm) | 96" (2439 mm) | 40" (1016 mm) |

| OPERATING CAPACITY | | | ELECTRICAL REQUIREMENTS - SINGLE POINT CONNECTION | | | |
|--------------------|------------------|---------------------|---|------------|--------------------------|--------------------------------|
| | High-Temperature | Chemical Sanitizing | Power Supply | Total Load | Minimum Circuit Ampacity | Maximum Overcurrent Protection |
| Racks per Hour | 223 | 223 | WITH 18kW/70° RISE ONBOARD BOOSTER | | | |
| Dishes per Hour | 5,575 | 5,575 | 208/60/3 | 106.0 A | 108.3 A | 115 A |
| Glasses per Hour | 8,028 | 8,028 | 230/60/3 | 93.8 A | 95.9 A | 100 A |
| | | | 460/60/3 | 47.1 A | 48.2 A | 50 A |
| | | | 208/60/1 | 183.7 A | 187.1 A | 200 A |
| | | | 230/60/1 | 157.7 A | 160.7 A | 170 A |
| | | | WITH 12kW/40° RISE ONBOARD BOOSTER | | | |
| | | | 208/60/3 | 91.4 A | 93.7 A | 100 A |
| | | | 230/60/3 | 79.4 A | 81.5 A | 90 A |
| | | | 460/60/3 | 39.8 A | 40.9 A | 45 A |
| | | | 208/60/1 | 154.9 A | 158.3 A | 170 A |
| | | | 230/60/1 | 132.7 A | 135.7 A | 145 A |
| | | | WITH NO BOOSTER | | | |
| | | | 208/60/3 | 58.1 A | 60.4 A | 65 A |
| | | | 230/60/3 | 50.5 A | 52.6 A | 60 A |
| | | | 460/60/3 | 25.4 A | 26.5 A | 30 A |
| | | | 208/60/1 | 97.2 A | 100.6 A | 110 A |
| | | | 230/60/1 | 82.6 A | 85.7 A | 95 A |
| | | | STEAM TANK HEAT | | | |
| | | | 208/60/3 | 16.5 A | 18.8 A | 25 A |
| | | | 230/60/3 | 15.9 A | 18.1 A | 25 A |
| | | | 460/60/3 | 8.1 A | 9.2 A | 15 A |
| | | | 208/60/1 | 25.1 A | 28.5 A | 40 A |
| | | | 230/60/1 | 22.8 A | 25.8 A | 35 A |

| OPERATING TEMPERATURES | | | ELECTRICAL REQUIREMENTS - DUAL POINT CONNECTION | | | |
|------------------------|---------------------------|---------------------------|---|------------|--------------------------|--------------------------------|
| | High-Temperature | Chemical Sanitizing | Power Supply | Total Load | Minimum Circuit Ampacity | Maximum Overcurrent Protection |
| Pre-Wash | 110 - 140° F (43 - 60° C) | 110 - 120° F (43 - 49° C) | WITH 18kW/70° RISE ONBOARD BOOSTER | | | |
| Wash (minimum) | 160° F (71° C) | 120° F (49° C) | 208/60/3 - Machine | 58.1 A | 60.4 A | 65 A |
| Rinse (minimum) | 180° F (82° C) | 120° F (49° C) | 208/60/3 - 18kW Booster | 47.9 A | 49.2 A | 50 A |
| | | | 230/60/3 - Machine | 50.5 A | 52.6 A | 60 A |
| | | | 230/60/3 - 18kW Booster | 43.3 A | 44.6 A | 45 A |
| | | | 460/60/3 - Machine | 25.4 A | 26.5 A | 30 A |
| | | | 460/60/3 - 18kW Booster | 21.7 A | 23.0 A | 25 A |
| | | | 208/60/1 - Machine | 97.2 A | 100.6 A | 110 A |
| | | | 208/60/1 - 18kW Booster | 86.5 A | 87.8 A | 90 A |
| | | | 230/60/1 - Machine | 82.7 A | 85.7 A | 95 A |
| | | | 230/60/1 - 18kW Booster | 75.0 A | 76.3 A | 80 A |
| | | | WITH 12kW/40° RISE ONBOARD BOOSTER | | | |
| | | | 208/60/3 - Machine | 58.1 A | 60.4 A | 65 A |
| | | | 208/60/3 - 12kW Booster | 33.3 A | 34.6 A | 35 A |
| | | | 230/60/3 - Machine | 50.5 A | 52.6 A | 60 A |
| | | | 230/60/3 - 12kW Booster | 28.9 A | 30.2 A | 35 A |
| | | | 460/60/3 - Machine | 25.4 A | 26.5 A | 30 A |
| | | | 460/60/3 - 12kW Booster | 14.4 A | 15.7 A | 20 A |
| | | | 208/60/1 - Machine | 97.2 A | 100.6 A | 110 A |
| | | | 208/60/1 - 12kW Booster | 57.7 A | 59.0 A | 60 A |
| | | | 230/60/1 - Machine | 82.7 A | 85.7 A | 95 A |
| | | | 230/60/1 - 12kW Booster | 50.0 A | 51.3 A | 55 A |

| WATER REQUIREMENTS | | WASH PUMPS | |
|--|--------------------------------------|------------------------|--------------------|
| Inlet Temperature (minimum) | | Pre-Wash Pump Motor | 2 hp |
| With 40° F (22.2° C) Rise Booster Heater | 140° F (60° C) | Wash Pump Motor | 3 hp |
| With 70° F (38.9° C) Rise Booster Heater | 110° F (43° C) | Pre-Wash Pump Capacity | 220 GPM (833 LPM) |
| Gallons per Hour (Econo Rinse / Turbo Rinse) | 78 gal (295 L) / 116 gal (239.1 L) | Wash Pump Capacity | 270 GPM (1022 LPM) |
| Gallons per Rack (Econo Rinse / Turbo Rinse) | 0.35 gal (1.3 L) / 0.52 gal (1.97 L) | | |
| Waterline Size IPS (minimum) | 1/2" | | |
| Drainline Size IPS (minimum) | 1-1/2" | | |
| Flow Pressure (PSI) | 15 | | |
| Flow Rate GPM (minimum) | 1.30 (4.9 LPM) | | |
| Wash Tank Capacity | 25 gal (95 L) | | |

| CONVEYOR | | VENTING REQUIREMENTS | |
|----------------------------------|---------------------|----------------------|---------|
| Conveyor Motor | 1/4 hp | Input End | 200 CFM |
| Conveyor Speed (feet per minute) | 6.07 FPM (1.85 MPM) | Output End | 200 CFM |
| | | Total CFM | 400 CFM |

| STEAM COIL TANK HEAT (STEAM MODELS ONLY) | |
|--|-------|
| Steam Connection IPS | 3/4" |
| Steam Flow Pressure (PSIG) | 10-30 |
| Consumption @ 15 PSIG (lbs/hr) | 60 |

HOW TO SPECIFY: RackStar 66

Jackson WWS, Inc.

Shipping Address: 6209 North U.S. Highway 25E, Gray, KY 40734
 Mailing Address: P.O. Box 1060, Barbourville, KY 40906
 Telephone: 888-800-5672 • Fax: 606-523-1799
 Email: info@jacksonwws.com
 07610-004-36-87 [12/15/2020]

www.jacksonwws.com

We reserve the right to change specifications in this bulletin without incurring any obligation for equipment previously or subsequently sold.