

TECHNICAL MANUAL

**INSTALLATION MANUAL FOR EXPORT UNITS
SERVICE MANUAL FOR DOMESTIC UNITS**

ELECTRICALLY HEATED MODELS:

200

200B

200LT

STEAM HEATED MODELS:

200S



REVISION	REVISION DATE	MADE BY	APPLICABLE ECN	DETAILS
C	10-30-2000	MAW	5709	Update to current design.
D	01-12-2004	MAW	6946	Added 200S model.
E	02-10-2006	MAW	7006, 7231	Changed thermostat bracket from 05700-011-73-72 to 05700-011-81-64. Change rinse thermostat from 05930-12-71-29 to 05930-510-03-79. Delete thermostat mounting bracket and decal from booster tank assembly. Added False Panel Kit Option. Added service procedures section including the solenoid valve, vacuum breaker, and rinse thermostat replacement.



200 NB

- 200 = Electrically heated, high temp, hot water sanitizing, no rinse booster, door-type dish-machine
- 200B = Electrically heated, high temp, hot water sanitizing, with booster heater, door-type dish-machine
- 200 LT = Electrically heated, low temp, chemical sanitizing, no rinse booster, door-type dish-machine
- 200 S = Steam heated, high temp, hot water sanitizing, door-type dishmachine

Model: _____

Serial No.: _____

Installation Date: _____

Service Rep. Name: _____

Phone No.: _____



SECTION	DESCRIPTION	PAGE
I.	SPECIFICATIONS	
	Operating Capacities	2
	Dimensions	3
	Table Dimensions	4
II.	INSTALLATION/OPERATION INSTRUCTIONS	
	Installation Instructions	6
	Electrical Installation Instructions	7
	Detergent Control	8
	Operation Instructions	9
III.	PREVENTATIVE MAINTENANCE	12
IV.	TROUBLESHOOTING SECTION	14
V.	SERVICE PROCEDURES	
	Solenoid Valve Replacement Kit	17
	Vacuum Breaker Replacement Kit	21
	Rinse Thermostat Replacement Kit	23
VI.	DRAWING/PARTS SECTION	
	Control Box Assembly	28
	Hood Assembly	30
	Cantilever Arm Assembly	31
	Tub Assembly	33
	Rinse Tank Assembly	35
	Wash Heaters - Rinse Heaters	36
	Motor Assembly	37
	Frame Assembly	38
	Incoming Plumbing / Outlet Plumbing Assembly	39
	Solenoid Valve Repair Kit / Vacuum Breaker Repair Kit	41
	Steam Coil Assembly	42
	Incoming Steam Plumbing Assembly	43
	Wash & Rinse Arms/Manifold Assemblies	44
	Safety Door Interlock (SDI) Option	46
	Exhaust Fan Control Option	47
	False Panel Kit Option	48
VII.	ELECTRICAL DIAGRAMS	
	200/200B/200LT 208 - 230 - 460 V, 50/60 HZ, single/three phase	50
	200S 208 - 230 - 460 V, 50/60 HZ, single/three phase	51

SECTION 1: SPECIFICATION INFORMATION

SECTION 1: SPECIFICATION INFORMATION

OPERATING CAPACITIES

PERFORMANCE/CAPABILITIES

OPERATING CAPACITY (RACKS/HOUR)

RACKS PER HOUR	57
DISHES PER HOUR	1425
GLASSES PER HOUR	1425

OPERATING CYCLE (SECONDS)

WASH TIME	45
RINSE TIME	11
TOTAL CYCLE	58

TANK CAPACITY (GALLONS)

WASH TANK (MINIMUM)	8.0
BOOSTER TANK	3.0

WASH PUMP CAPACITY

GALLONS PER MINUTE	150
--------------------	-----

TEMPERATURES

WASH---°F (MINIMUM)	150
RINSE---°F (MINIMUM)	180
WASH---°F (MINIMUM) (200 LT)	130
RINSE---°F (MINIMUM) (200 LT)	130

NOTE: Always refer to the machine data plate for specific electrical and water requirements. The material provided on this page is for reference only and may be subject to change without notice.

STEAM REQUIREMENTS

COIL SIZE	3/4"
STEAM FLOW PRESSURE (P.S.I.)	10-20
CONSUMPTION @ 15 P.S.I. (LBS/HR)	45

WATER REQUIREMENTS (MINIMUM)

INLET TEMPERATURE (200)	180°F
INLET TEMPERATURE (200B)(40° Rise)	140°F
INLET TEMPERATURE (200B)(70° Rise)	110°F
INLET TEMPERATURE (200LT)	140°F
INLET TEMPERATURE (200S)	110°F
GALLONS PER HOUR	52.2
GALLONS PER RACK	0.92
WATER LINE SIZE NPT	3/4"
DRAIN LINE SIZE NPT	1 1/2"
FLOW PRESSURE P.S.I. (Optimum)	20 ± 5
MINIMUM CHLORINE REQUIRED (PPM)(200LT)	50

ELECTRICAL REQUIREMENTS

WASH PUMP MOTOR HP	1
--------------------	---

NOTE: Typical Electrical Circuit is based upon (1) 125% of the full amperage load of the machine and (2) typical fixed-trip circuit breaker sizes as listed in the NEC 2002 Edition. Local codes may require more stringent protection than what is displayed here. Always verify with your electrical service contractor that your circuit protection is adequate and meets all applicable national and local codes. These numbers are provided in this manual simply for reference and may change without notice at any given time.

MODEL	VOLTS	PH	HZ	RINSE HEATER RATINGS	TOTAL AMPS	TYPICAL ELECTRICAL CIRCUIT
200B	208	1	60	12KW@230	72 A	90 AMP
200B	230	1	60	12KW@230	79 A	100 AMP
200B	208	3	60	12KW@230	40 A	50 AMP
200B	230	3	60	12KW@230	44 A	60 AMP
200B	460	3	60	12KW@230	22 A	25 AMP
200B	208	1	60	14KW@230	79 A	100 AMP
200B	230	1	60	14KW@230	87 A	110 AMP
200B	208	3	60	14KW@230	44 A	60 AMP
200B	230	3	60	14KW@230	49 A	70 AMP
200B	460	3	60	14KW@230	25 A	36 AMP
200	208	1	60	N/A	29 A	40 AMP
200	230	1	60	N/A	31 A	40 AMP
200	208	3	60	N/A	15 A	20 AMP
200	230	3	60	N/A	16 A	20 AMP
200	460	3	60	N/A	8 A	15 AMP
200/LT	208	1	60	N/A	29 A	40 AMP
200/LT	230	1	60	N/A	31 A	40 AMP
200/LT	208	3	60	N/A	15 A	20 AMP
200/LT	230	3	60	N/A	16 A	20 AMP
200/LT	460	3	60	N/A	8 A	15 AMP
200S	208	1	60	N/A	7 A	15 AMP
200S	230	1	60	N/A	7 A	15 AMP
200S	208	3	60	N/A	4 A	15 AMP
200S	230	3	60	N/A	4 A	15 AMP
200S	460	3	60	N/A	4 A	15 AMP

SECTION 1: SPECIFICATION INFORMATION

DIMENSIONS

LEGEND:

A- Drain 1 1/2" NPT

B- Water inlet 3/4" NPT

C- Electrical connection

D- Standard wall clearance, with dish table 4"

E- Model 200B booster tank location

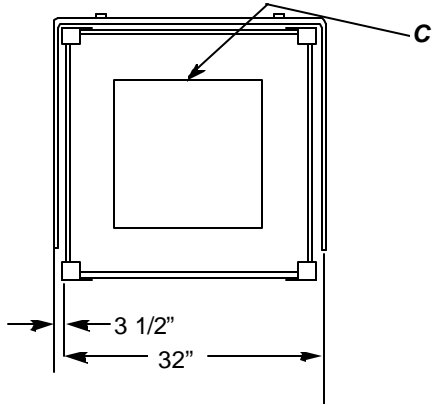
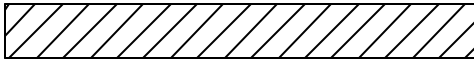

**TOP VIEW
FRONT**

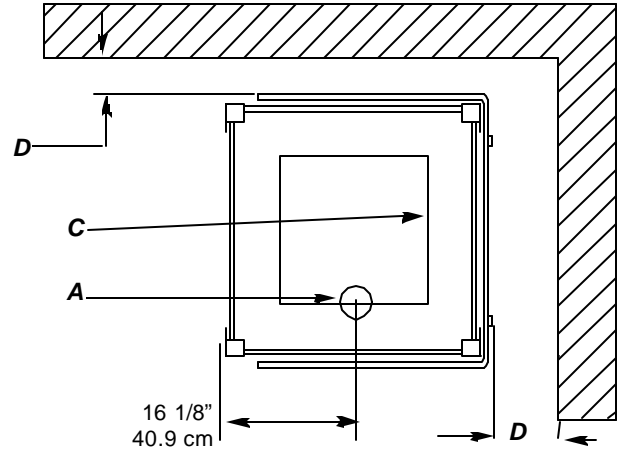

**TOP VIEW
CORNER CONVERSION**

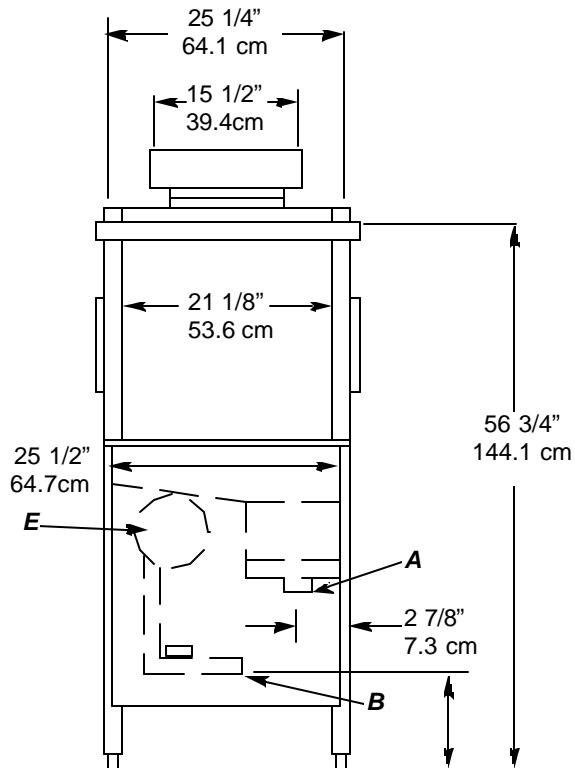

FRONT VIEW

10 3/4"
27.3 cm

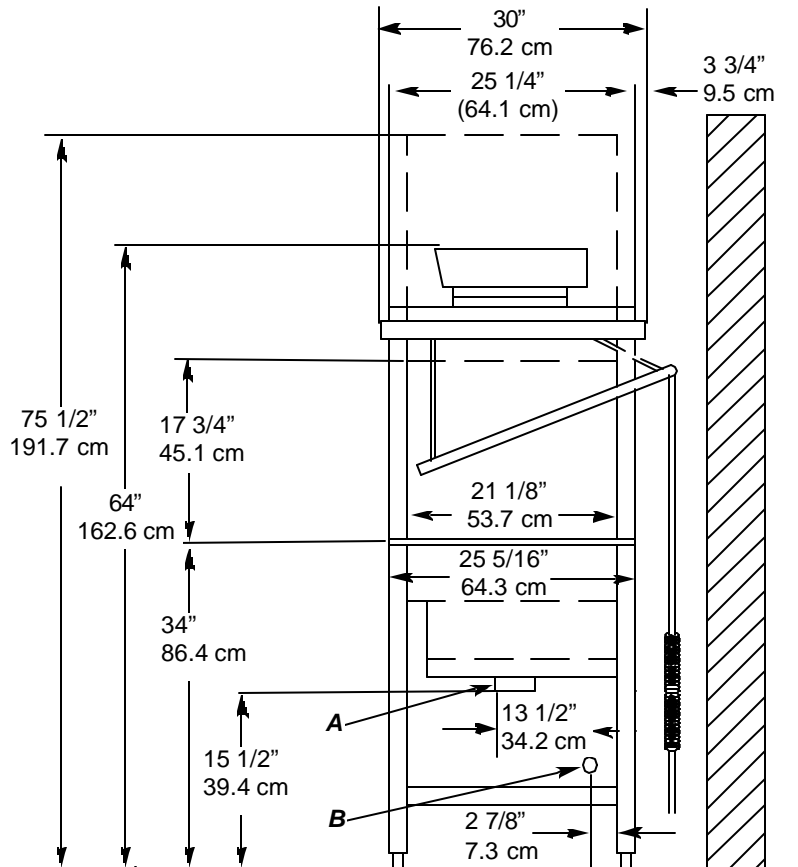

RIGHT SIDE VIEW

TABLE DIMENSIONS

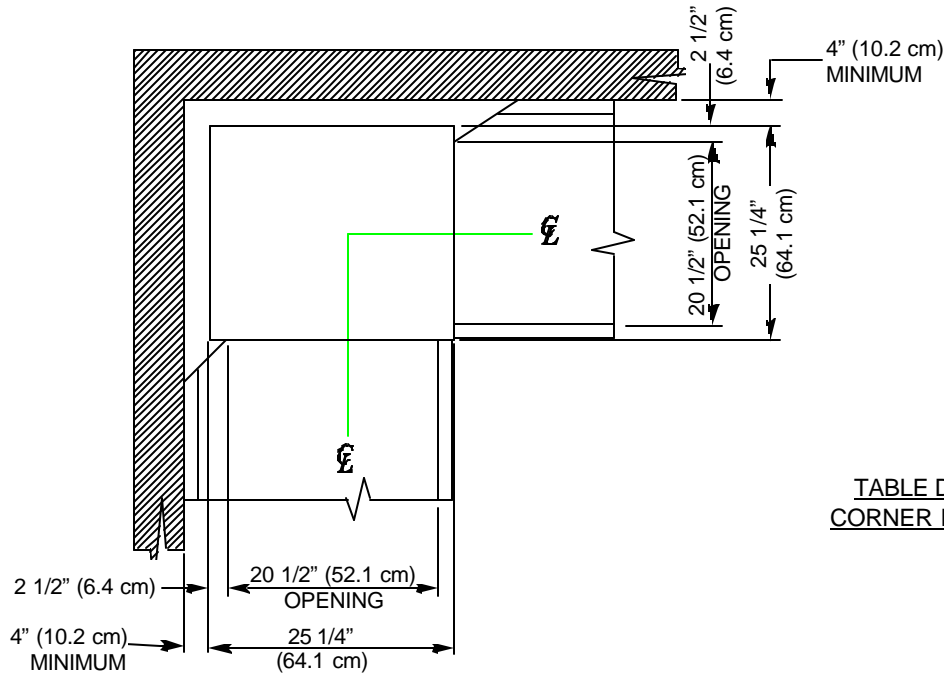

TABLE DIMENSIONS
CORNER INSTALLATION

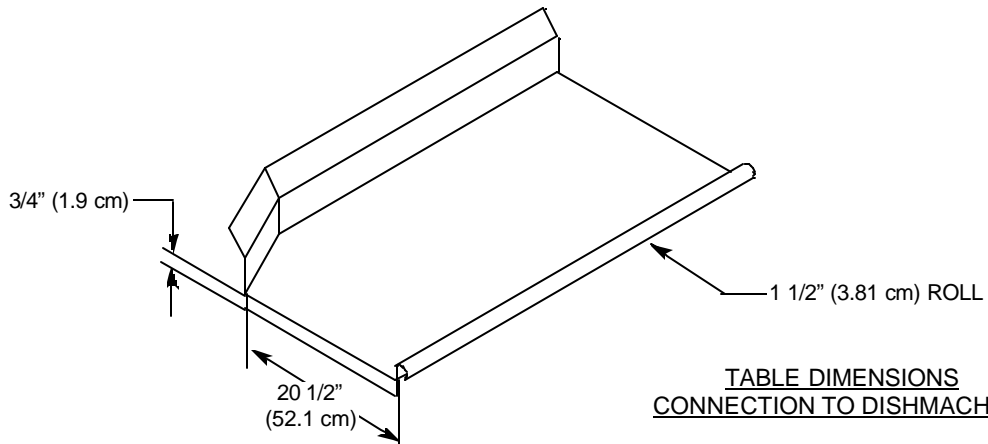

TABLE DIMENSIONS
CONNECTION TO DISHWASHER

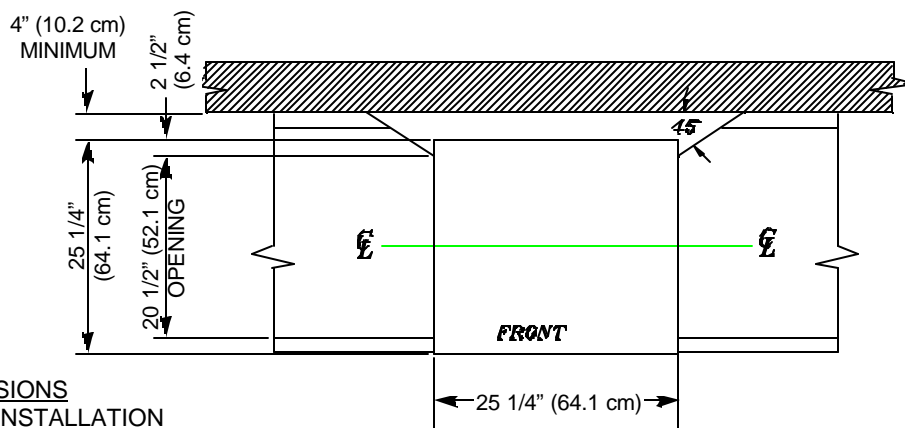

TABLE DIMENSIONS
STRAIGHT THROUGH INSTALLATION

**SECTION 2:
INSTALLATION/OPERATION
INSTRUCTIONS**

SECTION 2: INSTALLATION/OPERATION INSTRUCTIONS

INSTALLATION INSTRUCTIONS

VISUAL INSPECTION: Before installing the unit, check the container and machine for damage. A damaged container is an indicator that there may be some damage to the machine. If there is damage to both the container and machine, do not throw away the container. The dishmachine has been inspected and packed at the factory and is expected to arrive to you in new, undamaged condition. However, rough handling by carriers or others may result in there being damage to the unit while in transit. If such a situation occurs, do not return the unit to Jackson; instead, contact the carrier and ask them to send a representative to the site to inspect the damage to the unit and to complete an inspection report. You must contact the carrier within 48 hours of receiving the machine. Also, contact the dealer through which you purchased the unit.

UNPACKING THE DISHMACHINE: Once the machine has been removed from the container, ensure that there are no missing parts from the machine. This may not be obvious at first. If it is discovered that an item is missing, contact Jackson immediately to have the missing item shipped to you.

LEVEL THE DISHMACHINE: The dishmachine is designed to operate while being level. This is important to prevent any damage to the machine during operation and to ensure the best results when washing ware. The unit comes with adjustable bullet feet, which can be turned using a pair of pliers or by hand if the unit can be raised safely. Ensure that the unit is level from side to side and from front to back before making any connections.

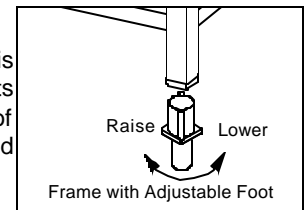

PLUMBING THE DISHMACHINE: All plumbing connections must comply with all applicable local, state, and national plumbing codes. The plumber is responsible for ensuring that the incoming water line is thoroughly flushed prior to connecting it to any component of the dishmachine. It is necessary to remove all foreign debris from the water line that may potentially get trapped in the valves or cause an obstruction. Any valves that are fouled as a result of foreign matter left in the water line, and any expenses resulting from this fouling, are not the responsibility of the manufacturer.

CONNECTING THE DRAIN LINE: The drain for the 200 series models covered in this manual is a gravity discharge drain. All piping from the 1 1/2" MNPT connection on the waste accumulator must be pitched (1/4" per foot) to the floor or sink drain. All piping from the machine to the drain must be a minimum 1 1/2" NPT and shall not be reduced. There must also be an air gap between the machine drain line and the floor sink or drain. If a grease trap is required by code, it should have a flow capacity of 5 gallons per minute.

WATER SUPPLY CONNECTION: Ensure that you have read the section entitled "PLUMBING THE DISHMACHINE" above before proceeding. Install the water supply line (3/4" pipe size minimum) to the dishmachine line strainer using copper pipe. It is recommended that a water shut-off valve be installed in the water line between the main supply and the machine to allow access for service. The water supply line is to be capable of 20 ± 5 PSI "flow" pressure at the recommended temperature indicated on the data plate.

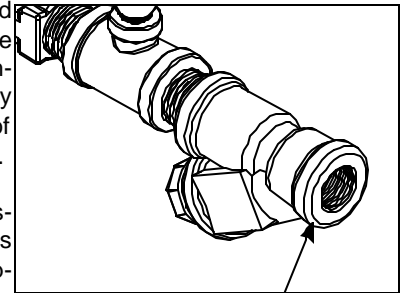

Incoming Plumbing Connection

In areas where the water pressure fluctuates or is greater than the recommended pressure, it is suggested that a water pressure regulator be installed. The 200 series models covered in this manual do not come with water pressure regulators as standard equipment. Please notify Jackson if you have any questions.

Do not confuse static pressure with flow pressure. Static pressure is the line pressure in a "no flow" condition (all valves and services are closed). Flow pressure is the pressure in the fill line when the fill valve is opened during the cycle.

It is also recommended that a shock absorber (not supplied with the 200 series models) be installed in the incoming water line. This prevents line hammer (hydraulic shock), induced by the solenoid valve as it operates, from causing damage to the equipment.

STEAM LINE CONNECTION: The steam machines come with lines by which the source steam needs to be connected. Connect all steam lines to the machine as all applicable codes provide. See machine data plate for information concerning steam flow pressure.

CHEMICAL DISPENSING EQUIPMENT: The 200LT machine requires that a separate chemical feeder be connected to it to provide the required detergent, rinse agent, and sanitizer. This feeder needs to be able to operate against a head of 25 PSI and provide 1.79 ml of a 10% Chlorine sanitizer per minute.

SECTION 2: INSTALLATION/OPERATION INSTRUCTIONS

INSTALLATION INSTRUCTIONS (CONTINUED)

Mount all dispensing equipment at back of machine or on adjacent wall. Do not mount equipment on top or front of machine.

A fuse block is provided and located at the rear of the control box for electrical power connection and will provide line voltage (208/230V) during sixty (60) second time cycle. Properly rated fuses must be installed into fuse block for power connection. Install dispensing equipment power leads to fuse block in control box. Route wires to fuse block through 1/2" conduit hole provided in rear of control box. Install properly rated fuses not to exceed 2.5 ampere.

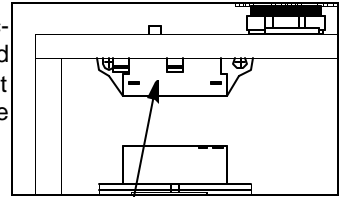

Fuse block location



NOTE: This fuse block will provide constant power during sixty (60) second time cycle.



WARNING: DO NOT MAKE ANY ELECTRICAL CONNECTIONS TO ANY INPUT OR LOAD CIRCUITS OF SOLID STATE TIMER OR ELSEWHERE IN CONTROL BOX OR TO SOLENOID OR MOTOR WIRING. CONSULT FACTORY FOR FURTHER INFORMATION.

PLUMBING CHECK: Slowly turn on the water supply to the machine after the incoming fill line and the drain line have been installed. Check for any leaks and repair as required. All leaks must be repaired prior to placing the machine in operation.

ELECTRICAL POWER CONNECTION: Electrical and grounding connections must comply with the applicable portions of the National Electrical Code ANSI/NFPA 70 (latest edition) and/or other electrical codes.

Disconnect electrical power supply and place a tag at the disconnect switch to indicate that you are working on the circuit.

The dishmachine data plate is located on the right side and to the front of the machine. Refer to the data plate for machine operating requirements, machine voltage, total amperage load and serial number.

To install the incoming power lines, open the control box. This will require taking a phillipshead screwdriver and removing the four (4) screws on the sides of the control box. Install 3/4" conduit into the pre-punched holes in the back of the control box. Route power wires and connect to power block and grounding lug. Install the service wires (L1, L2, and L3 (3 phase only)) to the appropriate terminals as they are marked on the terminal block. Install the grounding wire into the lug provided. Tighten the connections. It is recommended that "DE-OX" or another similar anti-oxidation agent be used on all power connections.

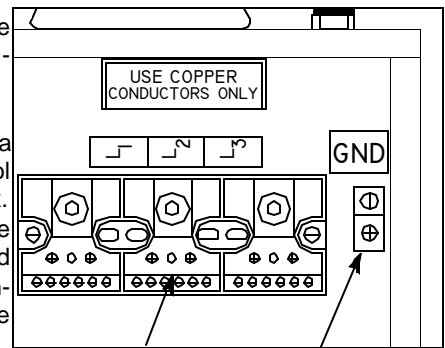

Power Block Connection

Ground Lug

VOLTAGE CHECK: Ensure that the power switch is in the OFF position and apply power to the dishmachine. Check the incoming power at the terminal block and ensure it corresponds to the voltage listed on the data plate. If not, contact a qualified service agency to examine the problem. Do not run the dishmachine if the voltage is too high or too low. Shut off the service breaker and mark it as being for the dishmachine. Advise all proper personnel of any problems and of the location of the service breaker. Replace the control box cover and tighten down the screws.

DETERGENT CONTROL

Detergent usage and water hardness are two factors that contribute greatly to how efficient your dishmachine will operate. Using detergent in the proper amount can become, in time, a source of substantial savings. A qualified water treatment specialist can tell you what is needed for maximum efficiency from your detergent, but you should still know some basics so you'll understand what they are talking about.

First, you must understand that hard water greatly effects the performance of the dishmachine. Water hardness is the amount of dissolved calcium and magnesium in the water supply. The more dissolved solids in the water, the greater the water hardness. Hard water works against detergent, thereby causing the amount of detergent required for washing to increase. As you use more detergent, your costs for operating the dishmachine will increase and the results will decrease. The solids in hard water also may build-up as a scale on wash and rinse heaters, decreasing their ability to heat water. Water temperature is important in removing soil and sanitizing dishes. If the water cannot get hot enough, your results may not be satisfactory. This is why Jackson recommends that if you have installed the machine in an area with hard water, that you also install some type of water treatment equipment to help remove the dissolved solids from the water before it gets to the dishmachine.

Second, hard water may have you adding drying agents to your operating cycle to prevent spotting, when the real problem is deposited solids on your ware. As the water evaporates off of the ware, the solids will be left behind to form the spotting and no amount of drying agent will prevent this. Again, using treated water will undoubtedly reduce the occurrences of this problem.

Third, treated water may not be suitable for use in other areas of your operation. For instance, coffee made with soft water may have an acid or bitter flavor. It may only be feasible to install a small treatment unit for the water going into the dishmachine itself. Discuss this option with your qualified water treatment specialist.

Even after the water hardness problems have been solved, there still must be proper training of dishmachine operators in how much detergent is to be used per cycle. Talk with your water treatment specialist and detergent vendor and come up with a complete training program for operators. Using too much detergent has as detrimental effects as using too little. The proper amount of detergent must be used for job. It is important to remember that certain menu items may require extra detergent by their nature and personnel need to be made aware of this. Experience in using the dishmachine under a variety of conditions, along with good training in the operation of the machine, can go a long way in ensuring your dishmachine operates as efficiently as possible.

Certain dishmachine models require that chemicals be provided for proper operation and sanitization. Some models even require the installation of third-party chemical feeders to introduce those chemicals to the machine. Jackson does not recommend or endorse any brand name of chemicals or chemical dispensing equipment. Contact your local chemical distributor for questions concerning these subjects.

Some dishmachines come equipped with integral solid detergent dispensers. These dispensers are designed to accommodate detergents in a certain sized container. If you have such a unit, remember to explain this to your chemical distributor upon first contacting them.

As explained before, water temperature is an important factor in ensuring that your dishmachine functions properly. The data plate located on each unit details what the minimum temperatures must be for either the incoming water supply, the wash tank and the rinse tank, depending on what model of dishmachine you have installed. These temperatures may also be followed by temperatures that Jackson recommends to ensure the highest performance from you dishmachine. However, if the minimum requirements are not met, the chances are your dishes will not be clean or sanitized. Remember, a dish can look clean, but it may not be sanitized. Instruct your dishmachine operators to observe the required temperatures and to report when they fall below the minimum allowed. A loss of temperature can indicate a much larger problem such as a failed heater or it could also indicate that the hot water heater for your operation is not up to capacity and a larger one may need to be installed.

There are several factors to consider when installing your dishmachine to ensure that you get the best possible results from it and that it operates at peak efficiency for many years. Discuss your concerns with your local chemical distributor and water treatment specialist before there is a problem.

SECTION 2: INSTALLATION/OPERATION INSTRUCTIONS

OPERATION INSTRUCTIONS

PREPARATION: Before proceeding with the start-up of the unit, verify the following:

1. The pan strainers and pump suction strainer are in place and are clean.
2. The overflow tube and o-ring are installed.
3. That the wash and rinse arm assemblies are secured into place and that their endcaps are tight. The wash and rinse arm assemblies should rotate freely.

POWER UP: To energize the unit, turn on the power at the service breaker. The voltage should have been previously verified as being correct. If not, the voltage will have to be verified.



NOTE: UNLESS OTHERWISE SPECIFIED IN THESE INSTRUCTION, ENSURE THAT THE MANUAL MODE SWITCH IS IN THE "OFF" POSITION BEFORE PROCEEDING WITH ANY OF THE FOLLOWING STEPS.

FILLING THE WASH TUB: Place the power switch into the ON position. Then place the cycle mode switch in the AUTO position. The machine should fill automatically and shut off when the appropriate level is reached (just below the pan strainer). Verify that the drain stopper is preventing the wash tub water from pouring out excessively. There may be some slight leakage from the drain hole. Verify that there are no other leaks on the unit before proceeding any further. The wash tub must be completely filled before operating the wash pump to prevent damage to the component. Once the wash tub is filled, the unit is ready for operation.

WARE PREPARATION: Proper preparation of ware will help ensure good results and less re-washes. If not done properly, ware may not come out clean and the efficiency of the dishmachine will be reduced. It is important to remember that a dishmachine is not a garbage disposal and that simply throwing unscrapped dishes into the machine simply defeats the purpose altogether of washing the ware. Scraps should be removed from ware prior to being loaded into a rack. Pre-rinsing and pre-soaking are good ideas, especially for silverware and casserole dishes. Place cups and glasses upside down in racks so that they do not hold water during the cycle. The dishmachine is meant not only to clean, but to sanitize as well, to destroy all of the bacteria that could be harmful to human beings. In order to do this, ware must be properly prepared prior to being placed in the machine.

DAILY MACHINE PREPARATION: Refer to the section entitled "PREPARATION" at the top of this page and follow the instructions there. Afterwards, check that all of the chemical levels are correct and/or that there is plenty of detergent available for the expected workload.

WARM-UP CYCLES: For a typical daily start-up, it is probably a good idea to run the machine through 3 cycles to ensure that all of the cold water is out of the system and to verify that the unit is operating correctly. To cycle the machine, ensure that the power is on, the cycle mode switch is in AUTO and that the tub has filled to the correct level. Lift the doors and the cycle light will illuminate. When the light goes out, close the doors, the unit will start, run through the cycle, and shut off automatically. Repeat this two more times. The unit should now be ready to proceed with the washing of ware.

WASHING A RACK OF WARE: To wash a rack, open the doors completely (being careful for hot water that may drip from the doors) and slide the rack into the unit. Close the doors and the unit will start automatically. Once the cycle is completed, open the door (again watching for the dripping hot water) and remove the rack of clean ware. Replace with a rack of soiled ware and close the doors. The process will then repeat itself.

OPERATIONAL INSPECTION: Based upon usage, the pan strainers may become clogged with soil and debris as the work-day progresses. Operators should regularly inspect the pan strainers to ensure they have not become clogged. If the strainers do, it will reduce the washing capability of the machine. Instruct operators to clean out the pan strainers at regular intervals or as required by work load.

SECTION 2: INSTALLATION/OPERATION INSTRUCTIONS

OPERATION INSTRUCTIONS (CONTINUED)

SHUTDOWN AND CLEANING: Secure steam flow to the machine in accordance with applicable codes and procedures. Steam flow must be secured prior to cleaning the inside of the machine. At the end of the workday, close the doors. When the unit completes the cycle, turn the power switch to the OFF position and open the doors. Manually remove the drain stopper from the tub and allow the tub to drain (NOTE: the wash tank water will be hot so caution is advised). Once the wash tub is drained, remove the pan strainers and the pump suction strainer. Remove soil and debris from the strainers and set to the side. Remove the wash and rinse arm assemblies from their manifolds. Remove the endcaps and flush the arms with water. Use a brush to clean out the inside of the arms. If the nozzles appear to be clogged, use a toothpick to remove the obstruction. Wipe the inside of the unit out, removing all soil and scraps. Reassemble the wash and rinse arm assemblies and replace. NOTE: When replacing the arms, do not use any tools to do so, the assemblies should secure by hand. Reinstall the strainers and close the doors.

SECTION 3: PREVENTATIVE MAINTENANCE

PREVENTATIVE MAINTENANCE

The dishmachines covered in this manual are designed to operate with a minimum of interaction with the operator. However, this does not mean that some items will not wear out in time. Jackson highly recommends that any maintenance and repairs not specifically discussed in this manual should be performed by **QUALIFIED SERVICE PERSONNEL ONLY**. Performing maintenance on your dishmachine may void your warranty if it is still in effect, so if you have a question or concern, do not hesitate to contact one of the **QUALIFIED SERVICE AGENCIES** listed in the back of this manual.

There are many things that operators can do to prevent catastrophic damage to the dishmachine. One of the major causes of component failure has to do with prescrapping procedures. A dishmachine is not a garbage disposal; any large pieces of material that are put into the machine shall remain in the machine until they are either broken up (after spreading out on your ware!) or physically removed. Strainers are installed to help catch debris, but they do no good if they are clogged. Have operators regularly inspect the pan strainers to ensure (1) that they are free of soil and debris and (2) they are laying flat in the tub.

When cleaning out strainers, do **NOT** beat them on waste cans. The strainers are made of metal and can be forgiving; but once severe damage is done, it is next to impossible for the strainer to work in the way it was designed to. Wipe out strainers with a rag and rinse under a faucet if necessary. For stubborn debris, a toothpick should be able to dislodge any obstructions from the perforations. Always ensure that strainers are placed back in the machine before operation and that they lay flat in the tub.

You may wish to learn more about how your water hardness will effect the performance of your machine. Hard water makes dishmachines work harder and decreases efficiency.

Again, it is important to remind operators that trying to perform corrective maintenance on the dishmachine could lead to larger problems or even cause harm to the operator. If a problem is discovered; secure the dishmachine using proper shut down procedures as listed in this manual and contact a **QUALIFIED SERVICE AGENCY**.

Some problems, however, may have nothing to do with the machine itself and no amount of preventative maintenance is going to help. A common problem has to do with temperatures being too low. Verify that the water temperatures coming to your dishmachine match the requirements listed on the machine data plate. There can be a variety of reasons why your water temperature could be too low and you should discuss it with a **QUALIFIED SERVICE AGENCY** to determine what can be done.

By following the operating and cleaning instructions in this manual, you should get the most efficient results from your machine. As a reminder, here are some steps to take to ensure that you are using the dishmachine the way it was designed to work:

1. Ensure that the water temperatures match those listed on the machine data plate.
2. Ensure that all strainers are in place before operating the machine.
3. Ensure that all wash and/or rinse arms are secure in the machine before operating.
4. Ensure that drains are closed/sealed before operating.
5. Remove as much soil from dishes by hand as possible before loading into racks.
6. Do not overfill racks.
7. Ensure that glasses are placed upside down in the rack.
8. Ensure that all chemicals being injected to machine have been verified as being at the correct concentrations.
9. Clean out the machine at the end of every workday as per the instructions in the manual.
10. Always contact a **QUALIFIED SERVICE AGENCY** whenever a serious problem arises.
11. Follow all safety procedures, whether listed in this manual or put forth by local, state or national codes/regulations.

SECTION 4: TROUBLESHOOTING SECTION

COMMON PROBLEMS



WARNING: Inspection, testing and repair of electrical equipment should only be performed by a qualified service technician. Many of the tests require that the unit have power to it and live electrical components be exposed. **USE EXTREME CAUTION WHEN TESTING THE MACHINE.**

Problem: Dishmachine will not run. No power to the unit.

1. Service breaker tripped. Reset breaker. If breaker trips again, immediately contact an electrician.
2. Incoming power lines not installed in control box. Install power lines.
3. Incoming power lines connections not tightened. Tighten connections.

Problem: Dishmachine will not run. There is power to the unit.

1. Door switch shorted out or is disconnected. Check to ensure door switch wires are connected correctly. If so, replace door switch.
2. Faulty "ON/OFF" switch. Ensure switch is wired properly. If so, replace switch.
3. Solid state timer, faulty. Check wiring, replace if necessary.

Problem: Machine runs, but there is no water.

1. No water supply to the machine. Check to ensure that all water valves are open and that water is being supplied to the machine at 20 ± 5 PSI.
2. Incoming water supply solenoid not operating. Check to ensure that valve is wired correctly. If so, replace valve.

Problem: Dishmachine fills continuously, even with no power to the machine.

1. Incoming water supply solenoid not operating. (Stuck Open) Check to ensure that valve is wired correctly. If so, replace valve.

Problem: Dishmachine fills continuously, only when the power is on.

1. Incoming water supply solenoid not operating. Check to ensure that valve is wired correctly. If so, replace valve.
2. Faulty solid state timer. Check wiring, replace if necessary.
3. Shorted out ON/FILL switch. Check the voltage across the switch. If the voltage is incorrect, replace the switch.
4. Shorted/defective liquid level control board or probe. Check voltage going to each component and ensure they are wired correctly. If satisfactory, replace the defective part.

Problem: Dishmachine runs with the door open.

1. Door switch shorted out/wired incorrectly. Check the wiring of the door switch. If correct, replace the door switch.
2. Faulty wash relay (wash relay welded closed). Turn machine off, if wash relay doesn't release, replace contactor.

Problem: Low wash water pressure.

1. Water level is too low. Check to ensure that the drain stopper is in and has an O-ring. Check to ensure that the LLC board and probe are functioning properly.
2. Pump intake strainer is clogged. Remove and clean strainer.
3. Wash arms (nozzles) are clogged. Remove wash arms and clean.

Problem: Low wash water pressure.

1. Pump impeller worn or broken. Replace pump.
2. Obstruction in wash arm or wash arm nozzle. Remove and clean.
3. Wash arm not secured into manifold. Wash arm assembly should lock into into place.



WARNING: Inspection, testing and repair of electrical equipment should only be performed by a qualified service technician. Many of the tests require that the unit have power to it and live electrical components be exposed. **USE EXTREME CAUTION WHEN TESTING THE MACHINE.**

Problem: Water temperature is less than required.

1. Low incoming water temperature. Compare to data plate.
2. No power to heater. Check wiring, replace if necessary.
3. Thermostat out of adjustment. Adjust or replace thermostat as required.

SECTION 5: SERVICE PROCEDURES

SECTION 5: SERVICE PROCEDURES

These dishmachines are equipped with electrical solenoid valves to allow for automatic fill and rinse. These valves are designed to specific tolerances and design aspects that must be met in order to function properly.

Jackson offers repair kits for replacing some of the wear items associated with solenoid valves which will allow you to save money in that replacement of these parts can take place *without* removing the solenoid valve from the plumbing assembly.

The instructions provided here are for maintenance personnel only. Unauthorized persons should not attempt any of the steps contained in these instructions.

Warning: many of the instructions and steps within this document require the use of tools. Only authorized personnel should ever perform any maintenance procedure on the dishmachine!

PREPARATION

1. Power must be secured to the unit at the service breaker. Tag or lock out the service breaker to prevent accidental or unauthorized energizing of the machine.

2. Ensure that incoming water to the machine is secured either by use of a shut-off valve or disconnecting the incoming water line.

TOOLS REQUIRED

The following tools will be needed to perform this maintenance evolution:

1. Small flathead screwdriver
2. Medium flathead screwdriver
3. Needle nose pliers
4. 5/16" nutdriver
5. Channel locks
6. 12" pipe wrench

TIME REQUIRED

It is estimated that it will take (1) person twenty minutes to perform this task, not including all of the items indicated in the section entitled "PREPARATION".

IMPORTANT NOTES

1. Read these instructions thoroughly before attempting this maintenance evolution. Become familiar with the parts and what actions need to be taken. This will save time in the long run!

2. The procedures demonstrated in this manual are shown being performed on an AJ-44 rack conveyor dishmachine. The actual maintenance steps, however, apply to any Parker style solenoid valve found on a Jackson dishmachine.

RINSE SOLENOID VALVE REPAIR PARTS KIT

STEPS

1. Remove the top screw with the 5/16" nutdriver. Remove the screw and the data plate and set to the side.



Removing the top screw

2. With the top screw and data plate removed, grasp the solenoid coil and gently pull up. The coil should slide up, allowing you to remove it from the valve bonnet. If you are wanting to replace the coil, continue on with Step 3. If you are wanting to replace some of the internal components of the valve, proceed to step 12.



Removing the coil

3. **NOTE:** Replacing the solenoid coil requires working with the wiring of your machine. It is important that all wiring maintenance be performed by qualified personnel. Always verify the wiring steps presented in this instruction with the schematic that shipped with the unit. A current schematic can also be found in the unit's installation manual. Before beginning any step that involves working with wiring, ensure that the steps located in the section entitled "Preparation" have been performed. Power must be secured to the machine at the service breaker. Failure to do so could result in severe injury to maintenance personnel.

RINSE SOLENOID VALVE REPAIR PARTS KIT (CONTINUED)



Prying open the coil wire cover

4. When replacing the coil, ensure that when removing the coil wire cover that care is taken not to damage the wires inside. Using the medium flathead screwdriver, gently use it to open the cover enough to where it could be pulled off.

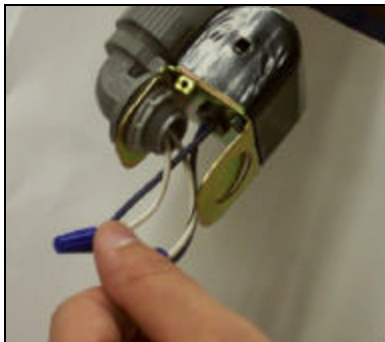

Straightening the wires

5. Once the coil wire cover has been removed and set to the side, take the internal wires and pull them out straight.



Removing the wire nuts

6. Remove the wire nuts from the wires and separate them.



Loosening the conduit nut

7. Using a pair of channel locks, gently loosen the conduit retaining ring for the conduit nut. Once it is loosened, use your fingers to unscrew and remove it.

8. Pull the conduit away and discard the bad coil. Take the new coil and attach the conduit, reinstall & tighten the conduit nut, and pull the wires through so that you will be able to wire the valve back up.

9. Reconnect the wires from the conduit to the wires from the solenoid as they had been connected previously. Ensure that the wire nuts are on tight.

10. Slide the coil wire cover back on, taking care not to damage the wires.

11. If you are done performing maintenance on the valve, continue on to step 23. Otherwise, please go on to step 12.L



Loosening the valve bonnet

12. To remove the valve bonnet, grasp it with the jaws of the pipe wrench and turn to the left. **Note:** on some models you may have to remove the valve in order to perform this and any further steps. Be careful not to damage the plumbing assembly. Only use the pipe wrench enough to where you can spin the valve bonnet off with your hand.

SECTION 5: SERVICE PROCEDURES

RINSE SOLENOID VALVE REPAIR PARTS KIT (CONTINUED)



Removing the valve bonnet

13. Slowly remove the valve bonnet. **Note:** The spring for the plunger is located directly under the bonnet and may come free if you are not careful. Remove the plunger, spring and valve bonnet and place to the side.



Removing the diaphragm

17. Remove the diaphragm retainer and then the diaphragm itself. Many problems associated with a solenoid valve can be traced to a clogged pilot port in the diaphragm.



Removing the O-ring

14. Remove the O-ring and inspect it. If it has any tears or cuts or excessive flat spaces, it should be replaced.

15. Examine the threads for the valve bonnet. Check them for scoring or signs of damage. Take a cloth and clean them out to remove any foreign particles that might get lodged in the threads and cause a leak. Severely damaged threads should not be repaired; instead it is recommended that the entire valve should be replaced. These instructions do not provide information on replacing the solenoid valve.

16. **Note:** Even though an O-ring may not appear damaged, it is a good idea to go ahead and replace it if you have a new one. This will help ensure that your valve remains leak-free in the future!

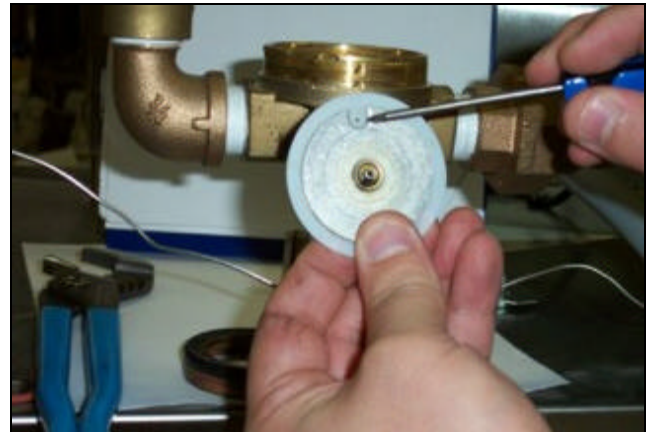

Pointing out the extension hole

18. As indicated in the photo above, the extension hole can become clogged. If it is difficult to clean out, you can use a heated straight pin to push through the hole. The center hole, the pilot port, must also be clear. If the diaphragm is torn or bent in any way, it must be replaced.

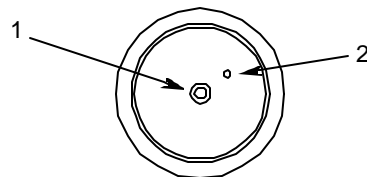

Diaphragm showing (1) pilot port and (2) extension hole

RINSE SOLENOID VALVE REPAIR PARTS KIT (CONTINUED)



Removing the screen retainer

19. Using the small flathead screwdriver, lift out the screen retainer. Verify that the holes in it are free of clogs and debris.



Removing the mesh strainer screen

20. Again using the small flathead screwdriver, carefully remove the mesh screen from inside the valve body. The screen should be taken and rinsed out to remove any debris fouling it.

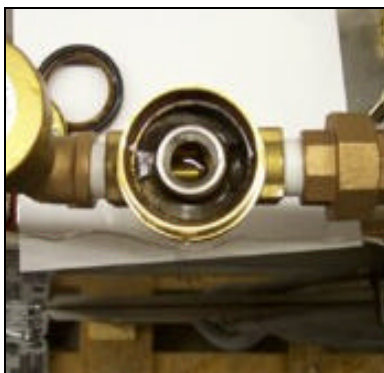

View inside the solenoid valve body

21. With the mesh screen removed, look down into the valve and verify it is not clogged. Remove any foreign objects from the valve body that would obstruct flow.

22. Reassemble the valve, reversing the steps needed to take it apart. Replace defective replacement parts with new parts from ordered kits. Ensure that components are sufficiently tightened to prevent leakage.

AFTER MAINTENANCE ACTIONS

Reconnect the incoming water (if disconnected) and turn on. Then restore power to the unit. Run the unit for at least 10 minutes to ensure there are no leaks. If any problems arise please contact your Jackson representative.

SPECIAL PARTS

Solenoid Valve Plunger Kit

Includes plunger and spring

Part number 06410-003-07-40

Solenoid Valve Diaphragm Kit

Includes diaphragm and o-ring

Part number 06401-003-07-42 (3/4" NPT)

Solenoid Valve 24 Volt Coil and Housing

Part number 04810-100-06-18

Complete Solenoid Valve

Part number 04810-100-01-40 (3/4", 24 Volt)

SECTION 5: SERVICE PROCEDURES

VACUUM BREAKER REPAIR PARTS KIT

These dishmachines are equipped with vacuum breakers to serve as back-flow prevention devices. ASSE requirements specify what type of back-flow prevention is necessary on dishmachines. Vacuum breakers, unlike air gaps, have certain parts that have specific tolerances and design aspects that must be met in order to function properly.

Jackson offers repair kits for replacing some of the wear items associated with vacuum breakers which will allow you to save money in that replacement of these parts can take place *without* removing the vacuum breaker from the plumbing assembly.

The instructions provided here are for maintenance personnel only. Unauthorized persons should not attempt any of the steps contained in these instructions.

Warning: many of the instructions and steps within this document require the use of tools. Only authorized personnel should ever perform any maintenance procedure on the dishmachine!

PREPARATION

1. Power must be secured to the unit at the service breaker. Tag or lock out the service breaker to prevent accidental or unauthorized energizing of the machine.

2. Ensure that incoming water to the machine is secured either by use of a shut-off valve or disconnecting the incoming water line.

TOOLS REQUIRED

The following tools will be needed to perform this maintenance evolution:

1. Small flathead screwdriver
2. Needle nose pliers

TIME REQUIRED

It is estimated that it will take (1) person twenty minutes to perform this task, not including all of the items indicated in the section entitled "PREPARATION".

IMPORTANT NOTES

1. Read these instructions thoroughly before attempting this maintenance evolution. Become familiar with the parts and what actions need to be taken. This will save time in the long run!

STEPS

1. **Note:** These instructions only apply to vacuum breakers (1/2" NPT and 3/4" NPT) as pictured below. The repair kits indicated in these instructions will only work on those style of back-flow preventers. If you have a machine with a different style of vacuum breaker, contact your Jackson representative about replacement components.



Vacuum breaker

2. **Note:** Even though the photos in these instructions show a vacuum breaker that has been removed from the plumbing assembly, these maintenance steps could be performed with it installed so long as the requirements in the section entitled "PREPARATION" have been met.

3. Remove the top cap by gripping firmly and turning to the left. The cap should come off after a few turns.



Removing the cap

4. Set the cap to the side.

5. Using the needle nose pliers, gently lift out the plunger and set to the side. Examine the brass seating surface inside the vacuum breaker. The plunger is required to sit flat on this surface so it must be free of defects, imperfections and the like. If there is debris, remove it. If it is chipped or cracked then the vacuum breaker must be replaced. Failure to do so may result in the vacuum breaker not working according to its design and could result in damage to the dishmachine.

VACUUM BREAKER REPAIR PARTS KIT (CONTINUED)

Removing the plunger

6. Your repair kit comes with a new plunger. Examine the old one and ensure that the mating surface is not damaged or cut. Also inspect the rubber seal on the top of the plunger to ensure it is in good condition and not torn.

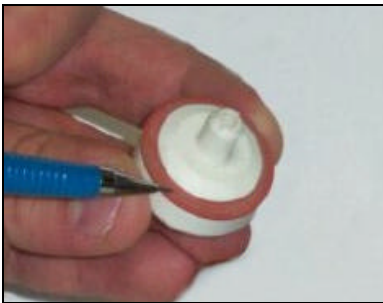

Examining the seal ring on the plunger



Examining the plunger seating surface

7. If any of these conditions are present, replace the old plunger with the new one from your kit. Verify that the new plunger is also free from defects. If it is not, contact your Jackson representative immediately.

8. The plunger should drop into the vacuum breaker and seat. Ensure it is not flipped upside down (the orange seal ring should be up towards the top of the vacuum breaker).

9. Pick up the cap and examine it. With a soft towel, remove any grit, grime or debris that may have gotten caught in the threads of both the cap retainer or the vacuum breaker body. There is an O-ring that should be present on the cap retainer as well. Regardless of the condition of the plunger, this O-ring should be replaced once the cap is removed. Using a small flathead screwdriver, remove the old O-ring.

10. With the new O-ring in place, screw the cap back on the vacuum breaker body. The cap needs to only be hand tight (snug).



Replacing the O-ring

AFTER MAINTENANCE ACTIONS

1. Reconnect the incoming water (if disconnected) and turn on. Then restore power to the unit. Run the unit for at least 10 minutes to ensure there are no leaks. If any problems arise please contact your Jackson representative.

SPECIAL PARTS

To order the kit with components and instructions:

For 3/4" NPT order 06401-003-06-24

SECTION 5: SERVICE PROCEDURES

RINSE REGULATING THERMOSTAT REPLACEMENT

Many dishmachines come with integral booster tanks to ensure proper temperature of the final rinse. Jackson has predominantly used two manufacturers of thermostats, EGO and Stemco. These instructions are for use with kit 06401-003-13-94, which is to replace an EGO rinse regulating thermostat with a Stemco brand.

Jackson offers all of the repair parts necessary for performing this task.

The instructions provided here are for maintenance personnel only. Unauthorized persons should not attempt any of the steps contained in these instructions.

Warning: many of the instructions and steps within this document require the use of tools. Only authorized personnel should ever perform any maintenance procedure on the dishmachine!

PREPARATION

1. Power must be secured to the unit at the service breaker. Tag or lock out the service breaker to prevent accidental or unauthorized energizing of the machine.

2. Ensure that incoming water to the machine is secured either by use of a shut-off valve or disconnecting the incoming water line.

3. The unit must be drained completely with the drain stopper removed (if applicable).

4. Remove any and all access covers.

TOOLS REQUIRED

The following tools may be needed to perform this maintenance evolution:

1. 3/8" Nutdriver
2. 7/16" Combination Wrench
3. Needlenose Pliers
4. Phillipshead Screwdriver
5. Flathead Screwdriver
6. Ratchet with 1/2" Socket

TIME REQUIRED

It is estimated that it will take (1) person sixty minutes to perform this task, not including all of the items indicated in the section entitled "PREPARATION".

IMPORTANT NOTES

1. Read these instructions thoroughly before attempting this maintenance task. Become familiar with the parts and what actions need to be taken. This will save time in the long run!

2. These instructions are shown using a Tempstar model dishmachine. However the steps provided should work for models such as the 200B as well.

STEPS

1. Some models, such as the Tempstar pictured below, will require that the thermostat bracket removed from the heater. Using a ratchet, extension and 1/2" socket, remove the nuts and lock washer holding the bracket on.



Removing the thermostat bracket/heater nuts.

2. With the thermostat and thermostat bracket safely out of the way, use a 7/16" combination wrench to loosen and then remove the imperial brass fitting holding the probe in.

3. Remove the wires from the old thermostat. It may be necessary to use the needlenose pliers to accomplish this.

4. Remove the thermostat bracket mounting nuts with the 7/16" nutdriver.



Removing the thermostat bracket.

RINSE REGULATING THERMOSTAT REPLACEMENT



Removing the imperial brass fitting.



Attaching the jumper wires.

5. Attach the jumper wires to the wires that you removed from the old thermostat.



Pulling the thermostat probe and fitting from the well.

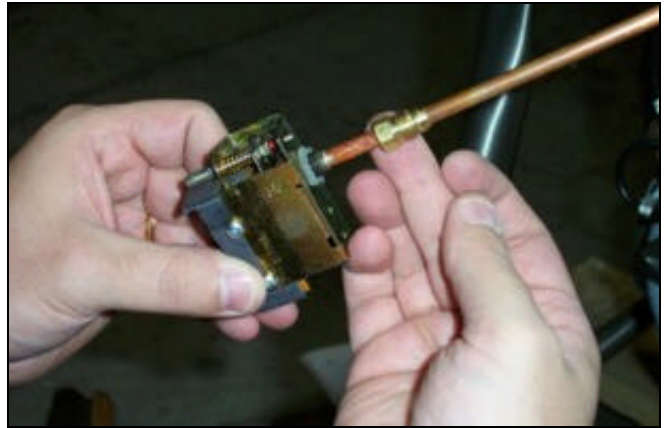

Sliding imperial fitting onto new thermostat.

6. Slide the new imperial brass fitting from your kit onto the new thermostat.



Removing the wires from the thermostat.



Putting the new thermostat in the well.

SECTION 5: SERVICE PROCEDURES

7. Insert the new thermostat/brass fitting combination into the well and tighten down the brass fitting by hand.



Tightening the brass fitting.

8. Use the 7/16" combination wrench to tighten down the brass fitting, while also positioning the new thermostat so that it does not hang over the heater.

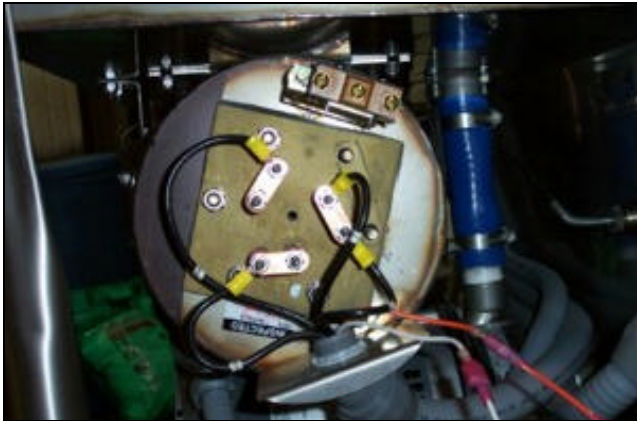

What the installed thermostat should look like (Tempstar).

9. Note: regardless of the unit this is being done to, the concept is to ensure that the thermostat cannot come into contact with the heater leads or interfere with the placement of any covers.

RINSE REGULATING THERMOSTAT REPLACEMENT



Removing the thermostat screws.

10. Use the phillipshead screwdriver to remove the attachment screws on the thermostat for the NORMALLY CLOSED and COMMON points.

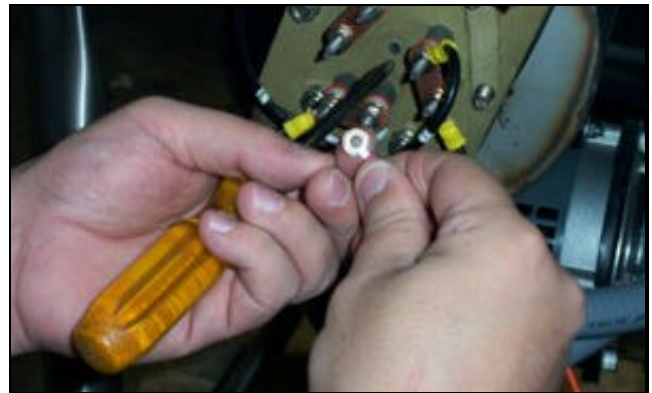

Fitting the jumper into the mounting cup.

11. Attach the ring ends of the jumpers to the cups/screws removed from the thermostat and attach them. The white jumper is to be connected to COMMON. The orange and white jumper is to be connected to NORMALLY CLOSED. Refer to your machine schematic if you have any questions regarding this.

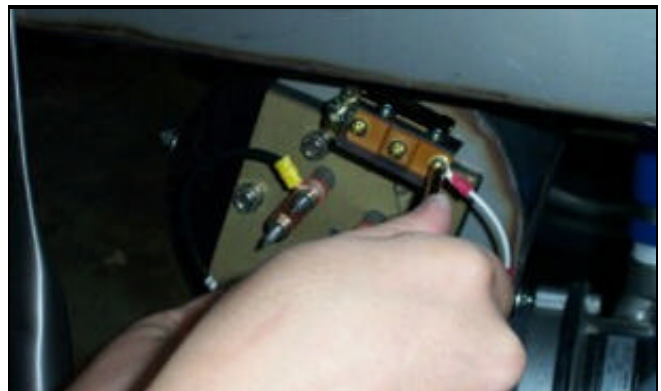

Securing jumpers to the thermostat.

RINSE REGULATING THERMOSTAT REPLACEMENT

12. Once both wires are attached, ensure that there is no excess hanging out where it could become pinched by any cover or such.

13. Replace the heater nuts (if removed) and torque down as required per the technical manual. Different models may have different torque specifications. Contact Jackson Technical Service if there are any questions regarding this.

Jackson MSC Inc. provides technical support for all of the dishmachines detailed in this manual. We strongly recommend that you refer to this manual before making a call to our technical support staff. Please have this manual with you when you call so that our staff can refer you, if necessary, to the proper page. Technical support is available from 8:00 a.m. to 5:00 p.m. (EST), Monday through Friday. Technical support is not available on holidays. Contact technical support toll free at 1-888-800-5672. Please remember that technical support is available for service personnel only.

AFTER MAINTENANCE ACTIONS



Calibrating the new thermostat.

Once the new thermostat is installed, it will be necessary to ensure that it operates at the required and appropriate ranges. The new thermostat has an adjustment that can be turned using a small flathead screwdriver. Several cycles will need to be run on the unit while observing the final rinse temperature. The thermostat needs to cycle so that the final rinse water meets the indicated minimums on the machine data plate for every cycle.

SPECIAL NOTES

Work performed on Jackson dishmachines by unauthorized or unqualified personnel may void the warranty. Before beginning this or any other maintenance evolution on a unit under warranty, you should contact a certified Jackson technician or Jackson Technical Service. You can find a list of qualified service agencies in the back of you unit's installation manual.

SPECIAL PARTS

Thermostat Replacement Kit: 06401-003-13-94*

*The kit contains a thermostat, imperial brass fitting, jumper wires and instructions.

CONTACT INFORMATION

SECTION 6: PARTS SECTION

CONTROL BOX ASSEMBLY

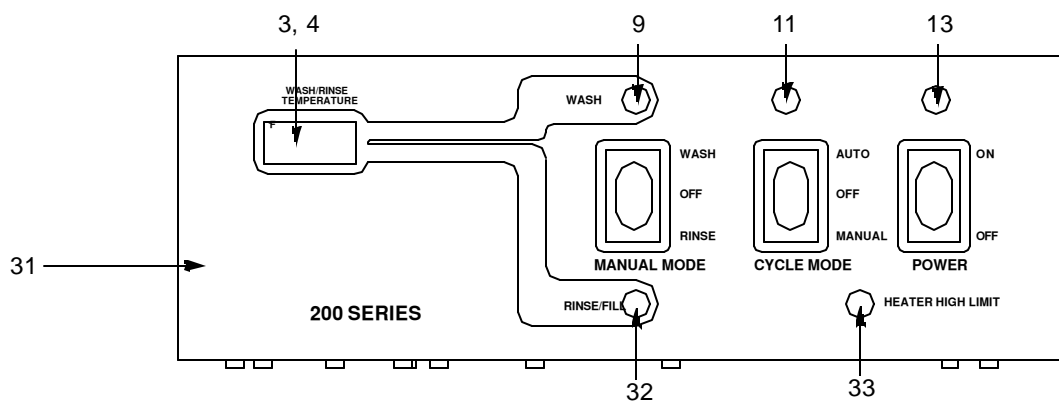
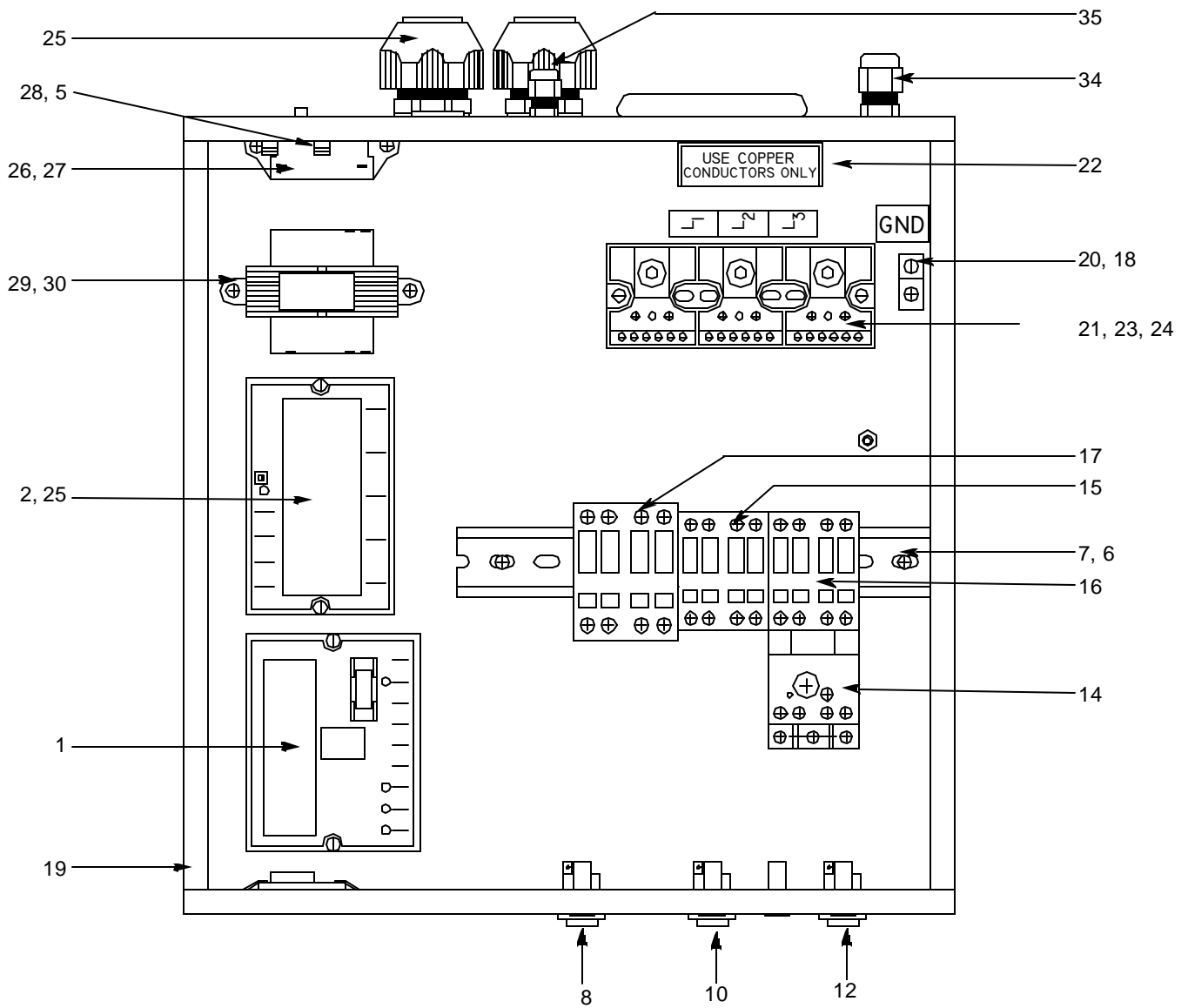

SECTION 6: PARTS SECTION

CONTROL BOX ASSEMBLY (CONTINUED)

ITEM	QTY	DESCRIPTION	Mfg. No.
1	1	Timer, Solid State	05945-307-07-93
2	1	Liquid Level Control, 2 Probe, 4 SEC	06680-200-01-93
3	1	Thermometer, LED with 21" & 89" Probe	06685-400-04-00
	1	Wash Probe, 19"	06685-400-06-00
	1	Rinse Probe, 87"	06685-400-07-00
4	2	Locknut, 10-24 S/S Hex with Nylon Insert	05310-373-01-00
5	1	Decal, Detergent Dispenser	09905-107-02-12
6	2	Screw, 10-32 x 3/8" Long Truss	05305-173-12-00
7	1	Din Rail, 9 11/16" Long	05700-001-26-97
8	1	Switch, SPDT 3 Position, WASH-OFF-RINSE	05930-302-03-41
9	1	Light, Amber Indicator 28 VAC	05945-504-02-90
10	1	Switch, SPDT 3 Position, AUTO-OFF-MANUAL	05930-301-49-00
11	1	Light, Green Indicator 28 VAC	05945-504-04-90
12	1	Switch, SPDT 2 Position, ON-OFF	05930-301-46-00
13	1	Light, Red Indicator 28 VAC	05945-504-01-90
14	1	Overload, 2.5-4 AMP Range (208-230V Models Only)	05945-111-68-41
14	1	Overload, 460V, 3 PH	05945-304-02-09
15	1	Relay, Wash Motor, 208-460V, 1PH & 3 PH	05945-109-03-09
16	1	Relay, Wash Heater, 208-230V, 1 PH (Not used on 200S)	05945-109-02-09
17	1	Relay, Rinse Heater, 208-230/460V (200B Only)	05945-109-01-09
18	1	Decal, Ground	09905-011-86-86
19	1	Control Box Weldment with Tric-nuts	05700-001-26-44
20	1	WireLug	05940-200-76-00
21	1	Decal, L1, L2, & L3	09905-101-12-66
22	1	Decals, Copper Conductors	09905-011-47-35
23	1	Block, 3 Pole Power Distribution	05945-603-01-66
24	2	Screw, 10-32 x 7/8" Fillister Head	05305-973-04-00
25	2	Fitting, 3/4" Straight Xtraflex	05975-205-46-44
26	4	Screw, 10-32 x 7/8" Fillister Head	05305-973-04-00
27	1	Relay, 24 VAC Coil	05945-301-07-40
28	1	Holder, Fuse #350 330	05920-401-03-14
29	1	Transformer, 60VA, 208/240V Class	05950-400-01-35
29	1	Transformer, 60VA, 460V	05950-400-02-35
30	2	Screw, 10-32 x 3/8" Long Truss	05305-173-12-00
31	1	Decal, Control Box	09905-101-00-00
32	1	Light, Blue Indicator 28 VAC	05945-504-05-90
33	1	Light, Clear Indicator 28 VAC	05945-504-03-90
34	1	Fitting, Liquid Tite, Temperature Probe	05975-205-43-00
35	1	Connector, Liquid Tite Fitting, .27 to .48	05975-011-59-50

Platform, with Tricnuts
05700-001-26-89

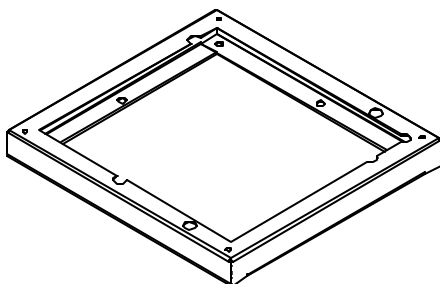

Cover, Control Box
05700-001-22-09

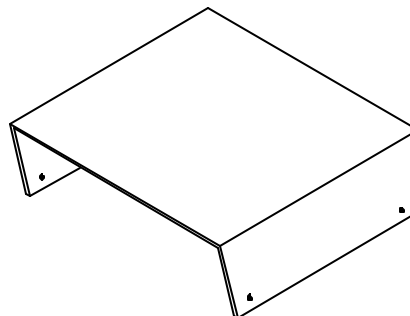

Spacer, Control Box
09515-800-94-00

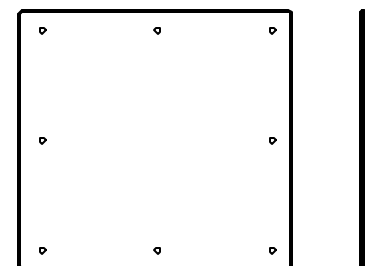

HOOD ASSEMBLY (SINGLE PIECE WELDMENT)

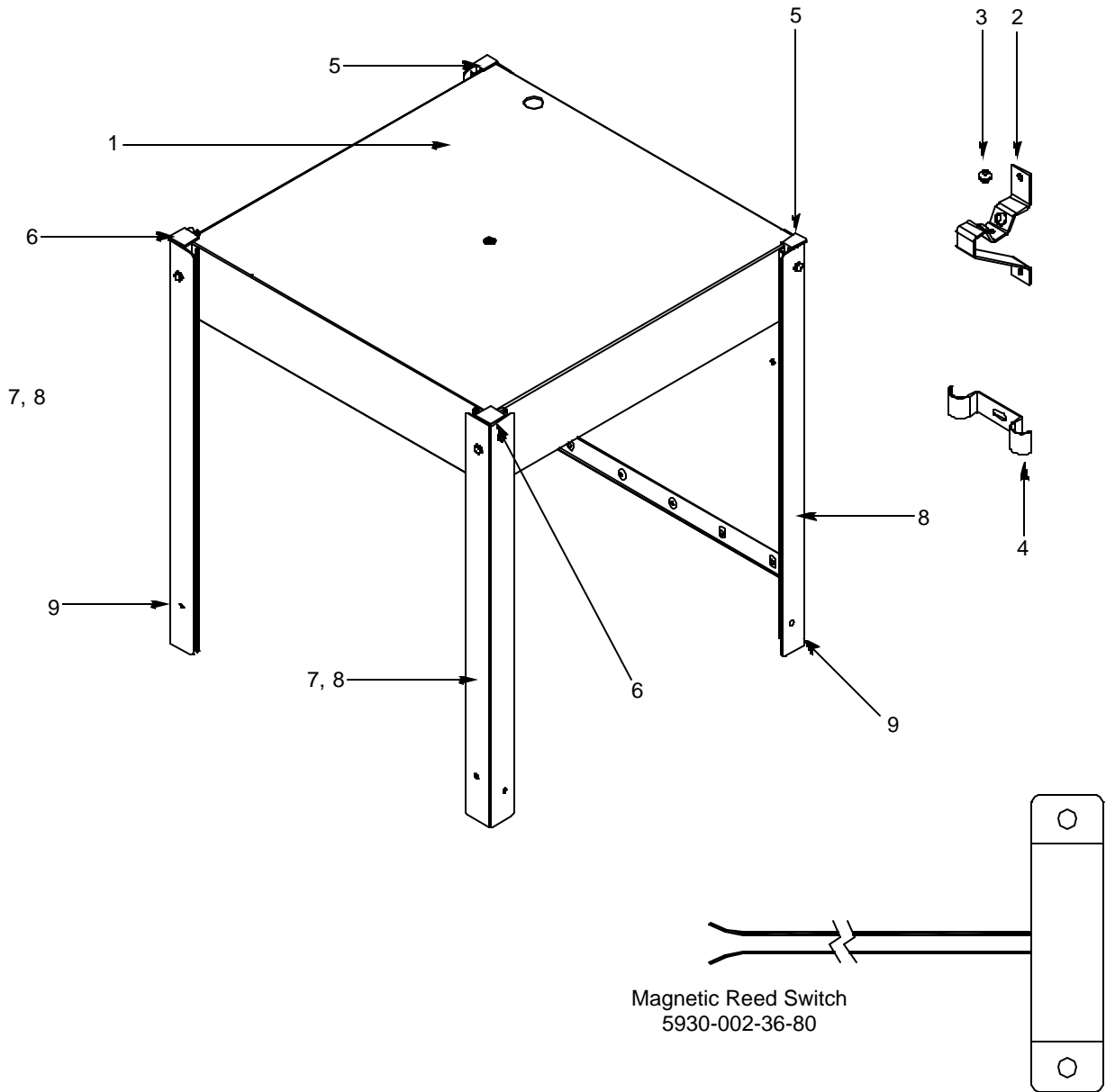

ITEM	QTY	DESCRIPTION	Mfg. No.
1	1	Hood, Weldment	05700-001-23-22
2	2	Bracket, Cantilever Support	05700-031-88-00
3	6	Wear Button 1/2" Dia.	05700-011-88-01
4	1	Clamp, Double	05700-002-23-89
5	2	Hood Spacer, Rear	05700-001-23-06
6	2	Hood Spacer, Front	05700-001-23-07
7	2	Front Door Rail	05700-001-20-82
8	4	Hood Support	05700-001-20-83
9	6	Hood Spacer, Bottom (Not shown)	05700-001-23-05

CANTILEVER ARM/DOOR ASSEMBLIES

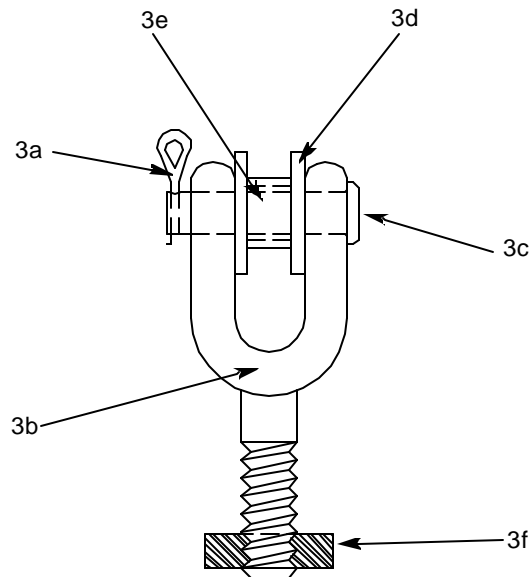
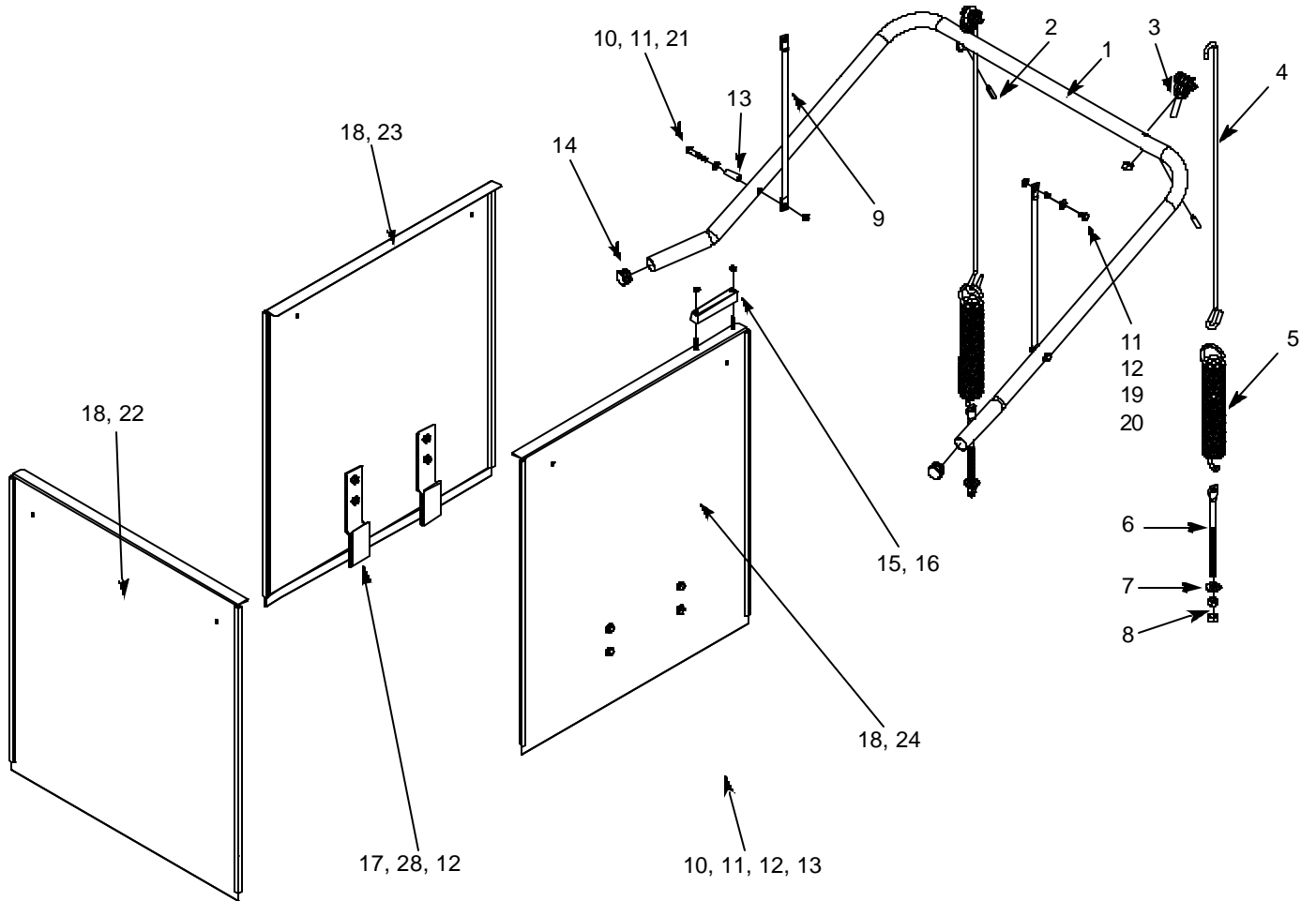

CANTILEVER ARM/DOOR ASSEMBLIES (CONTINUED)

ITEM	QTY	DESCRIPTION	Mfg. No.
1	1	Cantilever Arm	05700-001-21-00
2	2	Spring Pin, 1/4" x 1 1/8"	05315-407-06-00
3	2	Yoke Assembly	05700-000-75-77
3a	1	Cotter Pin	05315-207-01-00
3b	1	Yoke	05700-000-75-78
3c	1	Clevis Pin, 5/16" x 1 3/8"	05315-700-01-00
3d	2	Nylon Washer	05311-369-03-00
3e	1	Bushing	03120-100-03-00
3f	2	Locknut, 3/8"-16 S/S Hex Center	05310-256-04-00
4	2	Rod, Spring	05700-001-28-18
5	2	Spring	05340-109-02-00
6	2	Bolt, Cantilever Hanger Eye 3/8"-16	05306-956-05-00
7	2	Washer, 3/8" ID x 7/8" OD S/S	05311-176-02-00
8	4	Nut, 3/8"-16 S/S Hex	05310-276-01-00
9	2	Connector, Cantilever Arm	05700-001-25-42
10	2	Screw, 1/4"-20 x 1 1/2" Long S/S	05305-274-23-00
11	4	Washer, 1/4" S/S	05311-174-01-00
12	16	Locknut, 1/4"-20 S/S Hex with Nylon Insert Low Profile	05310-374-02-00
13	2	Sleeve, Cantilever Arm	05700-000-85-69
14	2	Plug, Cantilever Arm	05340-011-35-00
15	1	Magnet, Reed Switch	05930-002-68-53
16	2	Locknut, 8-32 S/S Hex with Nylon Insert	05310-272-02-00
17	4	Door Stop	05700-021-38-88
18	6	Door, Guides	05330-600-02-00
19	2	Screw, 1/4"-20 x 3/4" Long S/S	05305-274-04-00
20	2	Sleeve, Lever & Wrap	05700-001-25-41
21	8	Locknut, 1/4"-20 S/S Hex with Nylon Insert	05310-374-01-00
22	1	Door, Front (Complete Assembly)	05700-001-25-72
22A	1	Door Only, Front	05700-001-20-98
22B	1	Operation Decal	09905-101-11-12
23	1	Door, Left Side (Complete Assembly)	05700-001-25-73
23A	1	Door Only, Left Side	05700-001-20-99
24	1	Door, Right Side (Complete Assembly)	05700-001-25-74
25	1	Door Connector Wrap	05700-001-22-73
26	6	Door Connector Wrap Spacer	05700-001-23-12
27	6	Screw, 1/4"-20 x 1 1/8" Long S/S	05305-274-21-00
28	8	Screw, 1/4"-20 x 3/8" Long S/S	05305-179-02-00

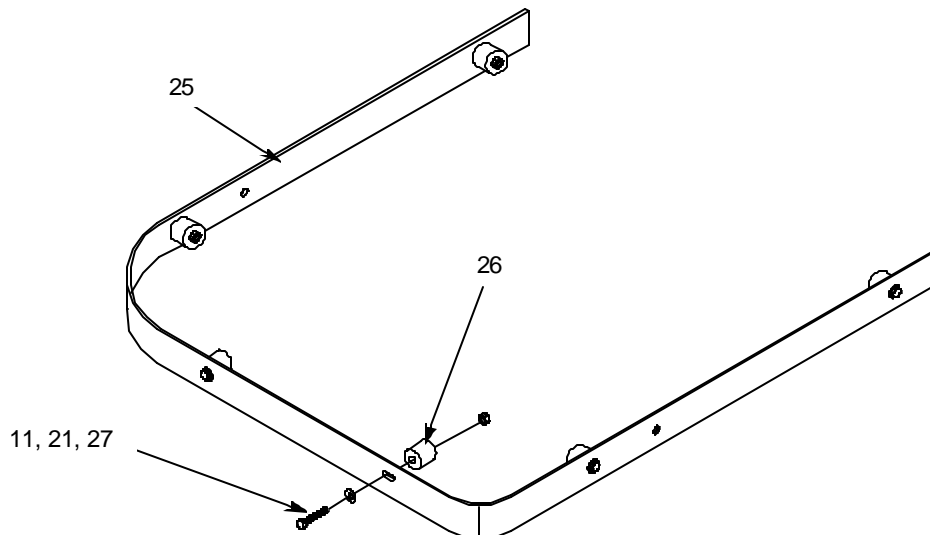

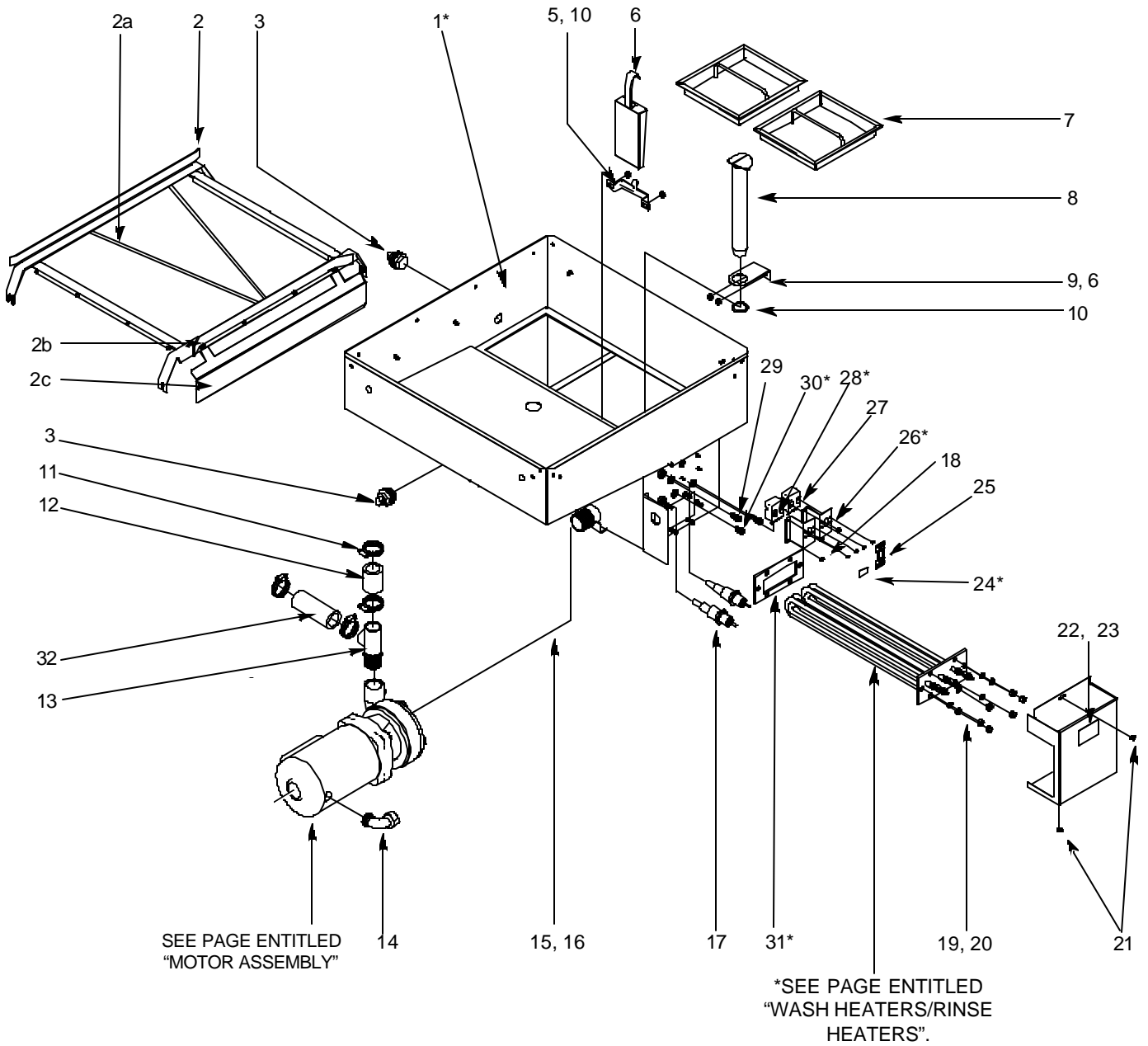

For the 200S, the steam coil assembly replaces the Heater and Gasket. To order the Complete Steam Coil Assembly, use part number 05700-002-08-62.

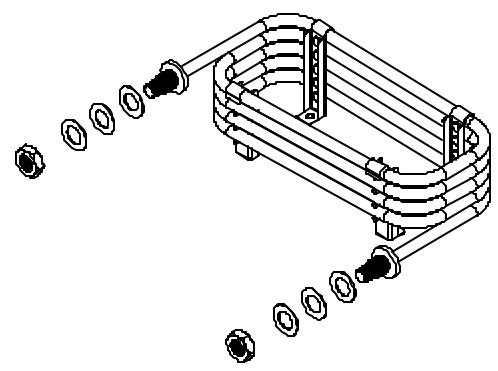

* Take note of quantities/use on 200S units.

TUB ASSEMBLY (CONTINUED)

ITEM	QTY	DESCRIPTION	Mfg. No.
1*	1	Tub Weldment (Not used on 200S)	05700-001-25-48
2	1	Rack Assembly	05700-001-22-16
2a	1	Support Rod	05700-000-94-59
2b	1	Rack Guide	05700-001-28-19
2c	1	Front Splash Guard	05700-001-29-58
3	2	Bulk Head Plug	04730-609-05-00
4	1	Suction Strainer Weldment	05700-001-22-23
5	1	Suction Strainer Bracket	05700-001-22-24
6	8	Locknut, 1/4"-20 with Nylon Insert	05310-374-02-00
7	2	Strainer Weldment	05700-001-22-25
8	1	Wash Overflow Weldment	05700-001-25-69
9	1	Overflow Support Bracket	05700-001-27-55
10	1	O-Ring	05330-400-03-08
11	4	Clamp, Hose 1 5/16" to 2 1/4"	04730-719-01-37
12	1	Hose, Bottom Manifold Pump, 1-3/4" Long x 1 1/2" I.D.	05700-001-22-92
13	1	Tee, Discharge (Machined)	05700-001-21-46
14	1	Connector, 1/2" 90°	05975-111-01-00
15	4	Nut, 3/8"-16 S/S Hex	05310-276-01-00
16	4	Lockwasher 3/8"	05311-276-01-00
17	2	Probe, High Water	06680-200-02-68
18	4	Locknut, 6-32 with Nylon Insert	05310-373-03-00
19	6	Lockwasher, 5/16", S/S, Split	05311-275-01-00
20	6	Nut, Hex, 5/16"-18, S/S	05310-275-01-00
21	4	Locknut, 10-24 with Nylon Insert	05310-373-01-00
22	1	Cover, Wash Heater	05700-001-22-40
23	1	Decal, Warning-Disconnect Power	09905-100-75-93
24*	1	Decal, High Limit (Not used on 200S)	09905-011-84-32
25	1	Decal, Thermostat Regulating	09905-011-84-31
26*	2	Thermostat Bracket (Only 1 used on 200S)	05700-011-81-64
27	1	Thermostat, Regulating	06401-140-00-32
28*	1	Thermostat, High Limit (Not used on 200S)	06401-002-81-30
29	1	Union, 1/4"	05700-001-16-52
30*	2	Fitting, 1/4" Imperial Brass (Only 1 used on 200S)	05310-924-02-05
31*	1	Wash Heater Gasket (Not used on 200S)	05330-200-01-70
32	1	Hose, Top Manifold Pump, 7" Long x 1 1/2" I.D.	05700-001-22-93

*1 Note: If you need a replacement Steam Tub Weldment, please have your serial number at hand and call technical support. Technical support is available from 8:00 a.m. to 5:00 p.m. (EST), Monday through Friday. Technical support is not available on holidays. Contact technical support toll free at 1-888-800-5672.

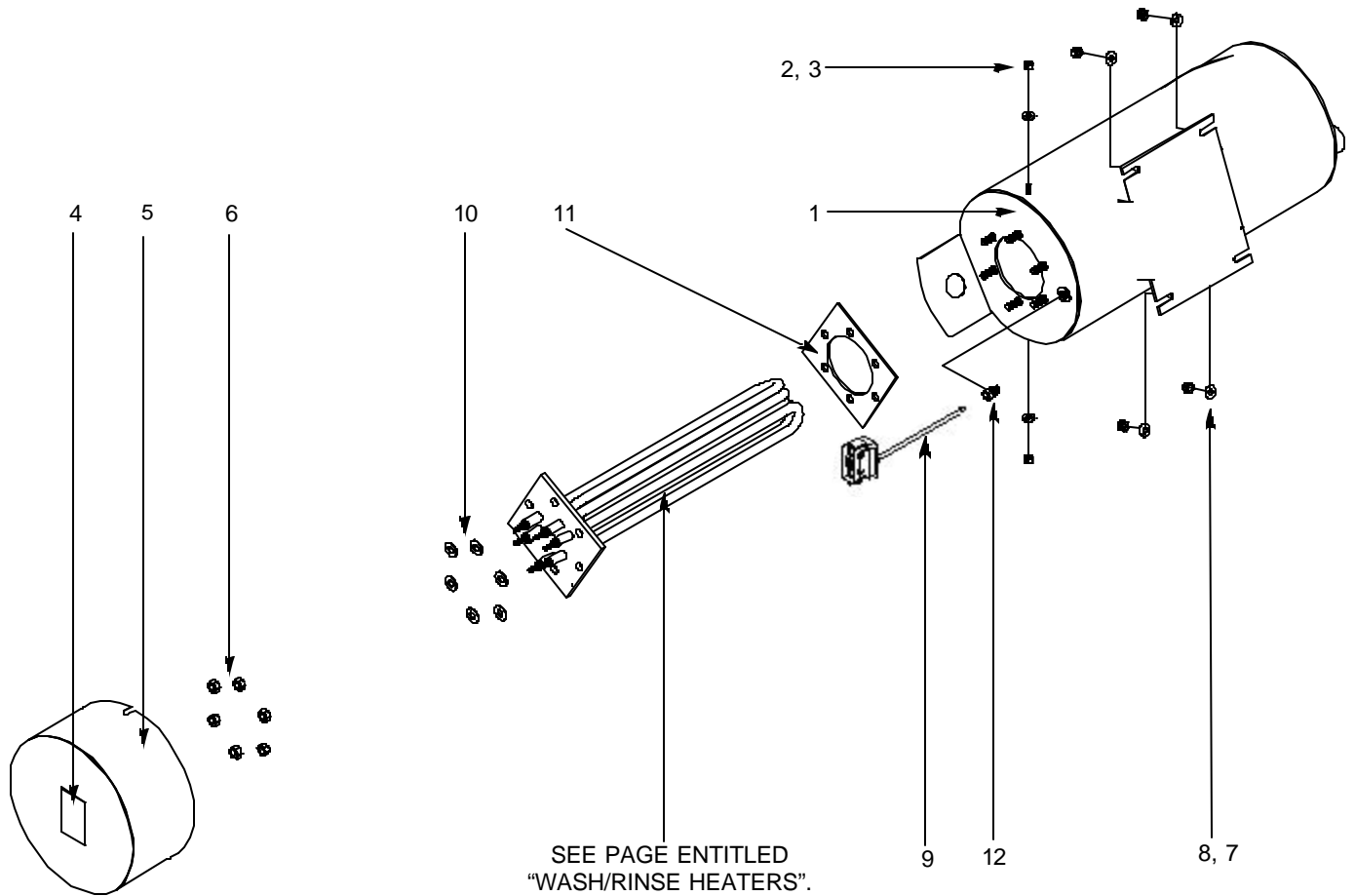

ITEM	QTY	DESCRIPTION	Mfg. No.
1	1	Booster Tank Weldment	05700-001-22-02
2	2	Locknut, 10-24 with Nylon Insert	05310-373-01-00
3	2	Washer, #10 S/S Flat	05311-173-01-00
4	1	Decal, Warning - Disconnect Power	09905-100-75-93
5	1	Booster Tank Cover Weldment	05700-001-29-30
6	6	Nut, Hex, 5/16"-18	05310-275-01-00
7	4	Washer, 1/4" ID, S/S, Flat	05311-174-01-00
8	4	Locknut, 1/4"-20 with Nylon Insert	05310-374-01-00
9	1	Thermostat, Rinse	05930-510-03-79
10	6	Washer, 5/16" I.D.	05311-175-01-00
11	1	Gasket, Rinse Heater	05330-200-02-70
12	1	Fitting, 1/4" Imperial Brass	05310-924-02-05

WASH HEATERS/RINSE HEATERS

The 200 models covered in this manual come supplied with various heaters, depending on the characteristics of the machine. To ensure that you order the correct heater for the model you are servicing, please refer to the following table:

<u>Model KW)</u>	<u>Volts</u>	<u>Hz</u>	<u>Phase</u>	<u>Wash Heater</u>	<u>40°F Rise Rinse Heater (12 KW)</u>	<u>70°F Rise Rinse Heater (14</u>
200B	208	60	1	04540-100-02-15	04540-121-47-40	04540-121-63-38
200B	230	60	1	04540-100-02-15	04540-121-47-40	04540-121-63-38
200B	208	60	3	04540-100-02-15	04540-121-47-40	04540-121-63-38
200B	230	60	3	04540-100-02-15	04540-121-47-40	04540-121-63-38
200B	460	60	3	04540-100-03-15	04540-100-01-15	04540-121-63-39
200	208	60	1	04540-100-02-15		
200	230	60	1	04540-100-02-15		
200	208	60	3	04540-100-02-15		
200	230	60	3	04540-100-02-15		
200	460	60	3	04540-100-03-15		
200LT	208	60	1	04540-100-02-15		
200LT	230	60	1	04540-100-02-15		
200LT	208	60	3	04540-100-02-15		
200LT	230	60	3	04540-100-02-15		
200LT	460	60	3	04540-100-03-15		

Rinse Heater Diagrams

Single (1PH) Phase Heater Busing

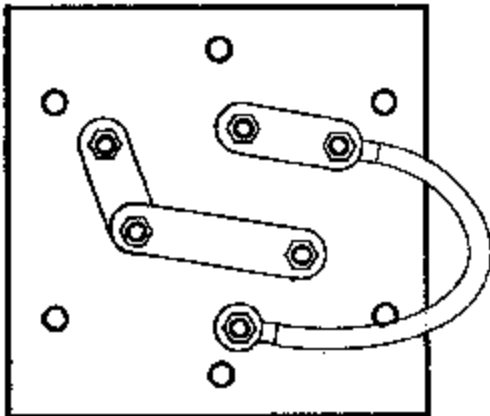

Three (3PH) Phase Heater Busing

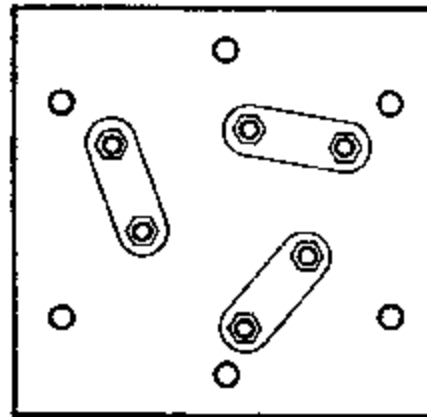

Wash Heater Diagrams

Single (1PH) Phase Heater Busing

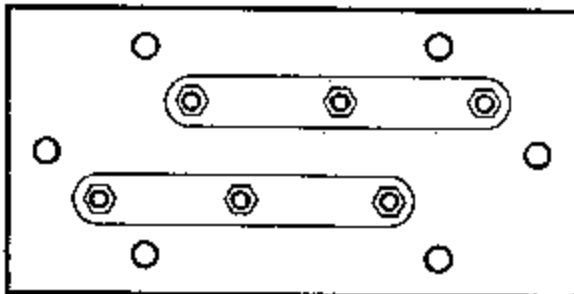

Three (3PH) Phase Heater Busing

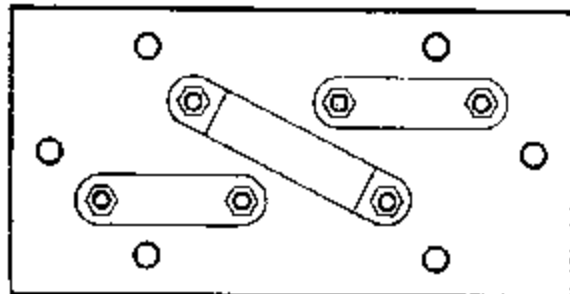

SECTION 6: PARTS SECTION

MOTOR ASSEMBLY

The 200 models covered in this manual come supplied with various wash motor assemblies (a wash motor assembly includes the wash motor and the pump end), depending on the characteristics of the machine. To ensure that you order the correct wash motor assembly for the model you are servicing, please refer to the following table:

<u>Model</u>	<u>Volts</u>	<u>Hz</u>	<u>Phase</u>	<u>Wash Motor Assembly</u>
200/200B/200LT/200S	208	60	1	06105-102-05-94
200/200B/200LT/200S	230	60	1	06105-102-05-94
200/200B/200LT/200S	208	60	3	06105-102-04-94
200/200B/200LT/200S	230	60	3	06105-102-04-94
200/200B/200LT/200S	460	60	3	06105-102-04-94

Important note: When servicing a wash motor, it is important to refer to the wiring schematic found on the motor, to ensure that the motor is wired correctly. Different manufacturers of motors may not use the same wire color codes and therefore, your new motor, which may have been built by someone different than who built your original motor, may not connect using the same wires. Always refer to the wiring diagrams on the motor you are installing. If the motor you are installing has had the schematic removed, contact Jackson MSC immediately for technical support.

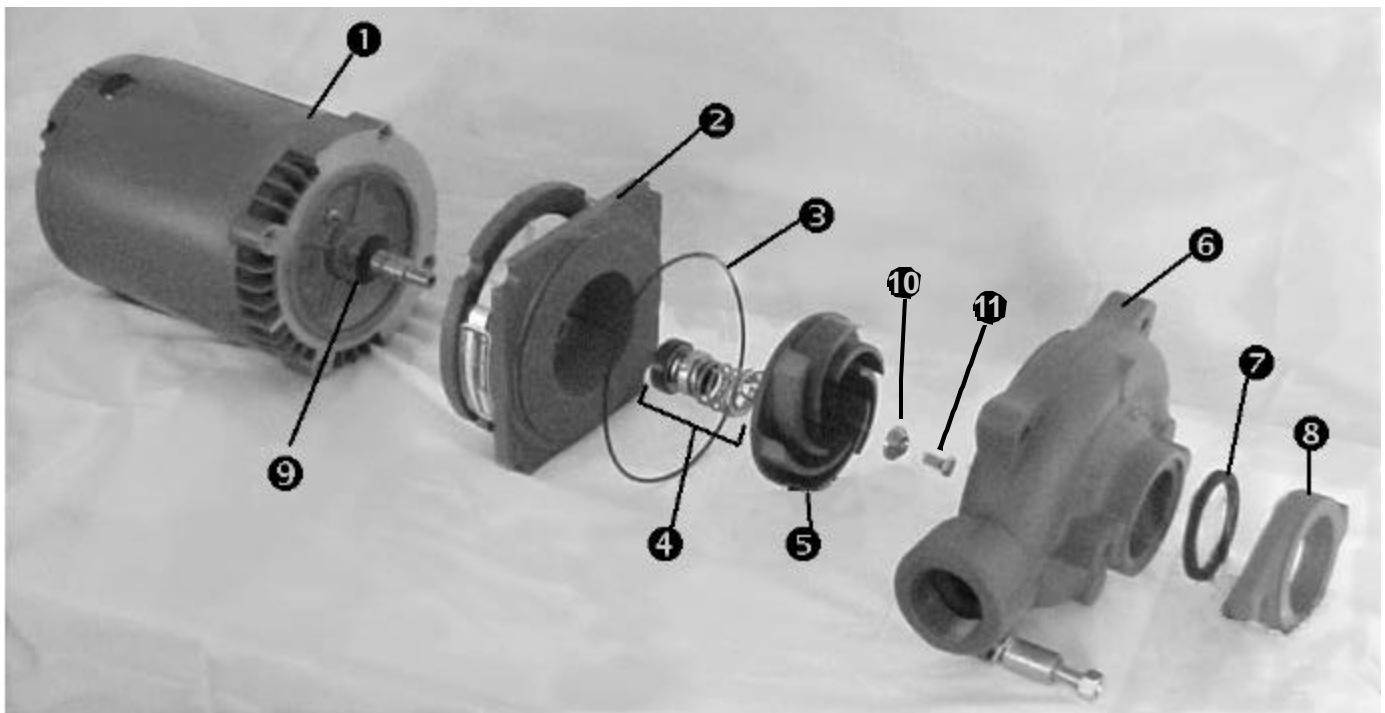

ITEM	DESCRIPTION	Mfg. No.
1	Motor, 208/230/460V, 1 HP, 1 Phase	06105-102-08-94
1	Motor, 208/230/460V, 1 HP, 3 Phase	06105-102-01-94
2	Adapter Plate	04730-801-00-00
3	O-Ring, Adapter Plate	05330-400-18-00
4	Mechanical Seal	05330-300-07-27
5	Impeller	04320-300-44-00
6	Pump Casing	04320-300-45-00
7	"Square Ring" Seal	05330-500-23-00
8	Flange, Suction Pipe	04320-300-43-00
9	Slinger Washer	N/A
10	Washer (3 phase only)	N/A
11	Screw, 1/4"-28 x 1/2" (3 pahse only)	N/A

FRAME ASSEMBLY

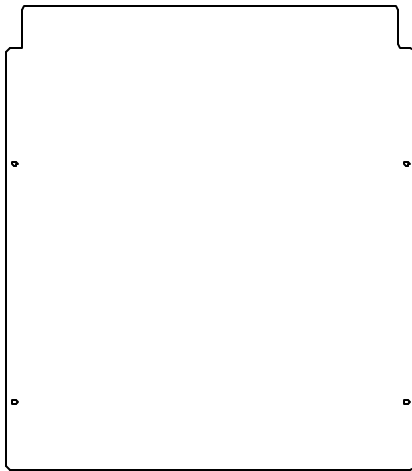

Front Panel Assembly
with Mounting Hardware
05700-001-25-80

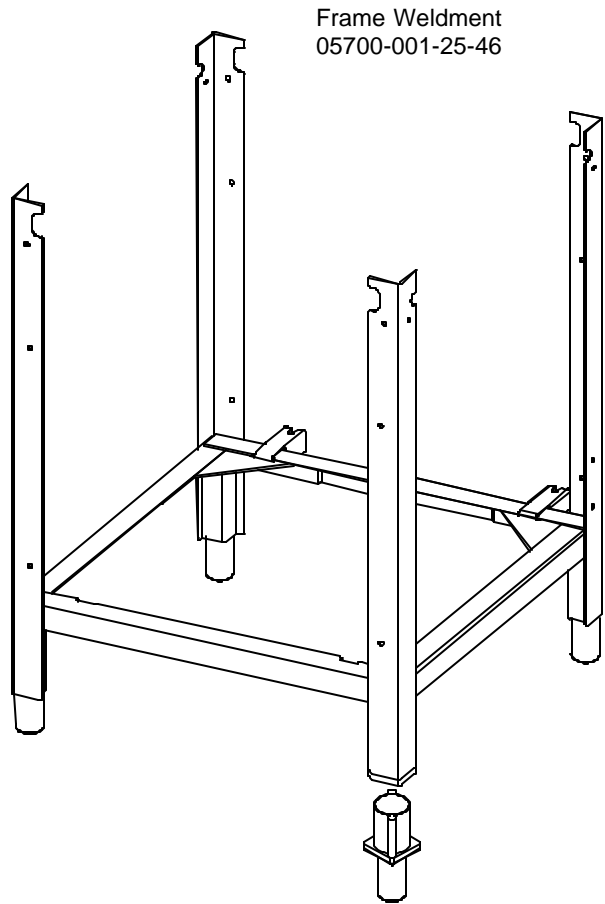

Frame Weldment
05700-001-25-46

Bullet Foot
05340-108-02-06

Bullet Foot (Option)
05340-002-01-15

200B INCOMING FILL PLUMBING

200B OUTLET PLUMBING

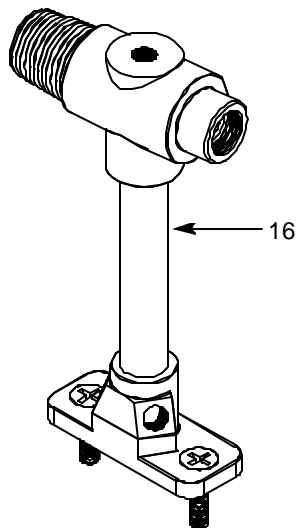
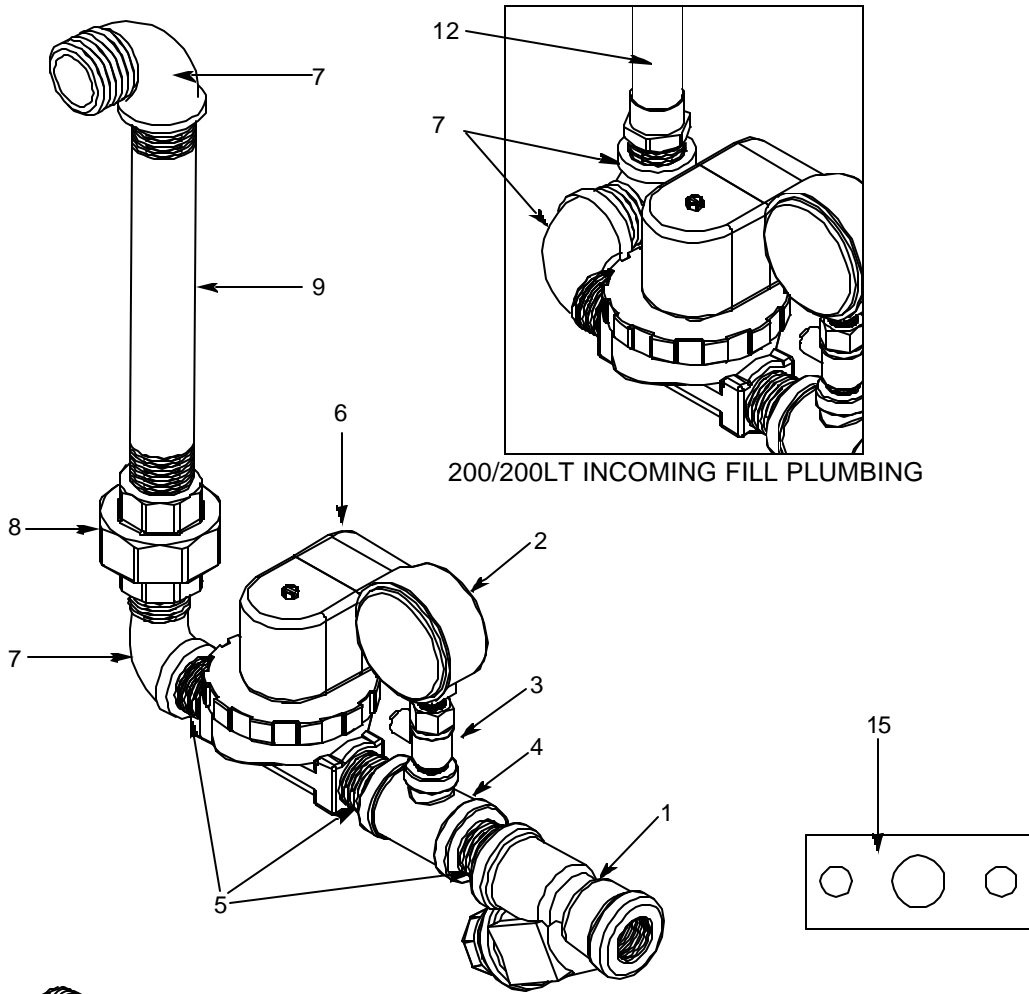

When servicing plumbing components, take care not to damage the threads of each individual item. Damaged threads can cause leaks and loss of pressure, which could adversely effect the performance of the Tempstar dishmachine. It is strongly recommended that teflon thread tape, used in conservative amounts, be applied to threads when joining components together. It is not advised to use thread sealing compounds, sometimes referred to as "pipe dope". Compounds can be ejected from the threads during the tightening process and become lodged in key components, thereby rendering them useless. Some of the components include the solenoid valve and the pressure gauge isolation ball valve.

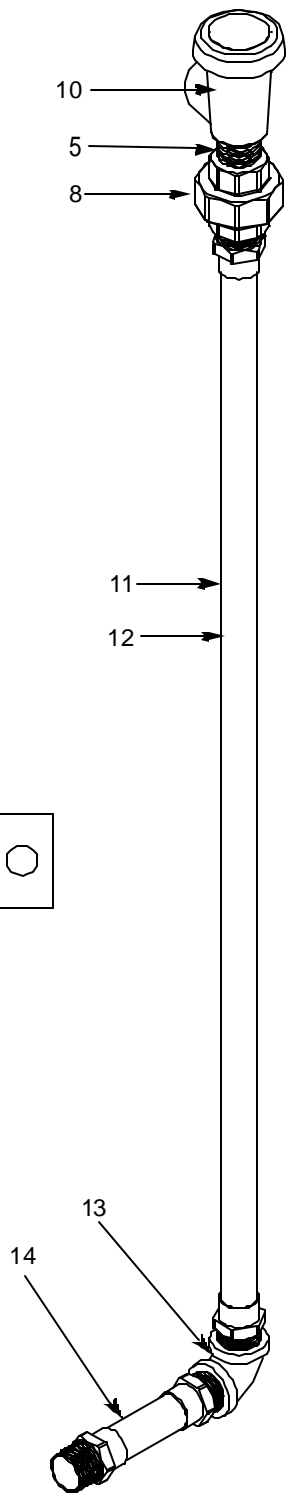

INCOMING FILL PLUMBING/OUTLET PLUMBING (CONTINUED)

ITEM	QTY	DESCRIPTION	Mfg. No.
1	1	Y Strainer 3/4" NPT	04730-717-02-06
2	1	Gauge, Pressure, 0-100 PSI	06685-111-88-34
3	1	Valve, Ball, 1/4" NPT	04810-011-72-67
4	1	Tee, Brass, 3/4" NPT x 3/4" NPT x 1/4" NPT	04730-211-04-00
5	4	Nipple, Close, 3/4" NPT	04730-207-34-00
6	1	Valve, Solenoid, 3/4" NPT, 24V	04810-100-01-40
7	2	Elbow, 3/4" NPT, Brass, 90° Street (Note configuration for 200/200LT)	04730-206-04-34
8	2	Union Assembly (1 Only for 200/200LT)	05700-002-63-79
8a	1	Union, 3/4" NPT, Brass	04730-212-05-00
8b	1	O-Ring	05330-400-05-00
9	1	Nipple, 3/4" x 6" Brass (200B Only)	05700-001-26-74
10	1	Vacuum Breaker, 3/4" NPT	04820-002-53-77
11	1	Nipple Assembly (200B)	05700-001-26-73
11a	2	Adapter, 3/4" Male	04730-401-11-01
11b	1	Tube, Copper 3/4" x 29 3/8"	05700-011-82-29
12	1	Nipple Assembly (200/200LT)	05700-001-26-14
12a	2	Adapter, 3/4" Male	04730-401-11-01
12b	1	Tube, Copper 3/4" x 46 3/8"	05700-011-65-25
13	1	Elbow, 3/4" NPT, 90° Brass (200B Only)	04730-206-13-00
14	1	Nipple Assembly (200B Only)	05700-001-26-72
14a	2	Adapter, 3/4" Male	04730-401-11-01
14b	1	Tube, Copper 3/4" x 2 7/8"	05700-011-76-76
15	2	Rinse Injector Gasket	05330-500-19-00
16	1	Rinse Injector Weldment	05700-001-25-78
16a	3	Plug, 1/8" NPT, Brass	04730-209-07-37
16b	1	Union, 1/4" Brass (For Thermostat Probe)	05700-001-16-52

WATER PRESSURE REGULATOR KIT (WPRK) OPTION PLUMBING

To order this complete assembly use part number 05700-001-96-41.

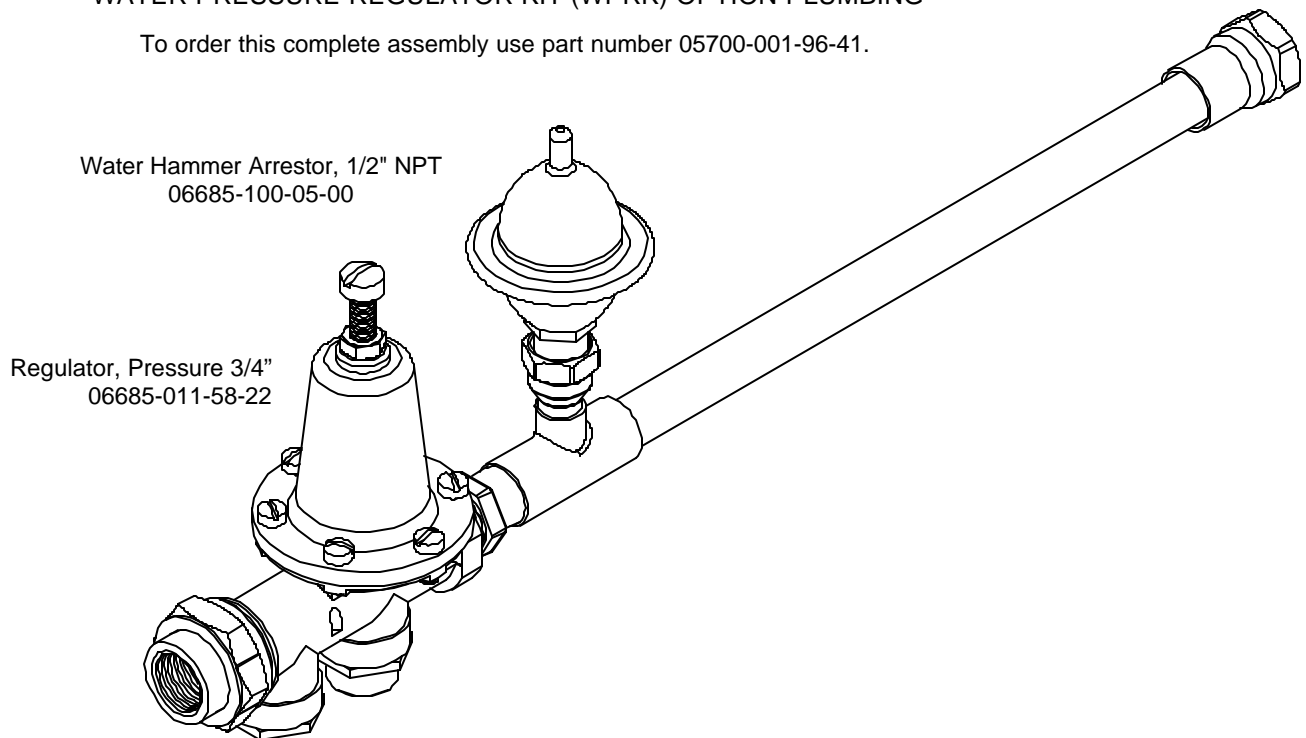

SECTION 6: PARTS SECTION

3/4" SOLENOID VALVE & 3/4" NPT VACUUM BREAKER REPAIR PARTS KITS

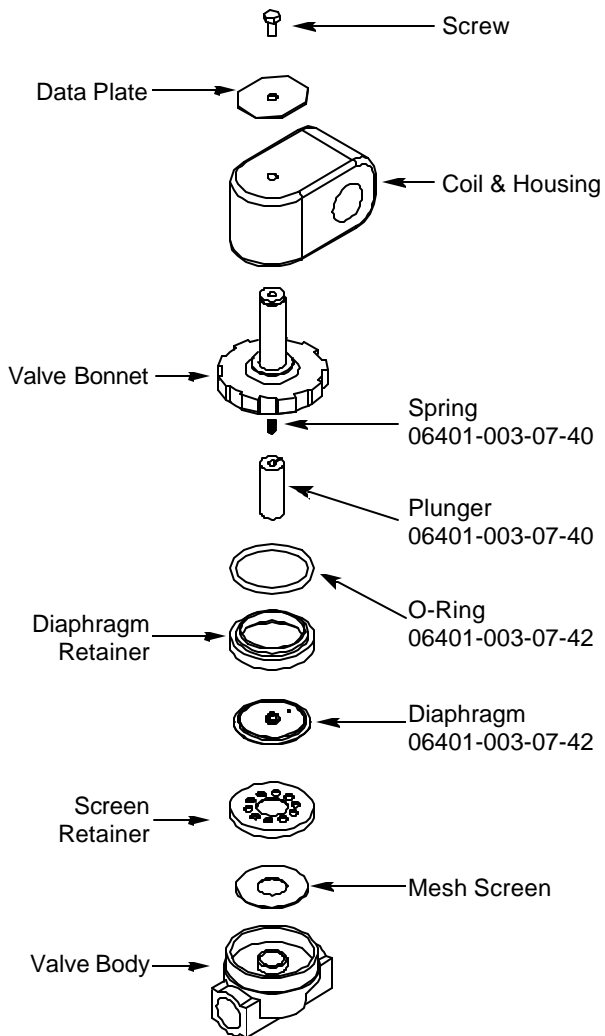

Complete 24 Volt Solenoid Valve Assembly
04820-100-01-40

Coil & Housing only
04810-100-06-18

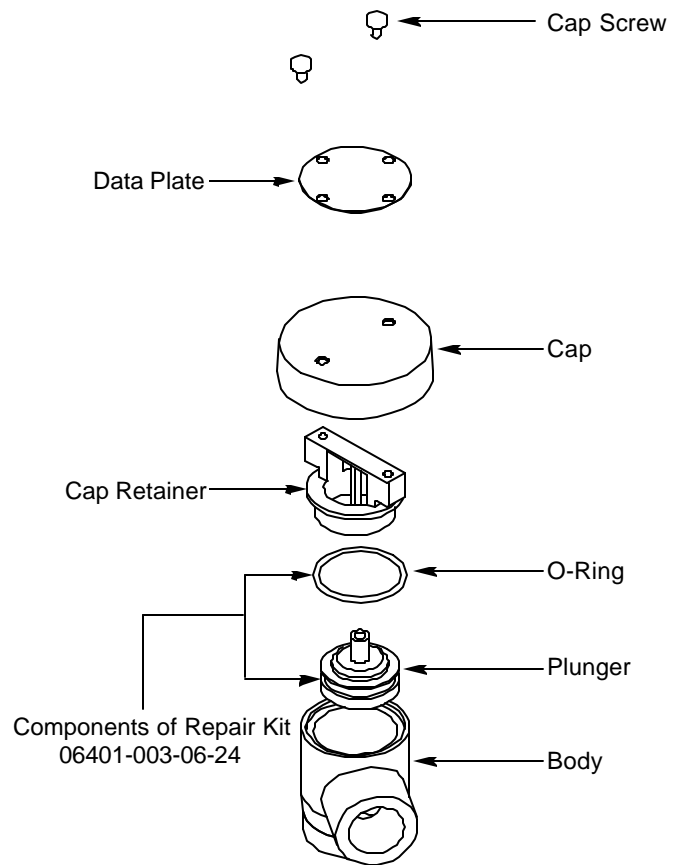

Complete Vacuum Breaker Assembly
04820-002-53-77

COIL ASSEMBLY (200S)

Complete Steam Coil Assembly
05700-002-08-62

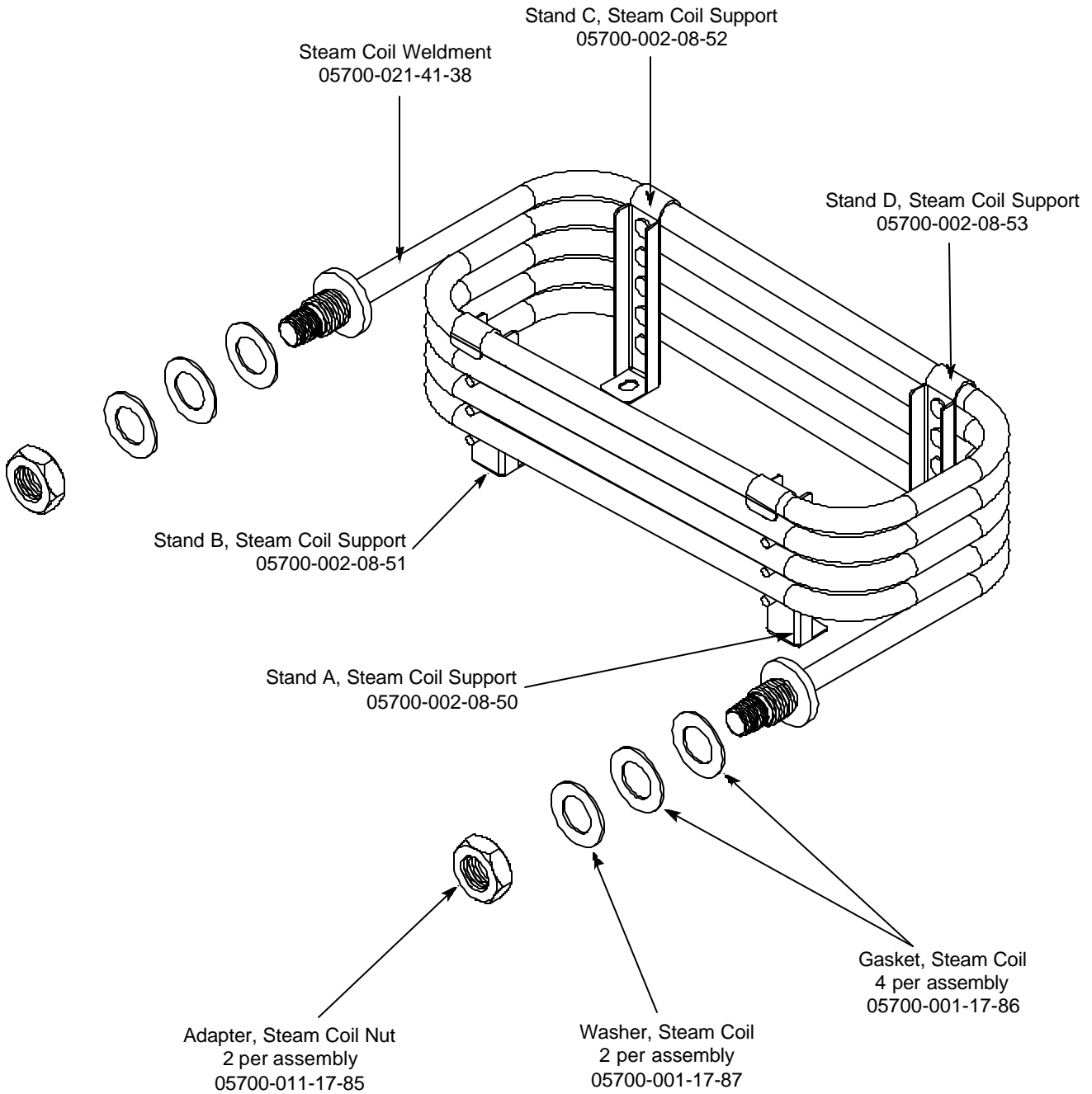

SECTION 6: PARTS SECTION

INCOMING STEAM PLUMBING ASSEMBLY (200S)

To order this complete assembly, use part number 05700-041-42-73.

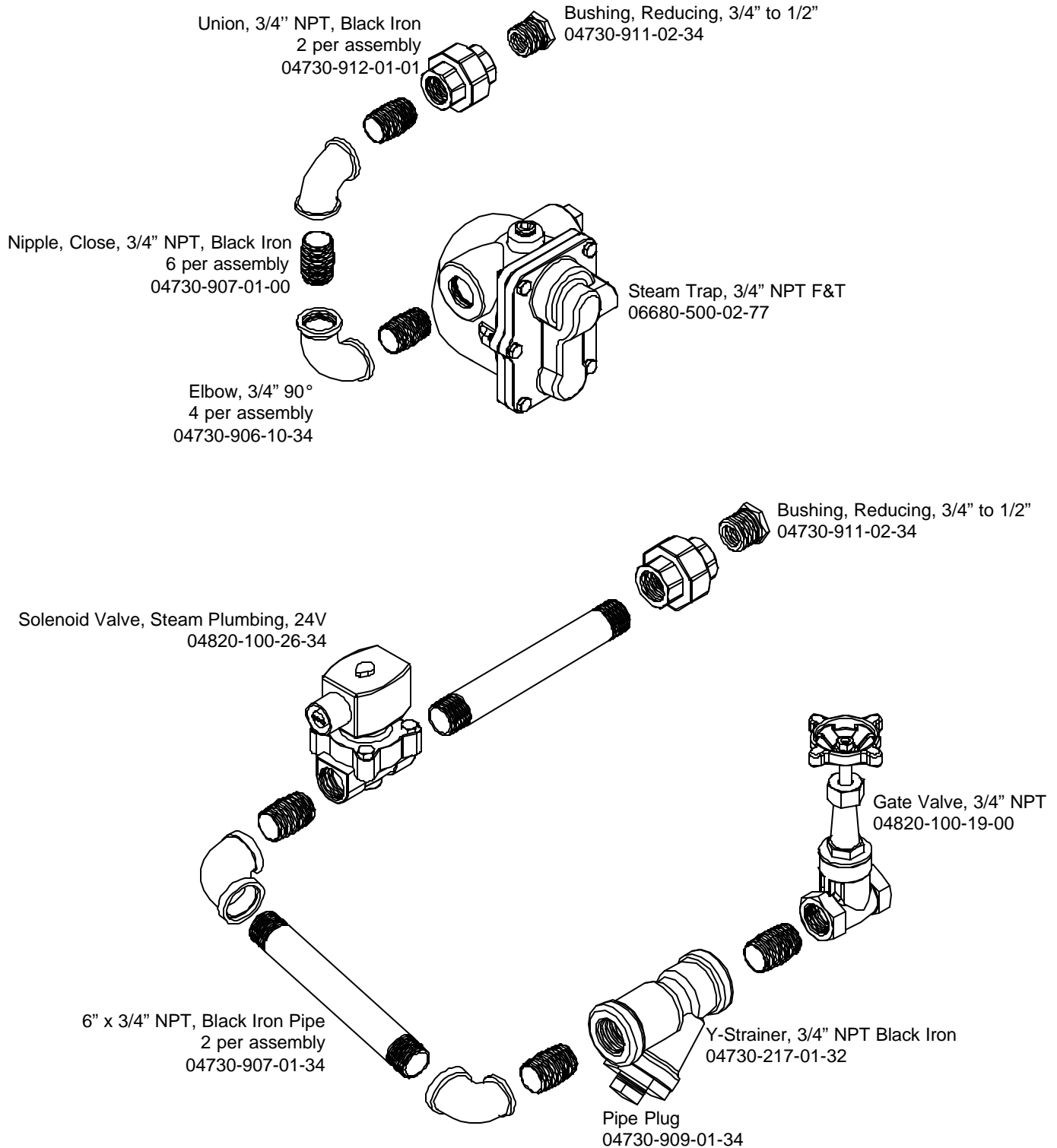

WASH & RINSE ARM/MANIFOLD ASSEMBLIES

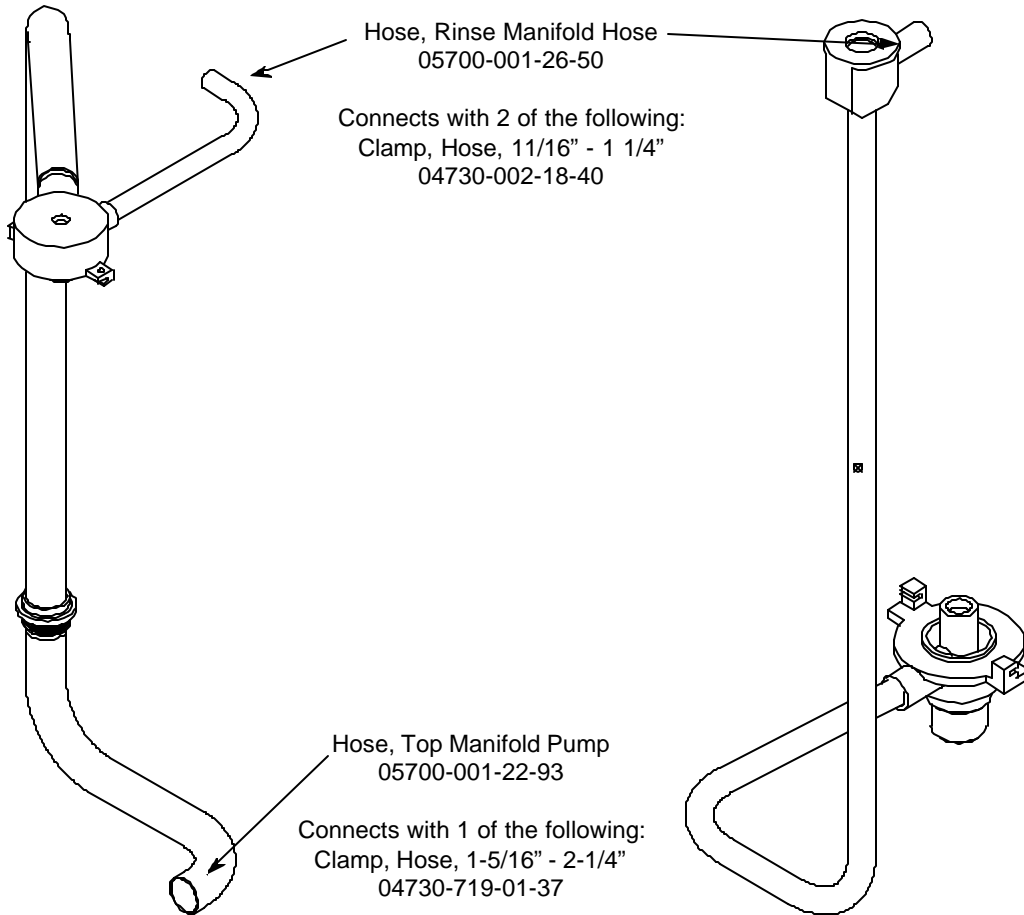

Top Wash & Rinse Manifold Assembly
05700-001-25-52

Bottom Wash & Rinse Manifold Assembly
05700-001-25-53

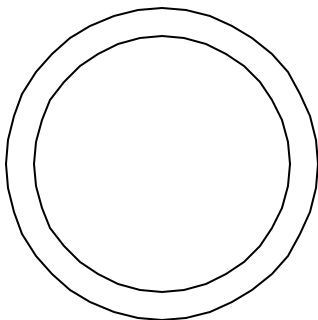

Manifold Gasket
2 per
05330-500-18-00

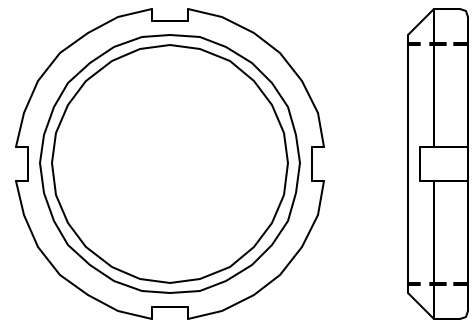

Manifold Spanner Nut
05700-001-22-56

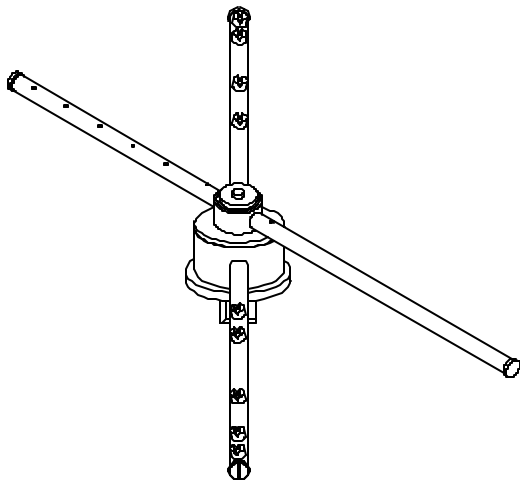

Wash & Rinse Spindle Assembly
05700-031-42-01

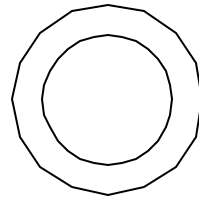

O-Ring, Rinse Manifold
05330-400-16-00



Plunger, Ball
1 per manifold assembly
05315-707-02-00

EXPLODED VIEW OF WASH & RINSE SPINDLE ASSEMBLY

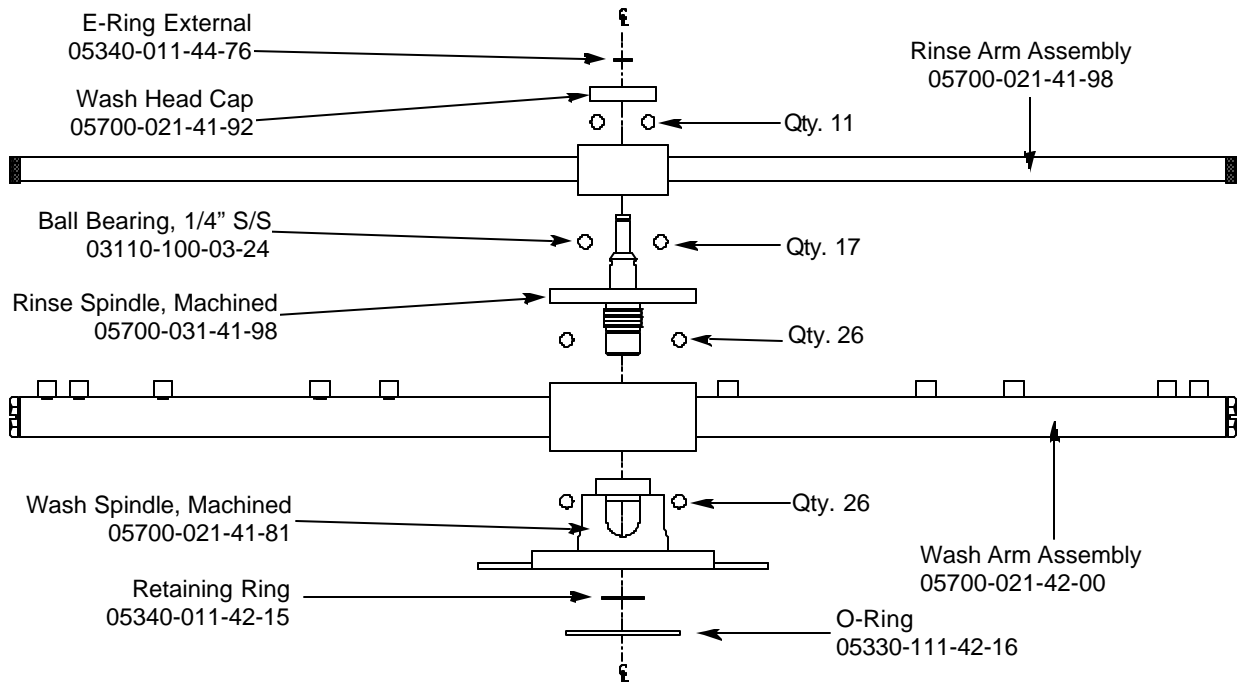

SAFETY DOOR INTERLOCK (SDI) OPTION

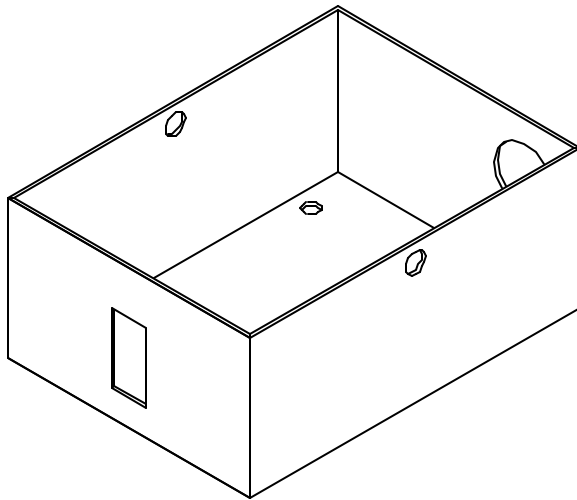

Safety Door Interlock Box Bottom
05700-001-21-26

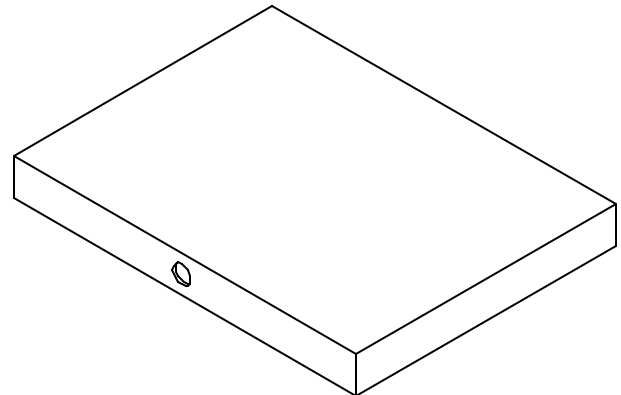

Safety Door Interlock Box Cover
05700-001-21-27

Other Safety Door Interlock (SDI) components (not shown):

- Pipe Clamp (found on the side of the machine) 05700-000-35-05
- Solenoid, Electrical Interlock Option 04810-100-61-33
- Relay 05945-109-03-09

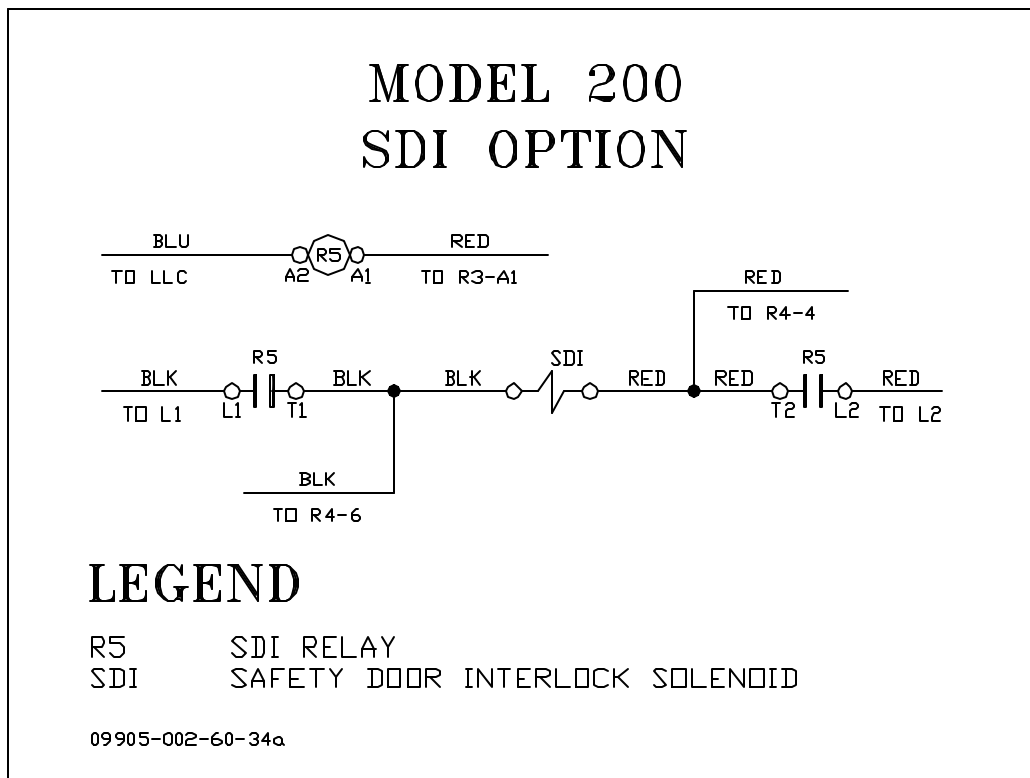

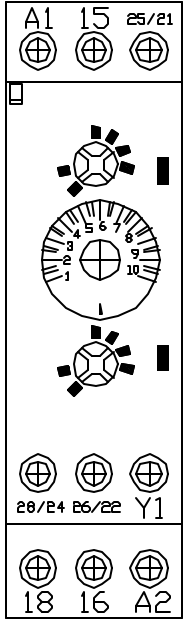

Delay Timer
05945-011-65-44

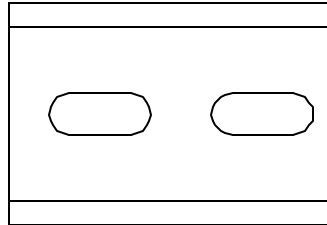

2" Din Rail
05700-002-36-09

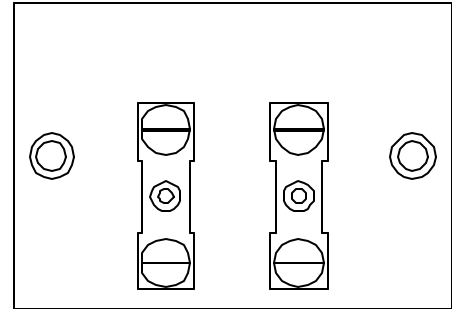

Terminal Board
05940-011-84-41

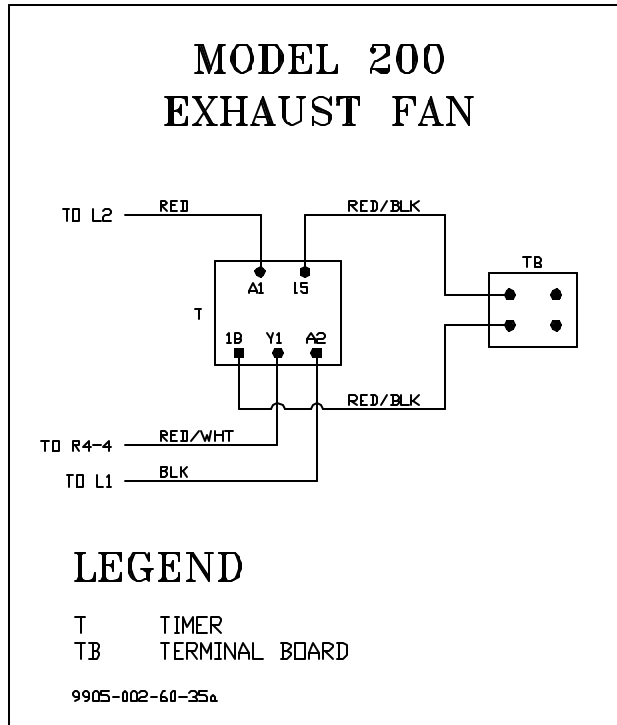

FALSE PANEL INSTALLATION

Front False Panel
05700-001-29-39

Front False Panel Kit with Hardware
05700-021-30-39

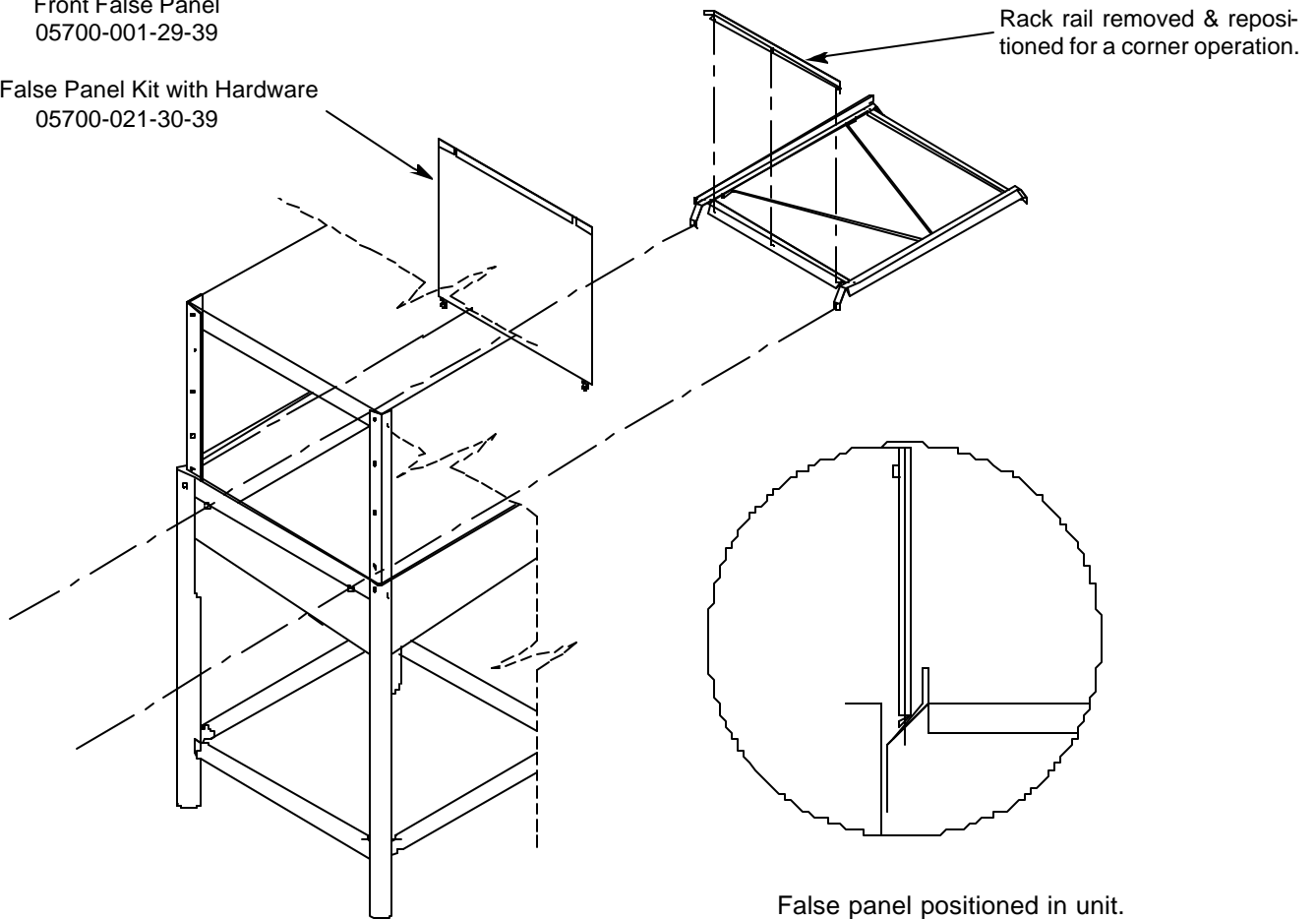

False panel positioned in unit.

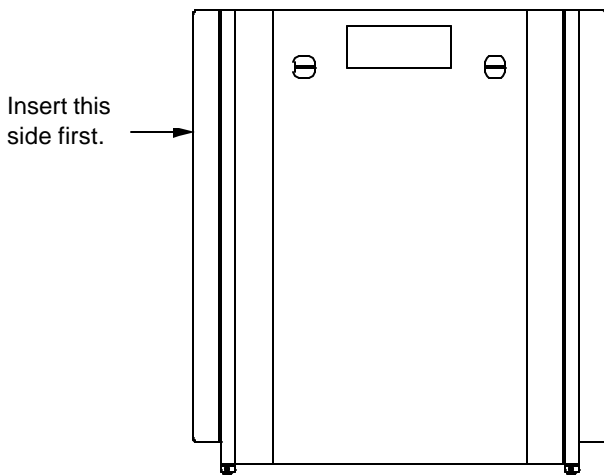

Bottom of side panel.

1. Loosen the rack assembly from the unit.
2. False panel will mount to the rack; inside the dishmachine.
3. Position panel in unit on side to be closed.
4. Hold panel against side of dishmachine and push up.
5. Panel will clip inside the unit under the edge of the hood.
6. Holes in false panel will line up with rack assembly holes.
7. Re-install screws for rack assembly which will secure false panel to unit.
8. Re-assemble the rack track in an "L" shape for a corner operation.

SECTION 7: ELECTRICAL SCHEMATICS

SECTION 7: ELECTRICAL SCHEMATICS

200/200B/200LT 208-230-460V, 50/60 HZ, SINGLE & THREE PHASE

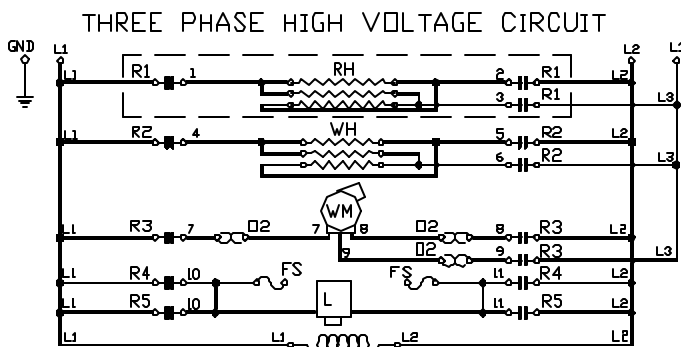
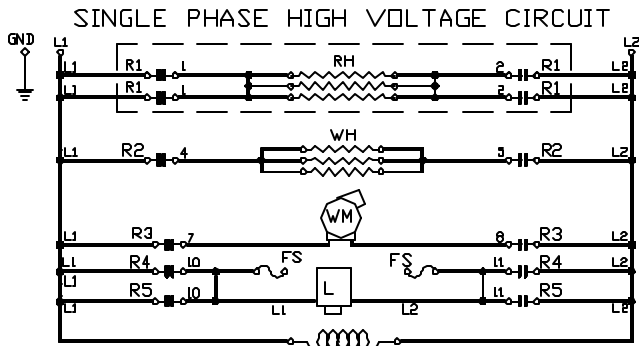

LOW VOLTAGE CONTROL CIRCUIT

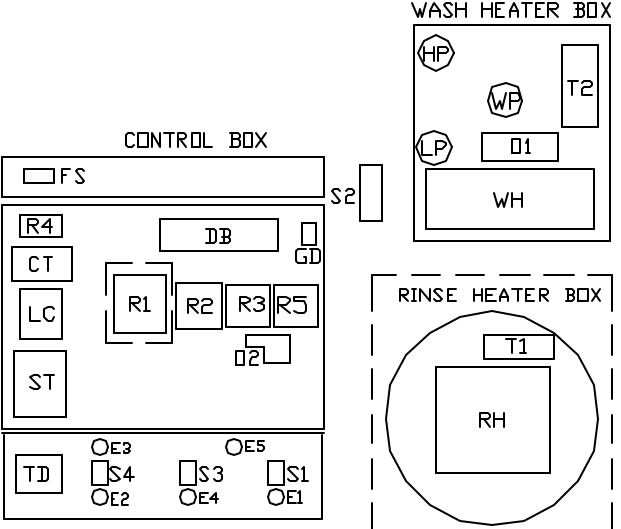
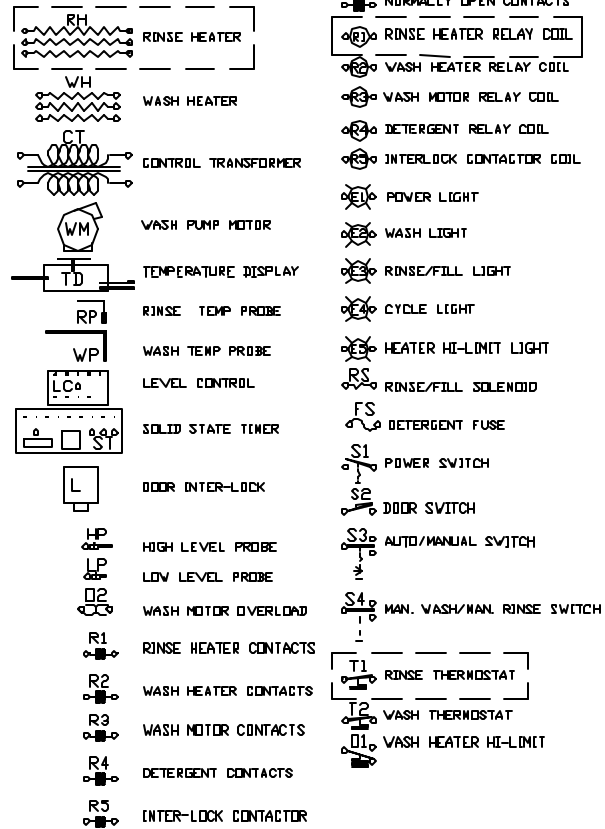
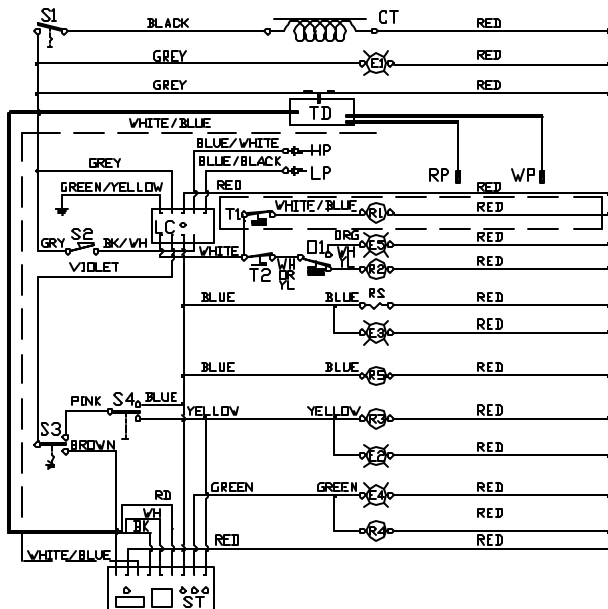

NOTES: COMPONENTS WITH DOTTED LINES AROUND THEM ARE ADDED FOR BOOSTER OPTION

Dashed White/Blue wire is added for Sani-sure Option. Sani-sure can only be installed on machines with booster option.

9905-105-01-12

SECTION 7: ELECTRICAL SCHEMATICS

200S 208-230-460V, 50/60 HZ, SINGLE & THREE PHASE

SINGLE PHASE HIGH VOLTAGE CIRCUIT

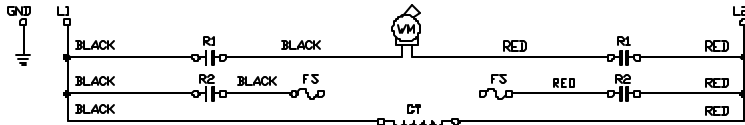

THREE PHASE HIGH VOLTAGE CIRCUIT

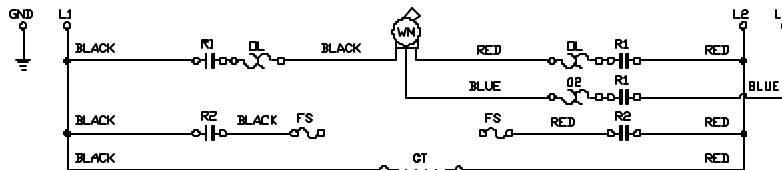

LOW VOLTAGE CONTROL CIRCUIT

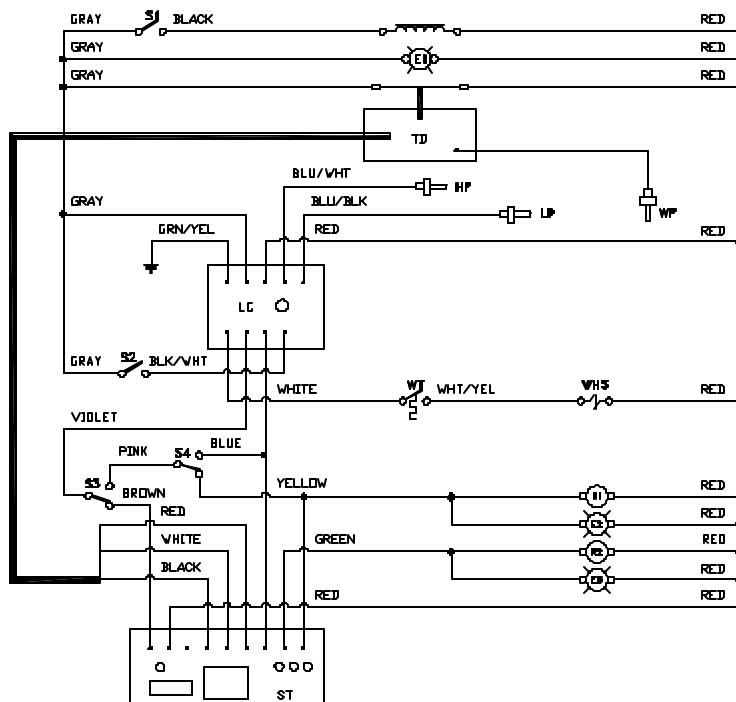

LEGEND

- L1 L2 L3 POWER DISTRIBUTION BLOCK
- GND GROUND
- VM WASH MOTOR
- R1 DETERGENT RELAY
- R2 DETERGENT RELAY
- FS DETERGENT FUSE
- CT CONTROL TRANSFORMER
- OL WASH MOTOR OVERLOAD
- S1 POWER SWITCH
- E1 POWER LIGHT
- TD TEMPERATURE DISPLAY
- HP HIGH LEVEL PROBE
- LP LOW LEVEL PROBE
- VP WASH TEMPERATURE PROBE
- LC LEVEL CONTROL
- S2 DOOR SWITCH
- WT WASH THERMOSTAT
- S3 AUTO/MANUAL SWITCH
- S4 CONTROL CIRCUIT TRANSFORMER FUSE
- VHS WASH HEAT SOLENOID
- E2 WASH LIGHT
- E3 CYCLE LIGHT
- ST SOLID STATE TIMER

WASH HEATER BOX

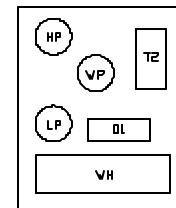

CONTROL BOX

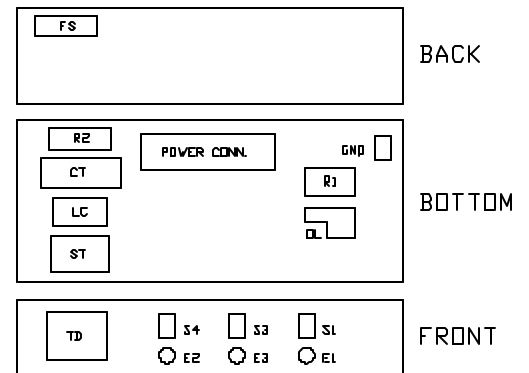

9905-031-94-17

