

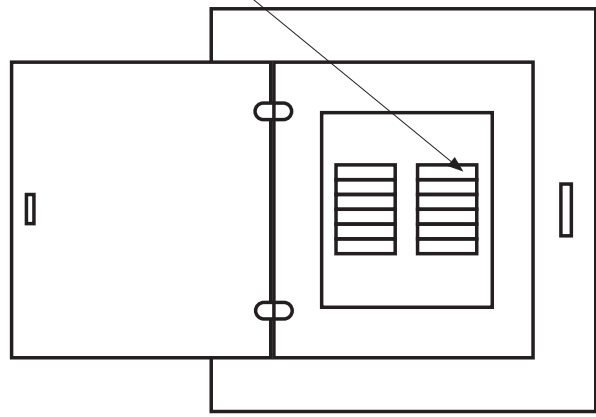

10  

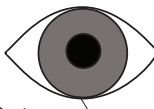



13  

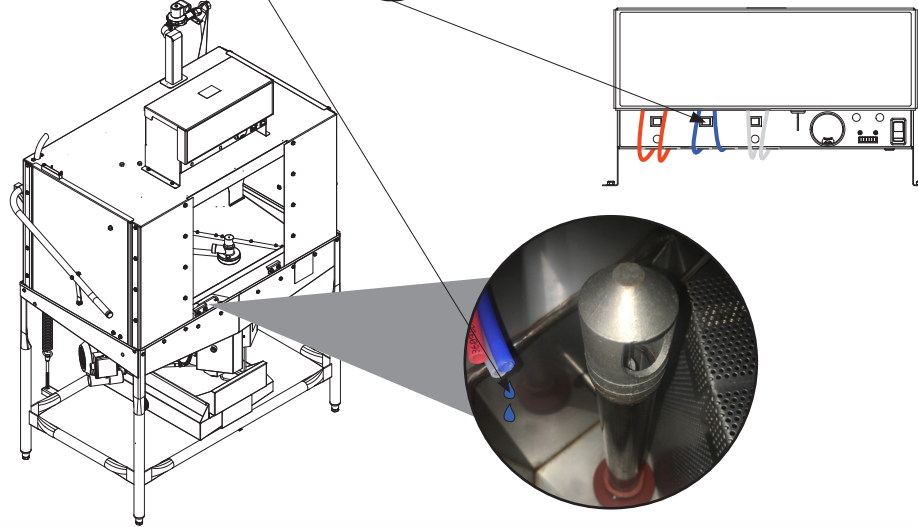

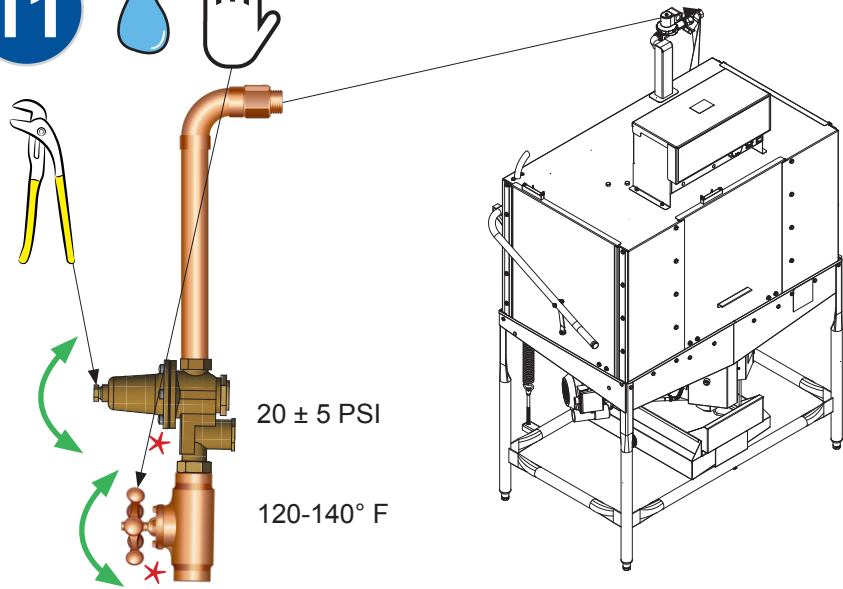

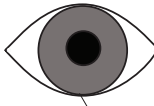
11  

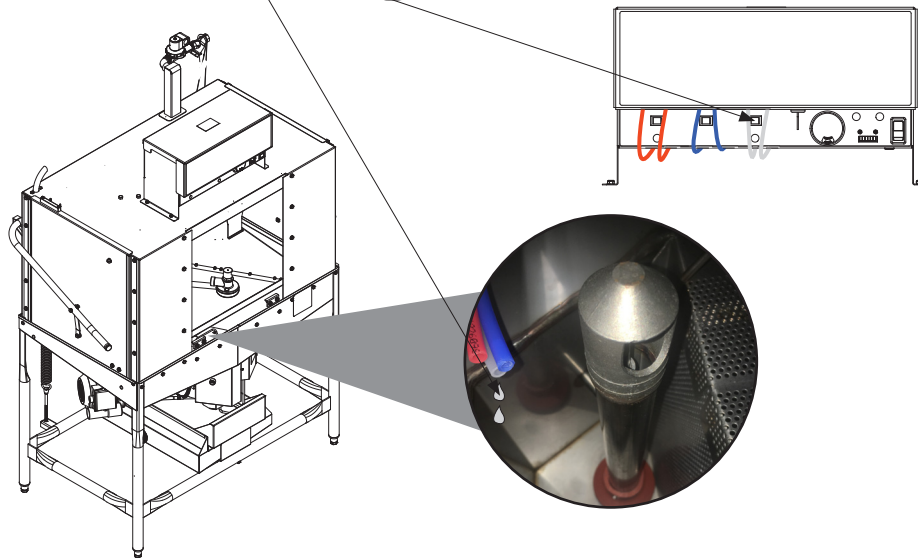

14  

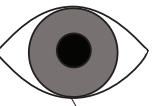

12  

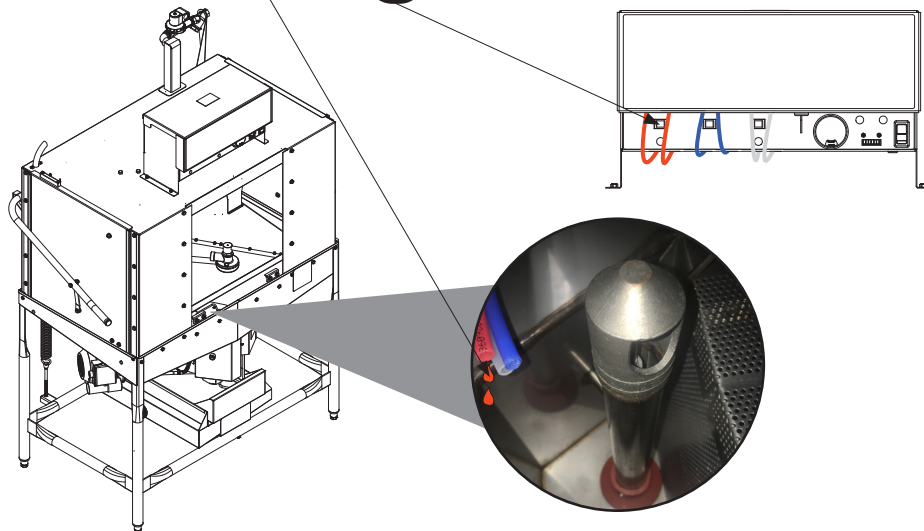

For Technical Support, call the number below.

For the full Conserver® XL2 Manual, scan the QR Code below or go to our website.



1.888.800.5672
www.jacksonwvs.com

Jackson®

Warewashing Systems

INSTALLATION
QUICK GUIDE

CONSERVER® XL2



= risk of electric shock
riesgo de electrocución
risque de décharge électrique



= caustic chemicals
químicos cáusticos
produits chimiques caustiques



= ground wire
cable a tierra
fil de terre



= verify
verificar
vérifier



= use fingers/hands
utilizar los dedos/manos
utilisez vos doigts/mains



= use eyes
utiliza tus ojos
utilisez vos yeux



= reference data plate
mire la placa de datos
regarder la plaque signalétique



= water
agua
eau



= not supplied
no se suministra
non fourni



= level
nivel
niveau

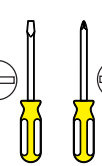
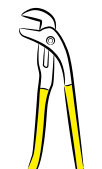

1 

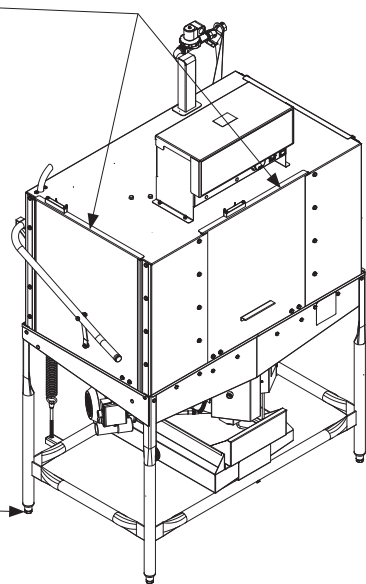
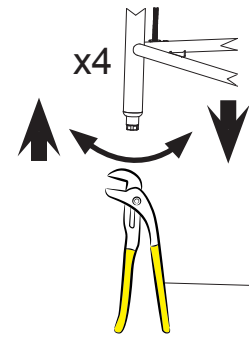

4 

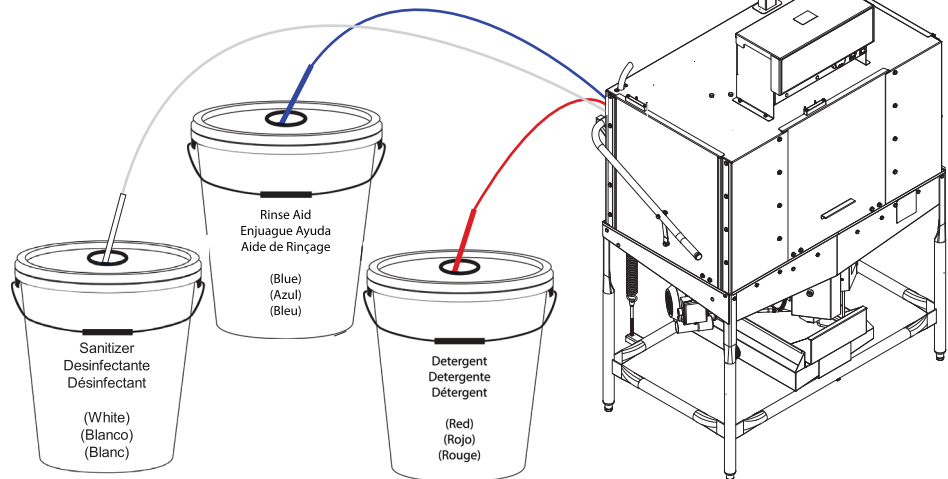

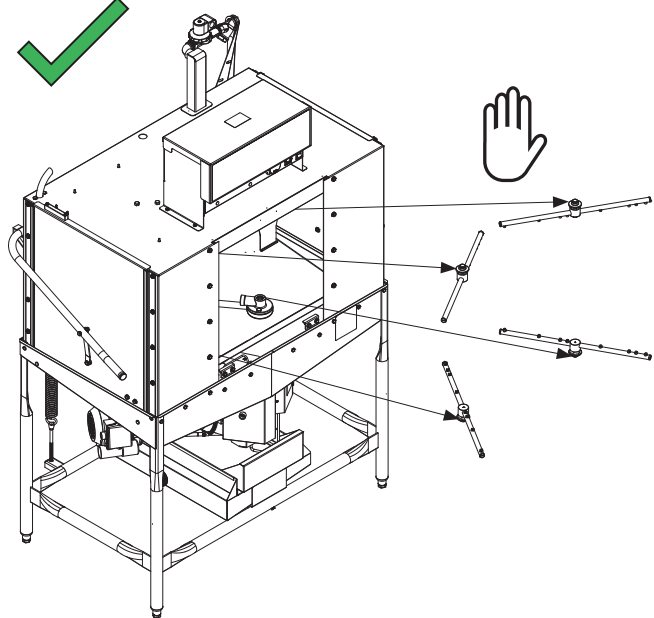

7  



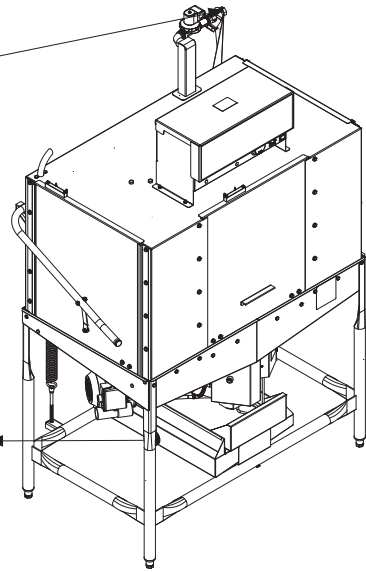
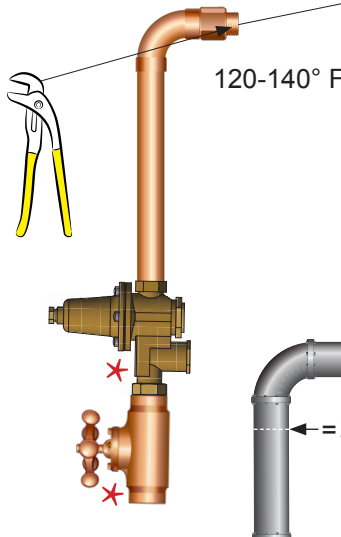

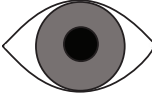
2 

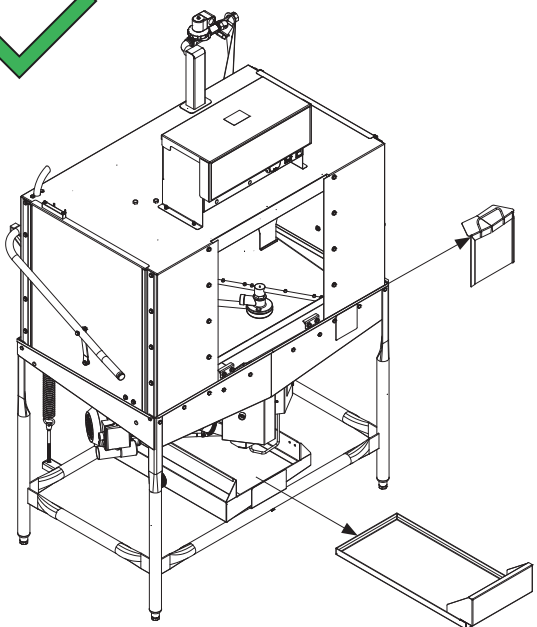

5  



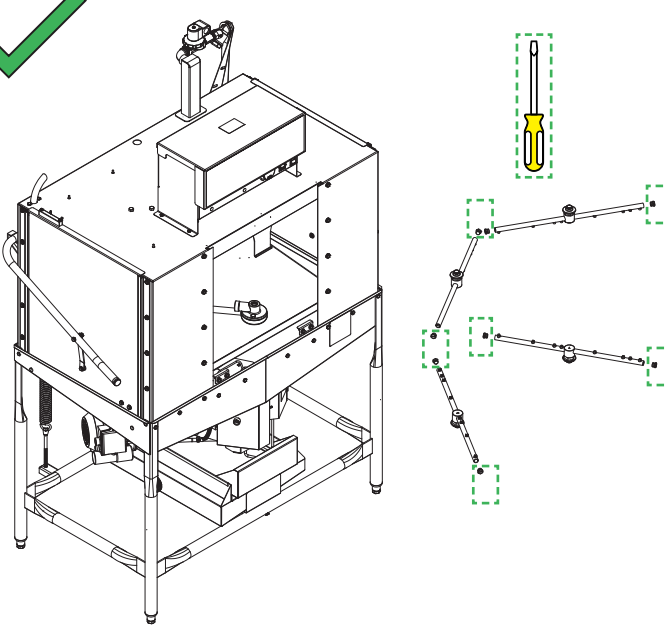

8  

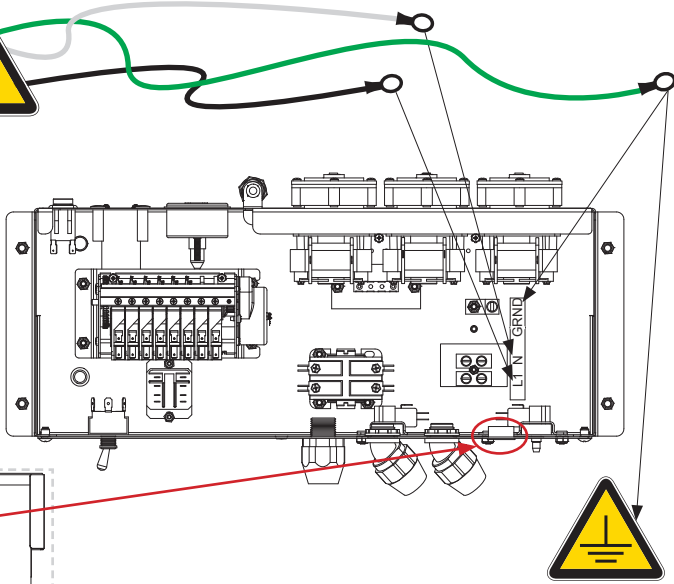
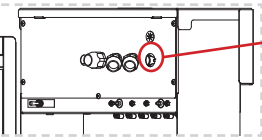
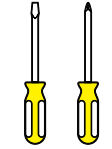

3 



6  

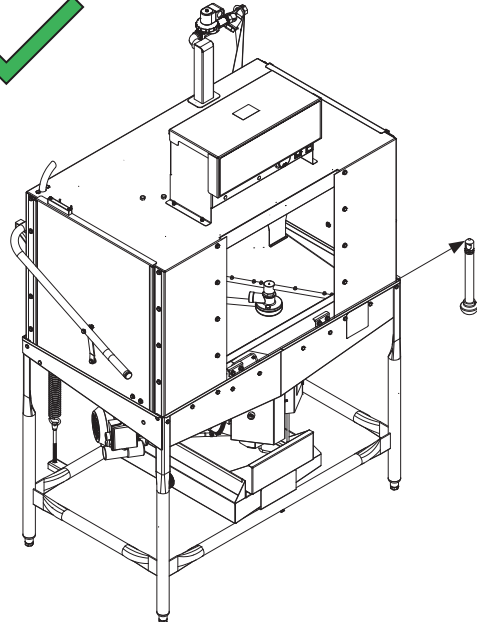

9  

