



Warewashing Systems

List Price Guide

Effective August 1, 2018



DishStar®

Undercounters



Delta®

Glasswashers



DynaTemp®
TempStar®

High Temperature Sanitizing Door-Types



Conserver®

Chemical Sanitizing Door-Types

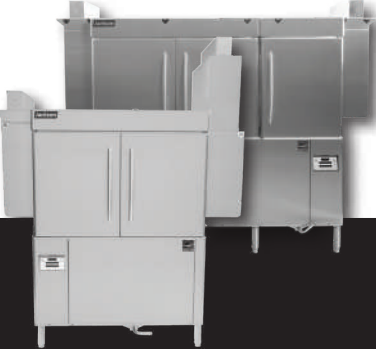

RackStar®

Conveyors



LoH₂O®

Flight-Type Machines

Clean the First Time®

Jackson WWS, Inc.

FLIGHTS / CONVEYORS / DOOR-TYPES / GLASSWASHERS / UNDERCOUNTERS

Phone: 1-888-800-5672 / Web: www.jacksonwws.com / Email: customer.service@jacksonwws.com

SEER

STEAM ELIMINATION AND ENERGY RECOVERY

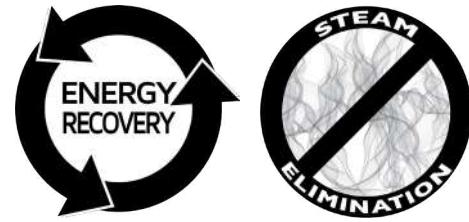

Fan extracts the hot water vapor from the chamber

Vapor passing over the coils inside the Heat Exchanger provides a 40°F rise in temperature to the water inside the coils

The now cooler vapor returns back into the chamber, and as the vapor condenses it is channeled into the wash tank

This process virtually eliminates the steam inside the chamber

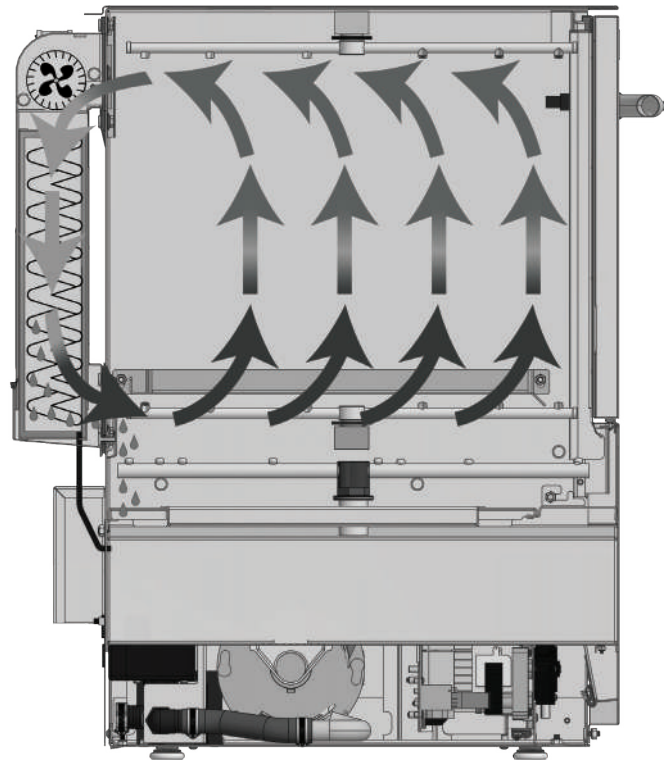

Cutaway side view of the DishStar® HT-E-SEER



DISHSTAR® HT-E-SEER

High Temperature Sanitizing Undercounter Dishmachine with Steam Elimination & Energy Recovery

Recirculating, 20 racks per hour, 0.65 gallons per rack, built-in booster heater with Sani-Sure™ final rinse system, double wall construction, stainless steel wash pump assembly, pumped drain, universal timer, digital LED control panel, three selectable cycles, delimiting cycle, built-in chemical pumps and priming switches, auto fill, auto stop, one peg and one combination rack included. 208-230/60/1



\$8,900



DISHSTAR® HT-E

High Temperature Sanitizing Undercounter Dishmachine

Recirculating, 27 racks per hour, 0.65 gallons per rack, built-in booster heater with Sani-Sure™ final rinse system, double wall construction, stainless steel wash pump assembly, pumped drain, universal timer, digital LED control panel, three selectable cycles, delimiting cycle, built-in chemical pumps and priming switches, auto fill, auto stop, one peg and one combination rack included. 208-230/60/1

\$7,665 *QUICK-SHIP*



DISHSTAR® HT

High Temperature Sanitizing Undercounter Dishmachine

Fill and dump, 24 racks per hour, 1.1 gallons per rack, built-in booster heater with Sani-Sure™ final rinse system, double-wall construction, stainless steel wash pump assembly, pumped drain, universal timer, delimiting cycle, built-in chemical pumps and priming switches, auto fill, auto stop, one peg and one combination rack included. 208-230/60/1

\$7,350 *QUICK-SHIP*



DISHSTAR® LT

Chemical Sanitizing Undercounter Dishmachine

Fill and dump, 24 racks per hour, 1.2 gallons per rack, double wall construction, stainless steel wash pump assembly, pumped drain, universal timer, delimiting cycle, low product indicator light, built-in chemical pumps and priming switches, auto stop, auto fill, one peg and one combination rack included. 115/60/1

DishStar LT
\$7,035 *QUICK-SHIP*

DishStar LTH
With Sustaining Heater
\$7,245

SEER

STEAM ELIMINATION AND ENERGY RECOVERY



DELTA® HT-E-SEER MODELS

High Temperature Sanitizing Glasswasher with Steam Elimination & Energy Recovery

Recirculating, 20 racks per hour, 0.65 gallons per rack, Soft Start, built-in booster heater with Sani-Sure™ final rinse system, double wall construction, stainless steel wash pump assembly, pumped drain, universal timer, digital LED control panel, three selectable cycles, deliming cycle, built-in chemical pumps and priming switches, auto fill, auto stop, back dress panel, one peg and one combination rack included. 208-230/60/1

Delta HT-E-SEER-T Tall/Stand Alone
\$9,300

Delta HT-E-SEER-S Short/Underbar
\$9,300

Delta HT-E-SEER Without Stand
\$8,900





DELTA® 5-E

Chemical Sanitizing Door-Type Glasswasher/ Dishwasher

Rated by NSF as both a glasswasher and a dishwasher, 40 racks per hour, 1.16 gallons per rack, accommodates glasses and wares up to 11" high, stainless steel wash pump assembly, electromechanical timer, built-in sustainer heater, easy access controls, built-in chemical pumps and priming switches, delimer switch, built-in stainless steel scrap accumulator, side enclosure panels and two half-racks included. 115/60/1

\$7,245 **QUICK-SHIP**



DELTA® ROTARY SERIES

Chemical Sanitizing Rotary-Type Glasswasher

Cleans 1,200 glasses per hour, uses 10 gallons of water per hour, single switch operation, built-in chemical pumps and priming switches, hot or cold fresh water final rinse, convenient chemical storage and easy access scrap screens. Clockwise rotation.

Delta 115 115/60/1

\$8,400 **QUICK-SHIP**

Internal storage for three one-gallon containers

Delta 1200 208-230/60/1

\$8,400 **QUICK-SHIP**



Undercounters
6" Machine Stand
M24STND-6
\$468



Undercounters
18" Machine Stand
M24STND-18
\$607



All DishStar Models & Delta HT-E-SEER Without Stand
Tie Down
06401-002-40-56
\$221



1/2"
Water Hammer Arrestor
05700-002-64-67
\$276



Scale Prevention Sys (SPS)
04730-003-28-03
\$634



Cartridge for SPS
04730-003-28-04
\$551



Delta 1200 & 115
Scrap Tray
06401-031-66-21
\$331

1/2" Pressure Regulator 04820-100-04-07.....	\$198
Drain Water Tempering Kit 06401-004-59-11 (High-temp DishStars & High-temp Deltas) ..	\$386
06401-004-56-12 (DishStar 460v)	\$386
Back Panel 05700-004-23-52 (DishStar HT-E)	\$221
05700-003-33-55 (DishStar HT & LT)	\$221
05700-004-58-14 (DishStar HT-E-SEER) ..	\$221
Casters (set of 4) 05700-002-37-82.....	\$110
460V Electrical (DishStar HT-E)	\$684
Sustaining Heater (DishStar LT)	\$210
Security Package	\$1,654

DYNATEMP®

High Temperature Sanitizing Door-Type Dishmachine

Single rack, electric tank heat, built-in booster heater with Sani-Sure™ final rinse system, 57 racks per hour, 0.69 gallons per rack, bottom mounted digital LED controls, universal timer, Triple Wash Arm, self-draining stainless steel wash pump, three selectable wash cycles, delimer switch, auto start/stop, exhaust vent fan control, field convertible for straight-through to corner and vice versa, field phase conversion capability. 208-230v, 60Hz, single or three phase.



DynaTemp

Electric Tank Heat with
40-70° Rise Booster Heater

\$14,700 **QUICK-SHIP**

DynaTemp VER

Electric Tank Heat with Booster Heater
and Ventless & Energy Recovery

\$18,900

DynaTemp W/O*

Electric Tank Heat
without Booster Heater

\$12,600

DynaTemp STH*

Steam Tank Heat
(Steam Booster Heater Sold Separately)

\$13,650

*Requires 180° F incoming water



TEMPSTAR®

High Temperature Sanitizing Door-Type Dishmachine

Single rack, electric tank heat, built-in booster heater with Sani-Sure™ final rinse system, 58 racks per hour, 0.89 gallons per rack, universal timer, self-draining stainless steel wash pump, four selectable wash cycles, top mounted controls, delimer switch, auto start/stop, exhaust vent fan control, field convertible for straight-through to corner and vice versa, field phase conversion capability, front stainless steel dress panel. 208-230v, 60Hz, single or three phase.

TempStar

Electric Tank Heat with
40 or 70° Rise Booster Heater

\$13,781

TempStar STH*

Steam Tank Heat (Steam
Booster Heater Sold Separately)

\$12,569

TempStar W/O*

Electric Tank Heat
without Booster Heater

\$11,687

TempStar GPX

Gas Tank Heat with
External Gas Booster Heater

\$24,145



TEMPSTAR®

WITH VENTLESS & ENERGY RECOVERY

High Temperature Sanitizing Door-Type Dishmachine

No vent hood required. Accommodates a wide range of water inlet temperatures and operates with only a cold water connection. Single rack, electric tank heat, built-in booster heater with Sani-Sure™ final rinse system, 39 racks per hour, 0.89 gallons per rack, universal timer, self-draining stainless steel wash pump, four selectable wash cycles, top mounted controls, delimer switch, auto start/stop, door interlock, pressure regulator, exhaust vent fan control, field convertible for straight-through to corner and vice versa, field conversion capability, front stainless steel dress panel. 208-230v, 60Hz, single or three phase.



TempStar Ventless

Electric Tank Heat with Booster Heater
and Ventless & Energy Recovery

\$18,191

*Requires 180° F incoming water



TEMPSTAR® HH-E

High Temperature Sanitizing Door-Type Dishmachine with Tall Chamber

Single rack, electric tank heat, built-in booster heater with Sani-Sure™ final rinse system, 27" clearance for larger wares, 55 racks per hour, 0.72 gallons per rack, dual counter-rotating lower wash arms, universal timer, self-draining stainless steel wash pump, four selectable wash cycles, top mounted controls, delimer switch, auto start/stop, exhaust vent fan control, field convertible for straight-through to corner and vice versa, front stainless steel dress panel. 208-230v, 60Hz, single or three phase.

TempStar HH-E

Electric Tank Heat with
40 or 70° Rise Booster Heater

\$16,538

TempStar HH-E W/O*

Electric Tank Heat
without Booster Heater

\$14,443

TempStar HH STH*

Steam Tank Heat (Steam
Booster Heater Sold Separately)

\$15,325

(1.36 gph)

TempStar HH GPX

Gas Tank Heat with
External Gas Booster Heater

\$28,665

(1.36 gph)



TEMPSTAR® HH-E WITH VENTLESS & ENERGY RECOVERY

High Temperature Sanitizing Door-Type Dishmachine with Tall Chamber

No vent hood required. Accommodates a wide range of water inlet temperatures and operates with only a cold water connection. Single rack, electric tank heat, built-in booster heater with Sani-Sure™ final rinse system, 27" clearance for larger wares, 37 racks per hour, 0.72 gallons per rack, dual counter-rotating lower wash arms, universal timer, self-draining stainless steel wash pump, four selectable wash cycles, top mounted controls, delimer switch, auto start/stop, door interlock, pressure regulator, exhaust vent fan control, field convertible for straight-through to corner and vice versa, front stainless steel dress panel. 208-230v, 60Hz, single or three phase.



TempStar HH-E Ventless

Electric Tank Heat with Booster Heater
and Ventless & Energy Recovery

\$20,948



*Requires 180° F incoming water

DynaTemp® & TempStar® Series Options & Accessories

 <p>1/2"</p> <p>All DynaTemp Models, TempStar, TempStar W/O, TempStar HH-E, TempStar HH-E W/O, TempStar GPX Models</p> <p>Water Hammer Arrestor 05700-002-64-67 \$276</p>	 <p>3/4"</p> <p>TempStar Steam Models</p> <p>Water Hammer Arrestor 05700-002-61-29 \$276</p>	 <p>DynaTemp Models</p> <p>False Panel Kit 05700-004-44-38 \$221</p>	 <p>TempStar Models</p> <p>False Panel 05700-002-75-59 \$221</p>	 <p>TempStar HH Models</p> <p>False Panel 05700-002-52-89 \$276</p>	 <p>Steam Booster Heater 05700-002-98-86 \$5,733</p>
 <p>DynaTemp Models</p> <p>Flanged Feet (set of 4) 05700-004-29-44 \$221</p>	 <p>TempStar Models</p> <p>Flanged Feet (set of 4) 05340-002-34-86 \$221</p>	 <p>TempStar HH Models</p> <p>Flanged Feet (set of 4) 05340-002-01-15 \$221</p>	 <p>All DynaTemp Models, TempStar, TempStar W/O, TempStar HH-E, TempStar HH-E W/O</p> <p>1/2" Pressure Regulator 04820-100-04-07 \$198</p>	 <p>TempStar Steam Models, TempStar GPX Models</p> <p>3/4" Pressure Regulator 06685-011-58-22 \$221</p>	 <p>Drain Water Tempering Kit DynaTemp 06401-004-39-54 TempStar 06401-004-07-86 \$772</p>
 <p>Scaltrol Water Treatment 04730-003-05-76 \$386</p>			<p>460V Electrical \$684 50 Hz Cycle \$1,158 208-230/60/1 N/C</p> <p>External Exhaust Fan Contactor Kit 05700-004-35-35 \$168</p> <p>Door Interlock 05700-002-35-4 \$1,158</p> <p>Security Package \$2,756</p>		 <p>Cartridge for Scaltrol RSC-100 \$303</p>



MODEL 10 A





Round Dishmachine

High-temperature sanitizing dishmachine, 45 racks per hour, counter-rotating wash arms, manual control back-up system, 17 1/4" inside chamber clearance, wash and rinse temperature gauges, external vacuum breaker, requires 180° F incoming water supply (optional booster heater available). 208 or 230, single or three phase, 60Hz.

\$16,800

- Model 10 AB** Model 10 A plus 6.5kW Built-in Booster Heater (70°F rise) **\$18,900**
- Model 10 U** Model 10 AB for Undercounter Installation **\$17,850**
- Model 10 APRB** Model 10 AB plus 1/2 hp Final Rinse Pump **\$21,000**
- Model 10 AB/NSU** Model 10 AB, 440/60/3 **\$25,200**
- Model 10 AB-N70** Model 10 AB plus 7.7kW Built-in Booster Heater (70°F rise), 440/60/3... **\$26,250**

Model 10 Options & Accessories

 <p>Round Peg Rack 07320-100-09-01 \$276</p>	 <p>Round Combination Rack 07320-100-13-01 \$221</p>	 <p>Round 12-Compartment 07320-100-17-01 \$276</p>	 <p>Silverware</p> <p>6-Compartment Basket 07320-100-08-01 \$110</p>
---	---	---	---

Higher Hood
\$1,050



CONSERVER® XL-E

Chemical Sanitizing Single Rack Door-Type Dishmachine

Cleans 39 racks per hour, 1.02 gallons per rack, self-draining stainless steel wash pump assembly, electromechanical timer, top mounted controls, delimer switch, low product indicator light, built-in chemical pumps and priming switches, interchangeable upper and lower stainless steel wash/rinse arms, field convertible from straight-through to corner and vice versa, auto start/stop, built-in stainless steel waste accumulator, internal sump. 115/60/1

Conserver XL-E

\$6,064 *QUICK-SHIP*

Conserver XL-E-LTH

*With Booster Heater;
208-230, 60Hz, single or three phase*

\$8,164

*Booster heater ensures
a continuous supply
of 145°F water for
excellent results*



CONSERVER® XL HH

Chemical Sanitizing Single Rack Door-Type Dishmachine with Tall Chamber

Cleans 39 racks per hour, 1.61 gallons per rack, 27" clearance for larger wares, self-draining stainless steel wash pump assembly, electromechanical timer, top mounted controls, delimer switch, low product indicator light, built-in chemical pumps and priming switches, interchangeable upper and lower stainless steel wash/rinse arms, field convertible from straight-through to corner and vice versa, auto start/stop, built-in stainless steel waste accumulator, internal sump. 115/60/1

Conserver XL HH

\$7,875

CONSERVER® XL2

Chemical Sanitizing Dual Rack Door-Type Dishmachine

Dual rack straight, 74 racks per hour, 1.17 gallons per rack, self-draining stainless steel wash pump assemblies, electromechanical timer, top mounted controls, delimer switch, low product indicator light, built-in chemical pumps and priming switches, interchangeable upper and lower stainless steel wash/rinse arms, auto start/stop, built-in stainless steel scrap accumulator, internal sump. 115/60/1



Conserver XL2
\$9,041

Conserver XL2C
\$9,592

Same specifications as the Conserver XL2, except for corner installations. Specify right front (R) or left front (L) door opening.

Conserver® Series Options & Accessories



Water Hammer Arrestor
05700-002-61-29
\$276



Conserver XL-E False Panel
05700-002-51-66
\$221



Conserver XL HH False Panel
05700-002-52-89
\$276



Flanged Feet (set of 4)
05340-002-34-86
\$221



3/4" Pressure Regulator
06685-011-58-22
\$221

Low Product Audible Alarm
06401-003-93-47
\$221

50Hz Cycle
\$1,158

230/60/1
\$607



Scaltrol Water Treatment
04730-003-05-76
\$386



Cartridge for Scaltrol RSC-100
\$303

RackStar® 44

44" Single Tank Conveyor Dishmachine

Single tank conveyor dishmachine, high temperature or chemical sanitizing, 223 racks per hour, adjustable rinse - Econo (0.35 gallons per rack) or Turbo (0.51 gallons per rack) - with exclusive Rainbow Rinse™ arms, adjustable vent cowl collars, hinged doors with large front access for ease of maintenance, bottom mounted digital LED controls, universal timer, dual-pawl conveyor drive system, EnergyGuard™ system, 19-3/4" standard chamber height, automatic fill, delimer switch, whisper-quiet stainless steel pump assembly, exhaust vent fan control, 15' strike plate table limit switch. 208-230v, 60Hz, single or three phase.

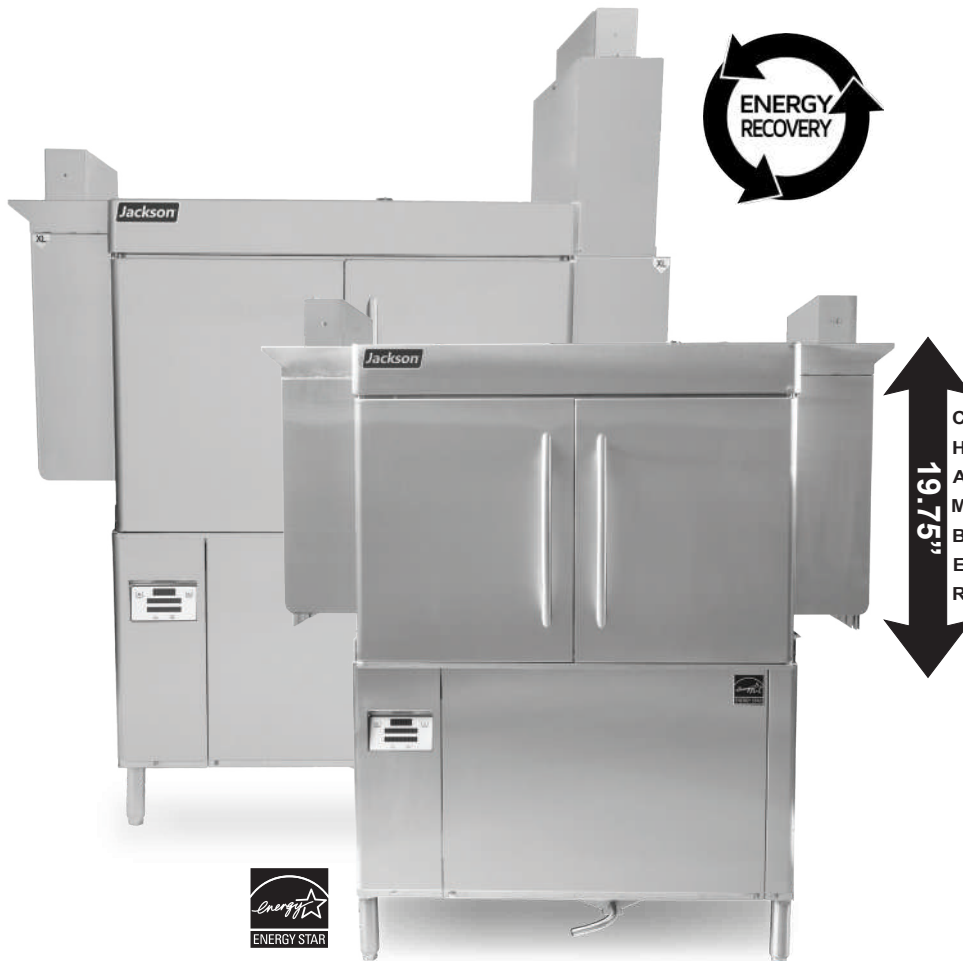

RackStar 44CE/CEL
Electric Tank Heat - High Temperature
Sanitizing or Chemical Sanitizing
(Electric Booster Heater Sold Separately)

\$22,601

RackStar 44CS
Steam Tank Heat (Steam Booster
Heater Sold Separately)

\$24,255

**RackStar 44CE
Energy Recovery**
Electric Tank Heat with a Built-in 27kW
Booster Heater and Energy Recovery

\$31,201

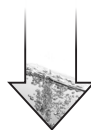

Less Water



Less Chemicals



Less Energy

Machine	Racks/Hour	Gallons/Rack	Gallons/Hour	Booster Heater 40°F/70°F
Brand H 44	202	0.62	125	15kW/30kW
Brand C 44	209	0.48	100	12kW/21kW
Brand S 44	232	0.50	116	12kW/24kW
Brand M 44	239	0.43	103	15kW/27kW
RackStar 44	223	0.35	78	12kW/18kW

RackStar® 66

66" Single Tank Conveyor Dishmachine (44"+ 22" Pre-Wash)

Single tank conveyor dishmachine with 22" pre-wash, high temperature or chemical sanitizing, 223 racks per hour, adjustable rinse - Econo (0.35 gallons per rack) or Turbo (0.51 gallons per rack) - with exclusive Rainbow Rinse™ arms, adjustable vent cowl collars, hinged doors with large front access for ease of maintenance, bottom mounted digital LED controls, universal timer, dual-pawl conveyor drive system, EnergyGuard™ system, 19-3/4" standard chamber height, automatic fill, delimer switch, whisper-quiet stainless steel pump assembly, exhaust vent fan control, 15' strike plate table limit switch. 208-230v, 60Hz, single or three phase.

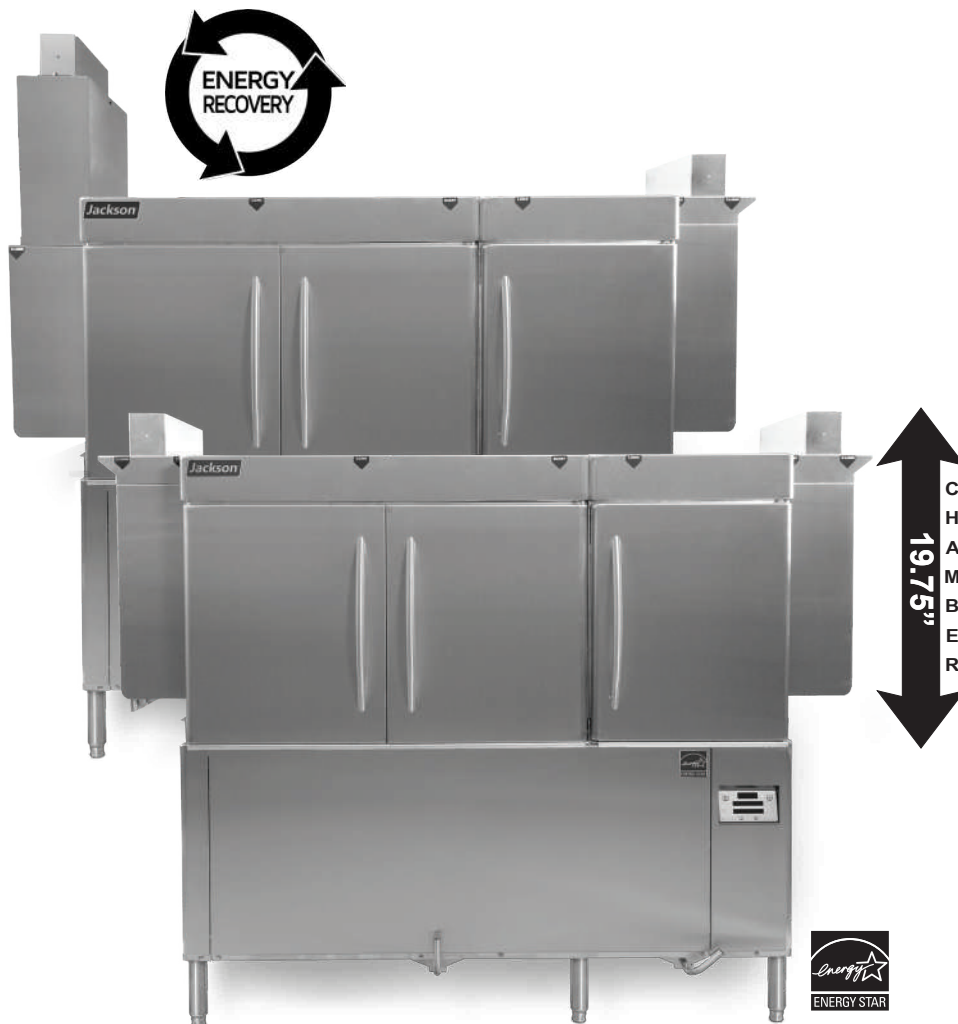

RackStar 66CE/CEL
 Electric Tank Heat - High Temperature
 Sanitizing or Chemical Sanitizing
 (Electric Booster Heater Sold Separately)
\$33,626

RackStar 66CS
 Steam Tank Heat (Steam Booster
 Heater Sold Separately)
\$35,280

**RackStar 66CE
 Energy Recovery**
 Electric Tank Heat with a Built-in 27kW
 Booster Heater and Energy Recovery
\$42,226

RackStar® Series (only) Options & Accessories

A full listing of conveyor options and accessories is located on page 16

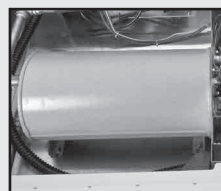

Onboard Booster Heater
 70° F rise/18kW
\$3,308

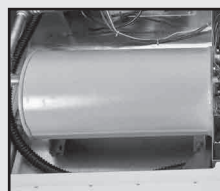

Onboard Booster Heater
 40° F rise/12kW
\$2,756

**Single Point
 Connection**
 Available on RackStar
 Conveyors with onboard
 boosters -
 no upcharge applies.*

*3-phase machines only



1/2" Pressure Regulator
 04820-100-04-07
\$198

AJX-44 SERIES

Single Tank Conveyor Dishmachine

Single tank conveyor dishmachine, high temperature or chemical sanitizing, 225 racks per hour and 0.68 gallons per rack for high temperature, 209 racks per hour and 0.78 gallons per rack for chemical sanitizing, Adjust-A-Peak™ conveyor speed, EnergyGuard™ system, 25" tall chamber height, automatic fill, top mounted controls, manual/automatic switch, whisper-quiet stainless steel pump assembly, exhaust vent fan control. 208-230v, 60Hz, single or three phase.

AJX-44

44" Conveyor

AJX-44CE/CEL

Electric Tank Heat - High Temperature Sanitizing or Chemical Sanitizing
(Electric Booster Heater Sold Separately)

\$20,396

AJX-44CS

Steam Tank Heat (Steam Booster Heater Sold Separately)

\$22,050

AJX-66

66" Conveyor (44" + 22" Pre-Wash)

AJX-66CE/CEL

Electric Tank Heat - High Temperature Sanitizing or Chemical Sanitizing
(Electric Booster Heater Sold Separately)

\$31,425

AJX-66CS

Steam Tank Heat (Steam Booster Heater Sold Separately)

\$33,626

AJX-80

80" Conveyor (44" + 36" Pre-Wash)

AJX-80CE/CEL

Electric Tank Heat - High Temperature Sanitizing or Chemical Sanitizing
(Electric Booster Heater Sold Separately)

\$34,729

AJX-80CS

Steam Tank Heat (Steam Booster Heater Sold Separately)

\$36,383

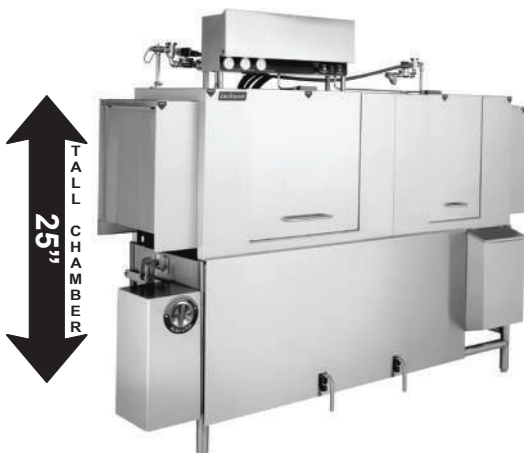

AJX-54 SERIES

Single Tank Conveyor Dishmachine

Single tank conveyor dishmachine, dual rated for both high temperature and chemical sanitizing, 225 racks per hour and 0.68 gallons per rack for high temperature, 209 racks per hour and 0.78 gallons per rack for chemical sanitizing, Adjust-A-Peak™ conveyor speed, EnergyGuard™ system, 25" tall chamber height, automatic fill, top mounted controls, manual/automatic switch, whisper-quiet stainless steel pump assembly, exhaust vent fan control. 208-230v, 60Hz, single or three phase.



AJX-54

54" Conveyor

AJX-54CE/CEL

Electric Tank Heat - High Temperature Sanitizing or Chemical Sanitizing
(Electric Booster Heater Sold Separately)

\$27,563

AJX-54CS

Steam Tank Heat (Steam Booster Heater Sold Separately)

\$29,216

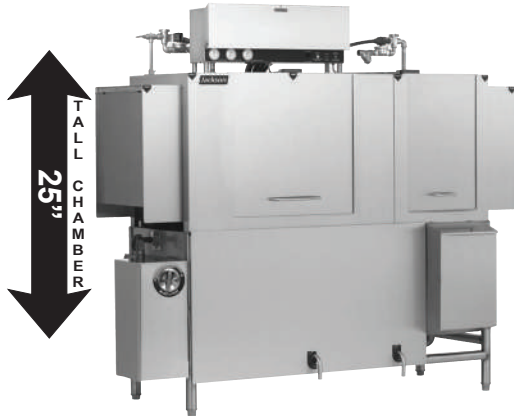

AJX-76

76" Conveyor (54" + 22" Pre-Wash)

AJX-76CE/CEL

Electric Tank Heat - High Temperature Sanitizing or Chemical Sanitizing
(Electric Booster Heater Sold Separately)

\$40,793

AJX-76CS

Steam Tank Heat (Steam Booster Heater Sold Separately)

\$42,998

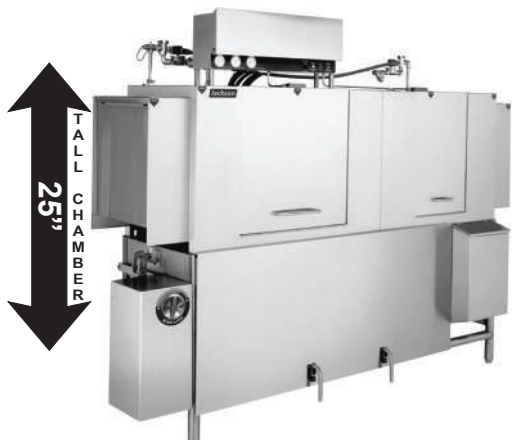

AJX-90

90" Conveyor (54" + 36" Pre-Wash)

AJX-90CE/CEL

Electric Tank Heat - High Temperature Sanitizing or Chemical Sanitizing
(Electric Booster Heater Sold Separately)

\$44,100

AJX-90CS

Steam Tank Heat (Steam Booster Heater Sold Separately)

\$46,305

AJ-44 SERIES

Single Tank Conveyor Dishmachine with Gas Tank Heat

Single tank, gas tank heat conveyor dishmachine, 248 racks per hour and 0.94 gallons per rack, Adjust-A-Peak™ conveyor speed, EnergyGuard™ system, 25" tall chamber height, automatic fill, top mounted controls, manual/automatic switch, whisper-quiet stainless steel pump assembly, exhaust vent fan control. Includes external booster heater. 208-230v, 60Hz, single or three phase.



AJ-44CGP

44" Single Tank Conveyor

Gas Tank Heat with External Gas Booster Heater

\$39,690

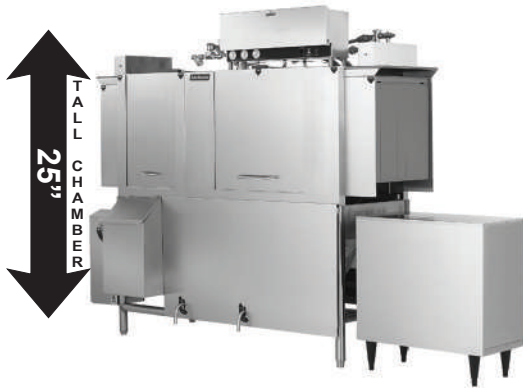

AJ-66CGP

66" Single Tank Conveyor (44" + 22" Pre-Wash)

Gas Tank Heat with External Gas Booster Heater

\$51,818

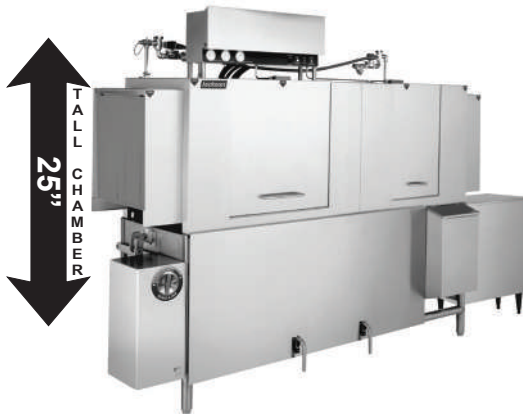

AJ-80CGP

80" Single Tank Conveyor (44" + 36" Pre-Wash)

Gas Tank Heat with External Gas Booster Heater

\$55,125

AJ-64 SERIES

Dual Tank Conveyor Dishmachine

Dual tank conveyor dishmachine, high temperature sanitizing, 287 racks per hour and 0.77 gallons per rack, Adjust-A-Peak™ conveyor speed, EnergyGuard™ system, 25" tall chamber height, automatic fill, top mounted controls, manual/automatic switch, whisper-quiet stainless steel pump assembly, exhaust vent fan control. 208 or 230v, 60Hz, single or three phase.

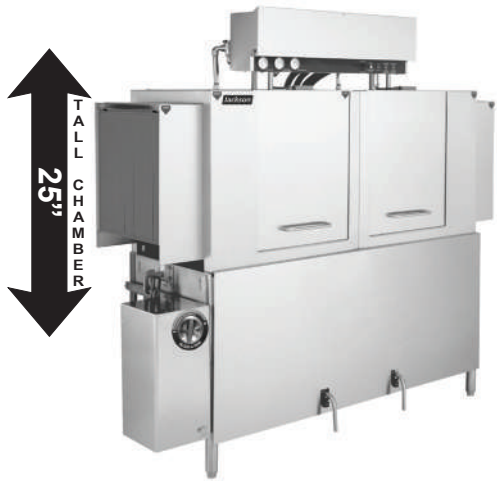

AJ-64

64" Dual Tank Conveyor

AJ-64CE

Electric Tank Heat - High Temperature Sanitizing (Electric Booster Heater Sold Separately)

\$41,895

AJ-64CS

Steam Tank Heat (Steam Booster Heater Sold Separately)

\$44,100

AJ-64CGP

Gas Tank Heat with External Gas Booster Heater

\$59,535

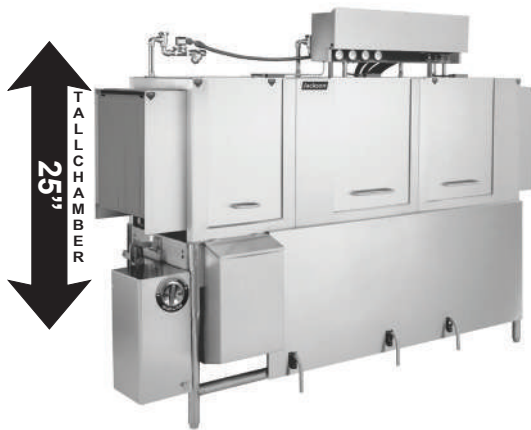

AJ-86

86" Dual Tank Conveyor (64" + 22" Pre-Wash)

AJ-86CE

Electric Tank Heat - High Temperature Sanitizing (Electric Booster Heater Sold Separately)

\$55,125

AJ-86CS

Steam Tank Heat (Steam Booster Heater Sold Separately)

\$57,330

AJ-86CGP

Gas Tank Heat with External Gas Booster Heater

\$71,663

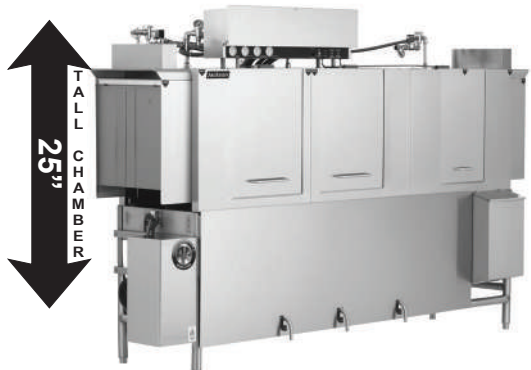

AJ-100

100" Dual Tank Conveyor (64" + 36" Pre-Wash)

AJ-100CE

Electric Tank Heat - High Temperature Sanitizing (Electric Booster Heater Sold Separately)

\$57,330

AJ-100CS

Steam Tank Heat (Steam Booster Heater Sold Separately)

\$59,535

AJ-100CGP

Gas Tank Heat with External Gas Booster Heater

\$74,970

Conveyor Options & Accessories



RackStar Models

Onboard Booster Heater

70° F rise/18kW **\$3,308**

40° F rise/12kW **\$2,756**



Flanged Feet

05340-002-15-47

\$331



AJX & AJ Models

Vent Cowl Collar

05700-002-04-08

\$441



RackStar & AJX Models

Water Hammer Arrestor

05700-002-64-67

\$276



AJ Models

Water Hammer Arrestor

05700-002-61-29

\$276



Steam Booster Heater

05700-002-98-86

\$5,733



Drain Water Tempering Kit

06401-002-44-07

\$1,020

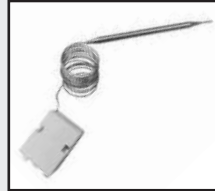

Cold Water Thermostat

05930-121-75-66

\$441



Table Limit Switch

05700-002-88-07 Strike Plate

\$386 (shown)

05700-002-06-83 Whisker Switch

\$386



Scaltrrol Water Treatment

04730-003-05-76

\$386



Cartridge for Scaltrrol

RSC-100

\$303

460V Electrical	All models	\$1,048
50Hz Cycle	AJX & AJ models	\$1,048
Dual Point Connection	AJX & AJ models	\$689
Single Point Connection	RackStar with onboard booster, 3-phase only.....	N/C
1/2" Pressure Regulator	04820-100-04-07 (RackStar and AJX models)	\$198
3/4" Pressure Regulator	06685-011-58-22 (AJ models).....	\$221
External Exhaust Fan Contactor Kit	05700-004-35-35	\$168
Side Loader	23" Unhooded	\$5,513
Side Loader	23" Hooded (25" models).....	\$7,938
Side Loader	30" Unhooded	\$7,938
Side Loader	30" Hooded (25" models).....	\$9,041
Blower Dryer	AJX & AJ models	\$11,025
Security Package	All conveyor models.....	\$4,961

Electric Booster Heaters

C-4 Hatco® 4kW	\$2,746	C-18 Hatco® 18kW	\$3,181
C-6 Hatco® 6kW	\$2,836	C-24 Hatco® 24kW	\$4,236
C-7 Hatco® 7kW	\$2,871	C-27 Hatco® 27kW	\$4,296
C-9 Hatco® 9kW	\$2,906	C-30 Hatco® 30kW	\$4,341
C-12 Hatco® 12kW	\$3,076	C-36 Hatco® 36kW	\$4,546
C-15 Hatco® 15kW	\$3,131	C-45 Hatco® 45kW	\$5,146
C-17 Hatco® 17.2kW.....	\$3,156	C-54 Hatco® 54kW	\$5,296

Recommended Booster Heater Sizing Chart

TEMPERATURE	RackStar 44/66	AJX-44/54	AJ-64	AJX-66/76	AJX-80/90	AJ-86	AJ-100
40°F RISE	C-12	C-17	C-36	C-17	C-17	C-36	C-36
70°F RISE	C-17/C-18*	C-30	C-45	C-30	C-30	C-45	C-45

*Booster size determined by voltage and phase. Contact Customer Service for further assistance.

CONVEYOR DIRECTION OF OPERATION

When ordering a conveyor dishmachine, it is important to specify not only the size, voltage, and any options and accessories needed, but it is also **EXTREMELY** important that the Direction of Operation is properly specified. If unsure, please use the drawings below to determine the correct Direction of Operation of your new conveyor dishmachine.



FLIGHT-TYPE MACHINES



LoH₂O[®] Rackless Conveyor Dishmachine



Rainbow Rinse™ produces superior results while significantly reducing water consumption



Specially designed wash arms with non-clogging, convex jets provide equalized water pressure and uniform cleanability



Reliable electromechanical controls and digital temperature readouts for each wash tank and final rinse

Rackless conveyor, cleans 11,094 dishes per hour, 58 gallons of water per hour, Rainbow Rinse™ final rinse arm, non-clogging wash and rinse arm nozzles, sequential digital temperature readout of each tank, door safety switches, belt tension adjustment, large removable scrap screens.

Also available in our 139.2 gallon/14,964 dishes per hour model - JFT

Assembly of all flight sections - including internal wiring, piping, thermometers and leveling of the machine - is performed by Jackson factory-authorized personnel. The Jackson factory authorized personnel will also conduct a performance test and operator training at time of assembly. Final utility connections for plumbing and electrical shall be provided by others and should be conducted by an authorized and licensed tradesman in accordance with local, state and national building codes and guidelines. All Jackson Flight-Type machines come with a one-year Parts & Labor Warranty and a two-year Preventative Maintenance Program (PMP) through the local Jackson Authorized Service Agency (ASA).

Call Factory for Quote

WATER TREATMENT



Scale Prevention Sys (SPS)
04730-003-28-03
\$634



Cartridge for SPS
04730-003-28-04
\$551



Scaltrol Water Treatment
04730-003-05-76
\$386



Cartridge for Scaltrol
RSC-100
\$303

DISHTABLES

DTC-S70-24L	Clean Side 24" - Left side installation	\$1,426	DTS-S70-36L	Soil Side 36" - Left side installation	\$2,576
DTC-S70-24R	Clean Side 24" - Right side installation...	\$1,426	DTS-S70-36R	Soil Side 36" - Right side installation	\$2,576
DTC-S70-36L	Clean Side 36" - Left side installation	\$1,636	DTS-S70-48L	Soil Side 48" - Left side installation	\$2,663
DTC-S70-36R	Clean Side 36" - Right side installation...	\$1,636	DTS-S70-48R	Soil Side 48" - Right side installation	\$2,663
DTC-S70-48L	Clean Side 48" - Left side installation	\$1,781	DTS-S70-72L	Soil Side 72" - Left side installation	\$2,892
DTC-S70-48R	Clean Side 48" - Right side installation...	\$1,781	DTS-S70-72R	Soil Side 72" - Right side installation	\$2,892
DTC-S70-72L	Clean Side 72" - Left side installation	\$1,978	DTU-U60-48L	Undercounter Table 48" - Left side.....	\$2,467
DTC-S70-72R	Clean Side 72" - Right side installation...	\$1,978	DTU-U60-48R	Undercounter Table 48" - Right side	\$2,467

Please Call Factory for Custom Dishtable Sizes & Specifications

DISHTABLE ACCESSORIES

B-2147M	Pre-Rinse Spray for use with Overshelf	\$634	DT-6R-22-X	Overshelf 42"	\$982
B-2175M	Pre-Rinse Spray for use w/o Overshelf	\$634	DT-6R-23-X	Overshelf 62"	\$1,092
07320-500-01-04	Scrap Block.....	\$292	DTA-100-X	Pre-Rinse Basket with Slide Bar	\$551
DTA-SS-42	Undershelf 42"	\$982			

DISH RACKS



20x20 Combination Rack
07320-100-36-00
\$105



20x20 Peg Rack
07320-100-35-00
\$105



4-1/8" Tall
36-Compartment Rack
07320-002-86-70
\$105



5-5/8" Tall
36-Compartment Rack
07320-002-86-71
\$122

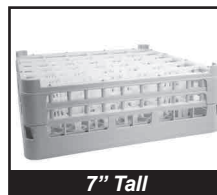

7" Tall
36-Compartment Rack
07320-002-86-72
\$127



Delta 5-E
Half Rack
07320-002-76-80
\$56



Door-Type HH Models
Sheet Pan Rack
5010-BP
\$342



Conveyors
Sheet Pan Rack
5010-LS
\$342



Round Peg Rack
07320-100-09-01
\$276



Round Combination Rack
07320-100-13-01
\$221

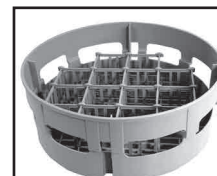

Round 12-Compartment
07320-100-17-01
\$276



Silverware
6-Compartment Basket
07320-100-08-01
\$110

GENERAL INFORMATION

TERMS OF SALE: Net 30 days.

FREIGHT TERMS: F.O.B. Factory prepaid and allowed in the contiguous United States on Jackson manufactured dishmachines, subject to the following surcharges:

Lift-Gate Delivery (44" & smaller).....	\$75	Inside Delivery (44" & smaller).....	\$75
Call Prior to Delivery	\$50	Re-Consignment.....	\$75
Guaranteed Delivery Date	Call Factory	Export or Special Packaging ...	Call Factory

QUICK-SHIP PROGRAM: All items marked with  are part of Jackson's Quick Ship Program. Standard shipping for these products is 1 to 2 business days. Please contact Jackson Customer Service for lead times on all other products.

RETURNS: All returns must be authorized in writing by Jackson and are subject to a 25% restocking fee and freight charges both ways.

ALL PRICES ARE IN U.S. DOLLARS.

ALL PRICES, TERMS, ITEMS & SPECIFICATIONS ARE SUBJECT TO CHANGE WITHOUT NOTICE.

FOR SPECIFIC DETAILS REGARDING PRODUCT SPECIFICATIONS, DIMENSIONS AND CERTIFICATIONS, PLEASE REFER TO THE PRODUCT SPECIFICATION SHEET FOR THE INDIVIDUAL MODEL.

GENERAL INFORMATION

WARRANTY/EXTENDED WARRANTY: All new Jackson manufactured dishmachines are warranted to the original purchaser to be free from defects in material and workmanship, under normal use and operation, for a period of one (1) year from the date of purchase, in the 50 United States of America. Extended warranties are available on new Jackson manufactured dishmachines and must be purchased at the time of equipment order. A one (1) year extended warranty is available at a rate of 6% of the machine's list price and a two (2) year extended warranty is available at a rate of 11% of the machine's list price.



FREE START-UP: All new Jackson manufactured dishmachines qualify for a Complimentary Performance & Installation Check by a Jackson Authorized Service Agency (ASA)*. When the machine is installed by a Jackson ASA, this complimentary service is provided at the time of installation.

When the installation is not performed by the local Jackson ASA we will still conduct the Complimentary Performance & Installation Check to verify the installation was done correctly and that the machine is operating properly. Contact Jackson Technical Service to arrange for this service.

**Jackson WWS limits travel time to two (2) hours and mileage to one hundred (100) miles round trip. Jackson WWS will not pay for travel time and mileage that exceed this, or any fees such as those for air or boat travel without prior authorization. For machines located beyond the above stated limitations, please contact Jackson Technical Service for assistance via phone, 1-888-800-5672.*

ABOUT JACKSON

Jackson WWS is a full-line supplier of high-quality commercial dishmachines including flights, conveyors, door-types, glasswashers and undercounters. Founded in 1925, Jackson stands by their “Clean the First Time[®]” commitment with dishmachines that deliver optimal cleaning performance while reducing labor, chemical and utility costs. With more standard features, lower operating and acquisition costs and our network of factory-certified technicians, Jackson sets the standard for warewashing. For more information about Jackson and its full line of warewashing solutions, please visit www.jacksonwws.com or call 1.888.800.5672.



Jackson WWS List Price Guide
August 1, 2018

Jackson WWS, Inc.

Shipping Address: 6209 North U.S. Highway 25E, Gray, KY 40734
Mailing Address: P.O. Box 1060, Barbourville, KY 40906
Telephone: 888-800-5672 • Fax: 606-523-1799
Email: customer.service@jacksonwws.com
07610-003-59-42 [08/01/18]

www.jacksonwws.com



CLICK or SCAN
to access the
Jackson website