



The manufacturer does not cover the installation of table limit switches. If installed incorrectly, the manufacturer is not responsible for any damage.

DESCRIPTION

Conveyer dishmachines automatically push racks through the machine as they are washed. This continues even after there is no more space on the dish table, which can lead to broken racks, dishes, glasses, etc. The Striker Plate Table Limit Switch avoids this damage by cutting power to the conveyer motor coil and stopping the conveyer when the table is full.

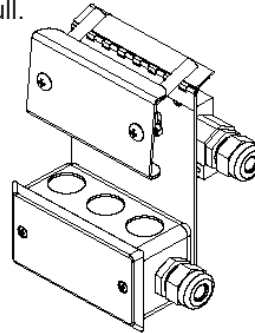
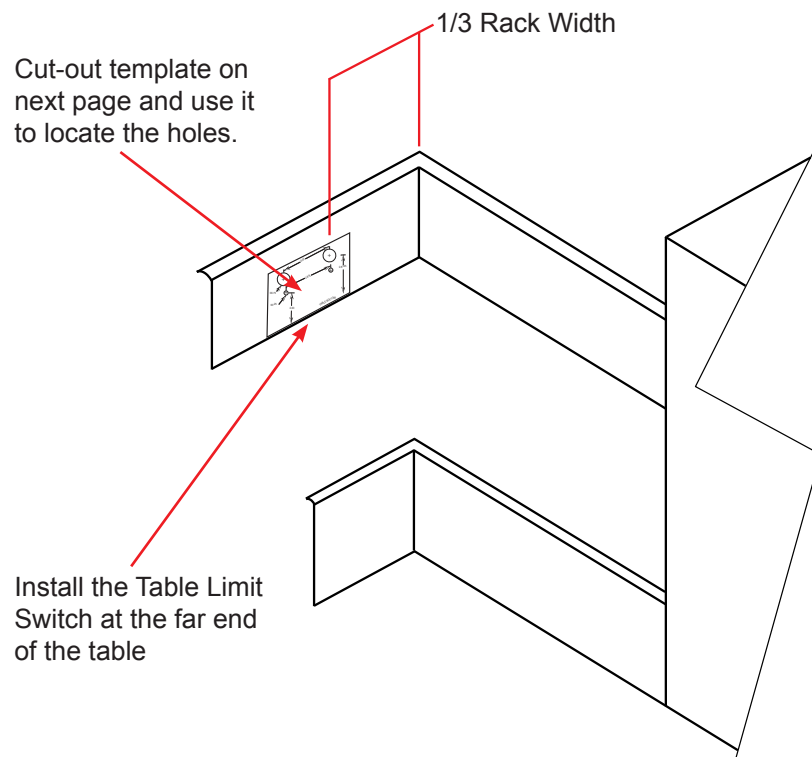
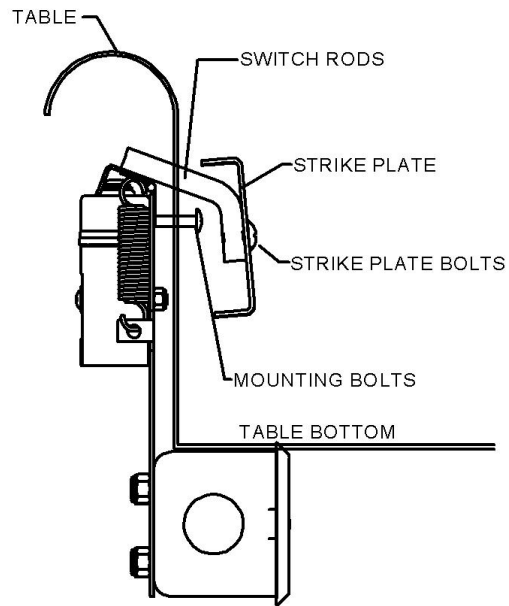

TABLE PREPARATION

The switch should be installed where it will allow the maximum number of racks on the clean end of the dish table, and where it will be tripped by all of the various types of racks used at that location. Determine the path of the racks and locate the contact point of the switch about 1/3 of a rack width from the side of the table (see drawing).



MOUNTING Parts of the table switch are mounted on the dish table, at the end of the table, and under the table. See drawing for relationship of switch to table. Move limit switch as far down on the two slots as possible and ensure the limit switch is straight on the base plate. This might require adjustment of the nut of the connector for the limit switch. Then adjust the inside and outside connector nuts for the connector box so that it lines up even with the limit switch and the base plate. Tighten down the nuts for the seal tight. If you have any difficulty you might have to adjust the connectors to the seal tight, screwing in or out until the installation is straight on the table and the limit switch is actuated correctly by the rack.



The wall height of the dish table affects the location of the limit switch.

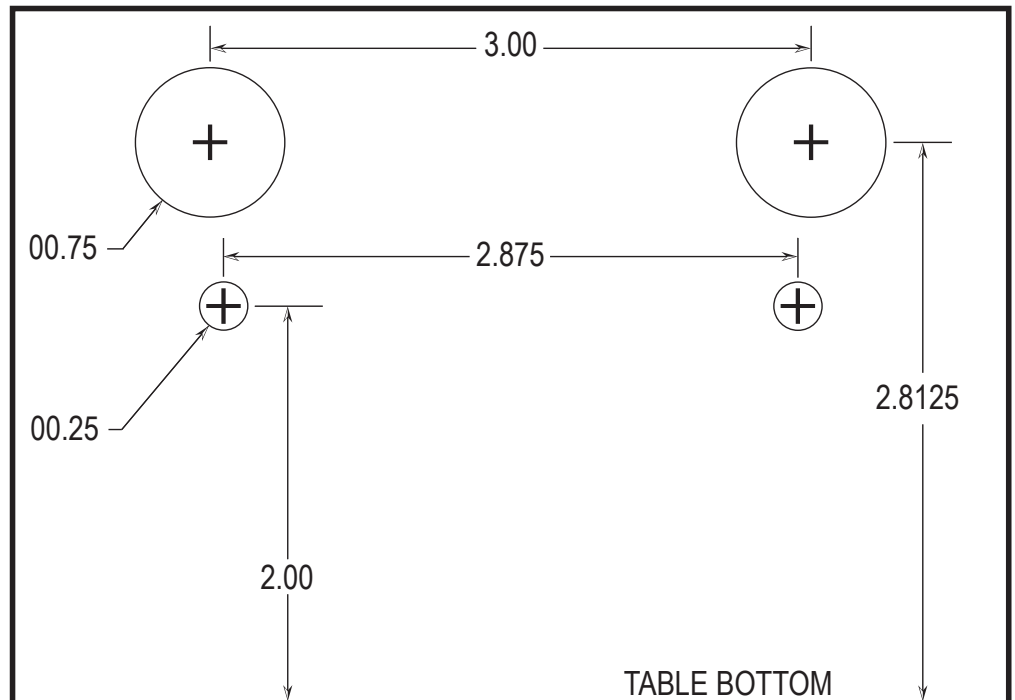

Cut-out template and use it to locate the holes to be drilled in the table.

WIRING The terminal block (labeled TB2) is located in the control box of the machine. The table limit switch wiring is located within conduit that will connect via fittings to the pre-punched holes in the back of the control box. Replace the jumper wire (white/black) with the table limit switch wiring. See picture below.



Disconnect electrical power at the breaker or disconnect switch and tag-out in accordance with procedures and codes.



The switch is wired common and normally-open because of the hinge design. By interrupting the line in series with the door switch(es), the dishmachine ceases to operate. Refer to the schematic for details.

ELECTRICAL RATING

Volts	Amp
208	>1.0
230	>1.0

LEGEND

- CB - Control Circuit Breaker
- T1 - Control Transformer
- S1 - Power Switch
- S2 - Door Safety Switch
- R7 - Door Safety Switch Relay
- TLS - Table Limit Switch

