

Project _____
 Item _____
 Quantity _____
 CSI Section 11400 _____
 Approval _____
 Date _____

RackStar® Side Loader

Models

- 23" RackStar Side Loader 30" RackStar Side Loader

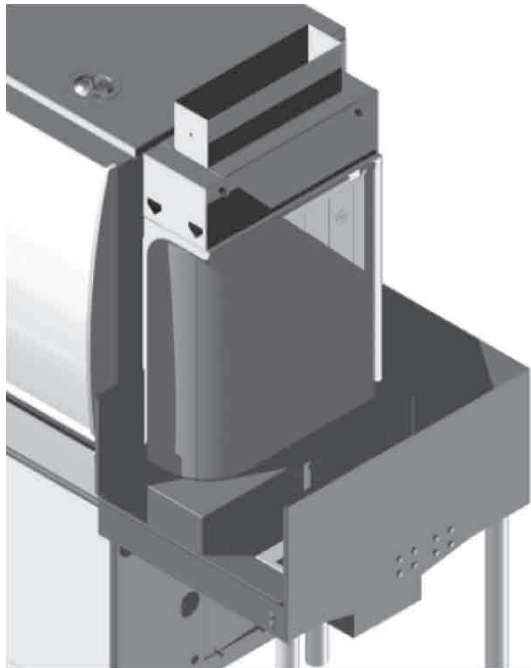

Features

Our RackStar Side Loader enhances efficiency while reducing space requirements of a dish room operation that has minimal space for a soiled table. By properly locating the dishmachine with the side loader, a savings of 16 square feet or more can be realized.

The RackStar Side Loader does not require additional electrical or mechanical devices which could create operational or maintenance problems. The drive mechanism is powered by the conveyor drive motor on the dishmachine. An extension on the pawl bar provides the drive to push the racks into the unit.

Since the RackStar Side Loader is shipped mounted on the RackStar Conveyor Dishmachine, there is no additional installation required for this option. As it is operated mechanically by the dishmachine, it does not require any plumbing or electrical connections.

Specifications

DESIGN: This is a factory installed option which will convert the RackStar Conveyor Dishmachine to a corner operation. It will add 23" or 30" to the overall width of the unit.

CONSTRUCTION: Bottom, including sump, back and sides are formed from 16 gauge No. 304 polished stainless steel with No. 3 finish. Side loader shall be bolted to the dishmachine chamber and will have standard table legs for support. Sump area to be pitched to a 1-1/2" drain centrally located. A stainless steel strainer shall cover the drain.

CONVEYOR: Adjustable stainless steel rack guides are attached to top of sump to provide support and direction to racks. Drive mechanism is an extension of the pawl bar and contains three pawls to push the rack into the unit.

MODEL NO.	MACHINE DIMENSIONS			SHIPPING INFORMATION					
	SIDE LOADER WIDTH	SIDE LOADER DEPTH	TOTAL MACHINE WIDTH WITH SIDE LOADER	WEIGHT	CLASS	CUBE	HEIGHT	WIDTH	DEPTH
RackStar® 44 with 23" Side Loader	23" (584 mm)	29" (737 mm)	67" (1702 mm)	980 lbs (445 kg)	92.5	204.83 cu. ft.	89" (2261 mm)	97" (2464 mm)	41" (1041 mm)
RackStar® 66 with 23" Side Loader	23" (584 mm)	29" (737 mm)	89" (2261 mm)	1329 lbs (603 kg)	92.5	299.86 cu. ft.	89" (2261 mm)	142" (3607 mm)	41" (1041 mm)
RackStar® 44 with 30" Side Loader	30" (762 mm)	29" (737 mm)	74" (1880 mm)	990 lbs (449 kg)	92.5	204.83 cu. ft.	89" (2261 mm)	97" (2464 mm)	41" (1041 mm)
RackStar® 66 with 30" Side Loader	30" (762 mm)	29" (737 mm)	96" (2439 mm)	1339 lbs (607 kg)	92.5	299.86 cu. ft.	89" (2261 mm)	142" (3607 mm)	41" (1041 mm)

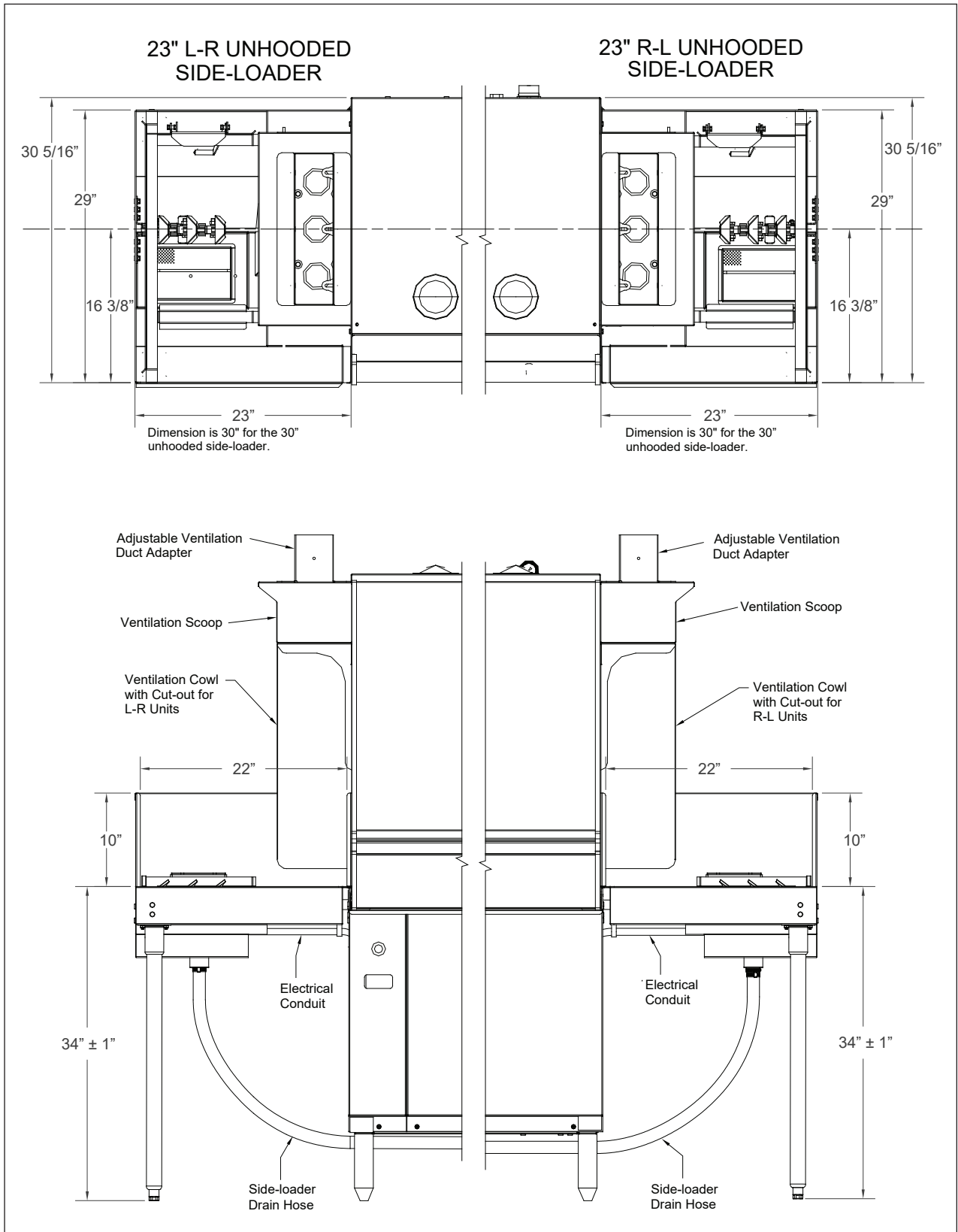

Jackson WWS, Inc.

Shipping Address: 6209 North U.S. Highway 25E, Gray, KY 40734
 Mailing Address: P.O. Box 1060, Barbourville, KY 40906
 Telephone: 888-800-5672 • Fax: 606-523-1799
 Email: customer.service@jacksonwws.com
 07610-003-90-33 [04/23/2020]

www.jacksonwws.com