

AJX-80

Project _____
 Item _____
 Quantity _____
 CSI Section 11400
 Approval _____
 Date _____

AJX-80

Models

AJX-80



Standard Features

- 25" clearance accommodates larger wares, such as sheet pans, mixing bowls, etc.
- Exclusive EnergyGuard™ controls
- Fully automatic, including auto-fill
- Electromechanical controls
- Adjust-A-Peak™ adjustable conveyor speed allows machine to extend wash time and rinse contact for heavy soil conditions
- Self-draining stainless steel wash pump
- Stainless steel scrap baskets
- Splash shields
- Front dress panel
- Externally operated drain lever
- Adjustable bullet feet
- Stainless steel frame and legs
- Exhaust vent fan control
- 18kW wash tank heater

Mandatory Specs

Specify:

- Electric Steam

Specify Voltage _____

Specify Sanitizing Method:

- High Temperature
 Chemical Sanitizing

Specify Direction of Operation:

- Left to Right
 Right to Left

Options & Accessories

- Booster Heater
 - 40° F (22.2° C) Rise - 17kW
 - 70° F (38.9° C) Rise - 30kW
- Steam Booster Heater
- 23" (584 mm) Unhooded Side Loader
- 23" (584 mm) Hooded Side Loader
- 30" (762 mm) Unhooded Side Loader
- 30" (762 mm) Hooded Side Loader
- 1/2" Pressure Regulator
- Flanged Feet
- Blower Dryer
- Vent Cowl Collars (set of 2)
- Prison Package
- Drain Quench System
- Scaltrol
- Water Hammer Arrestor
- Strikeplate Table Limit Switch
- 36-Compartment Rack
 - 4-1/8" tall (105 mm)
 - 5 - 5/8" tall (143 mm)
 - 7" tall (178 mm)
- Combination Rack
- Peg Rack
- Sheet Pan Rack

Specifications

High-temperature model uses 0.68 gallons (2.57 liters) per rack. Chemical-sanitizing model uses 0.78 gallons (2.95 liters) per rack

High-temperature model cleans 225 racks per hour. Chemical-sanitizing model cleans 209 racks per hour

36" (915 mm) pre-wash section has 3 upper and 2 lower pre-wash arms

8" (203 mm) splash shields on both wash and rinse ends

25" (635 mm) chamber height clearance accommodates larger wares

18" (457 mm) wash section with an 18" (457 mm) separation between wash and rinse

Durable stainless steel construction



Intertek

AJX-80

Left to Right

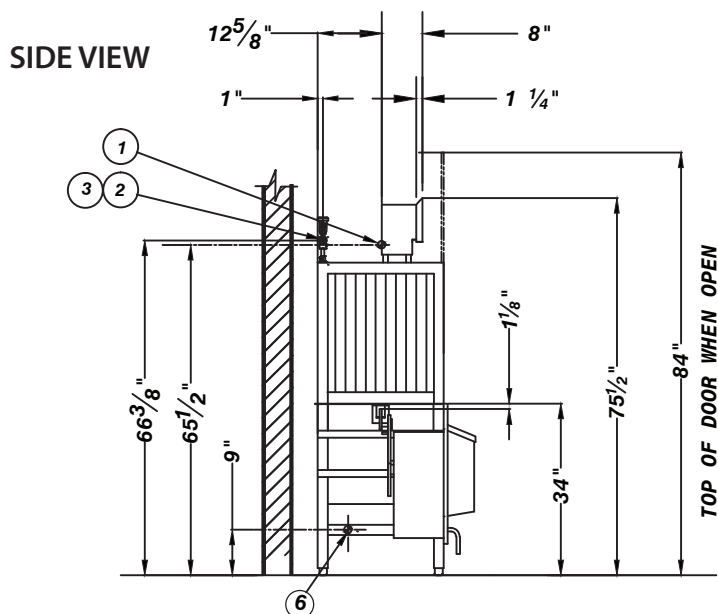
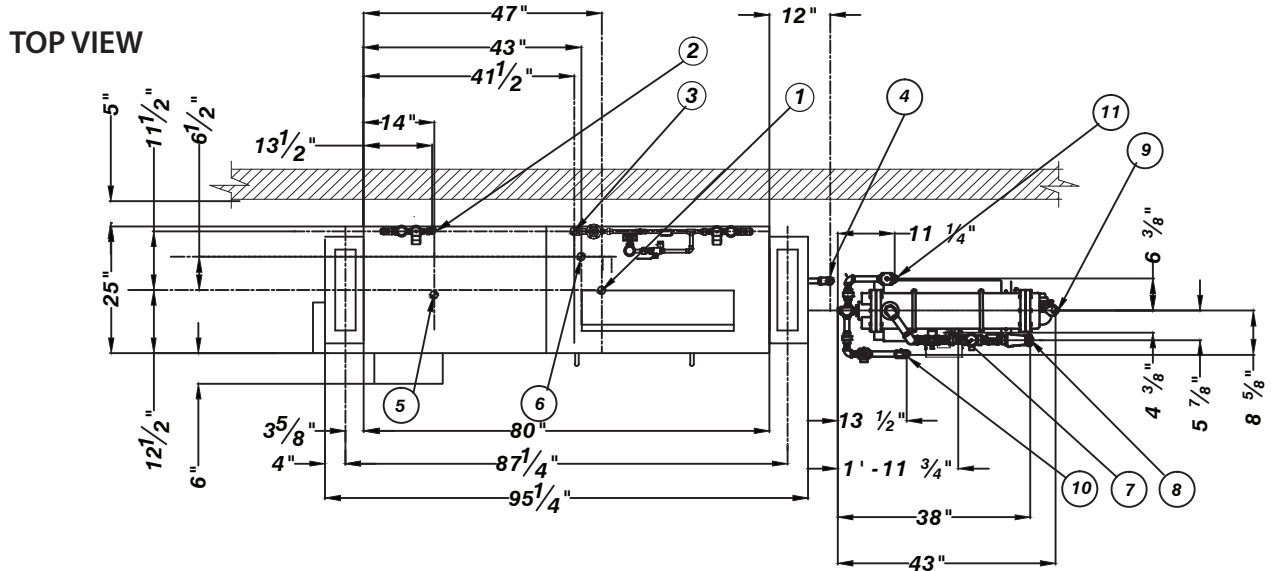
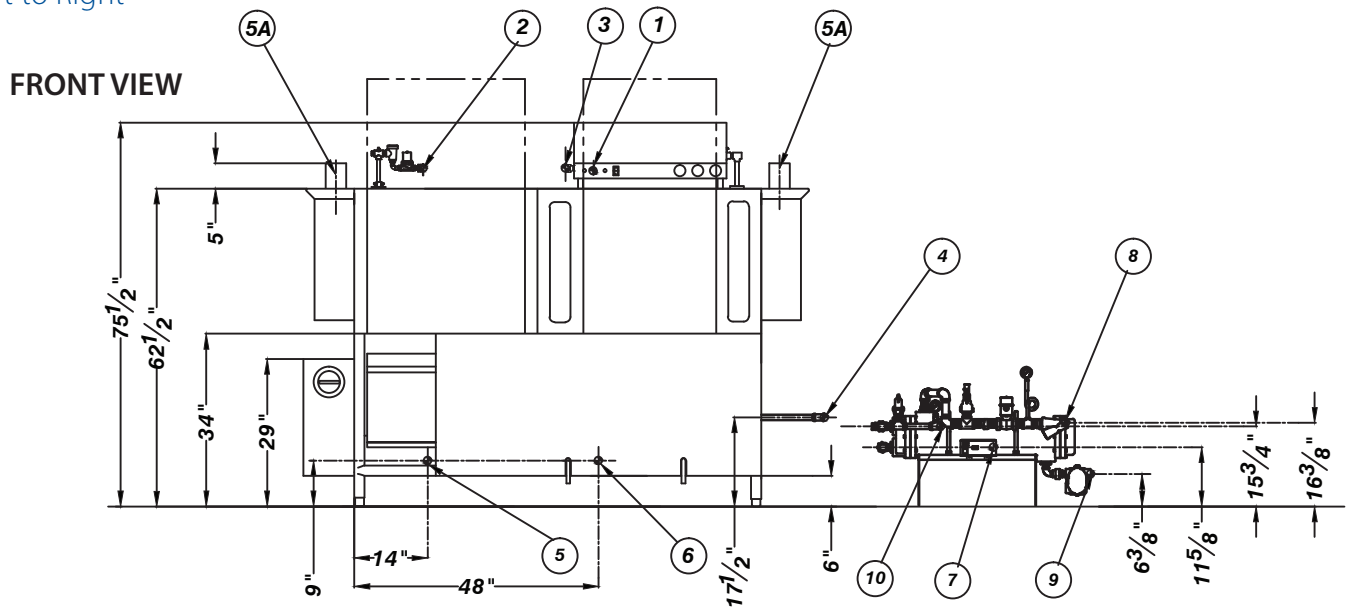

1. Electrical connection
2. 1/2" NPT 110-140° F water inlet for pre-wash
3. 1/2" NPT 180° F water inlet for wash and final rinse
4. 3/4" NPT steam connection
5. 3/4" NPT condensate return line
- 5a. Vent connection - Includes damper. 2 locations 4" I.D. X 16" I.D.
6. 1-1/2" NPT drain connection

STEAM BOOSTER CONNECTIONS

7. Electrical connection
8. 1" NPT steam connection
9. 3/4" NPT condensate connection
10. 3/4" NPT incoming 110° F water connection
11. 3/4" NPT 180° water connection to dishmachine

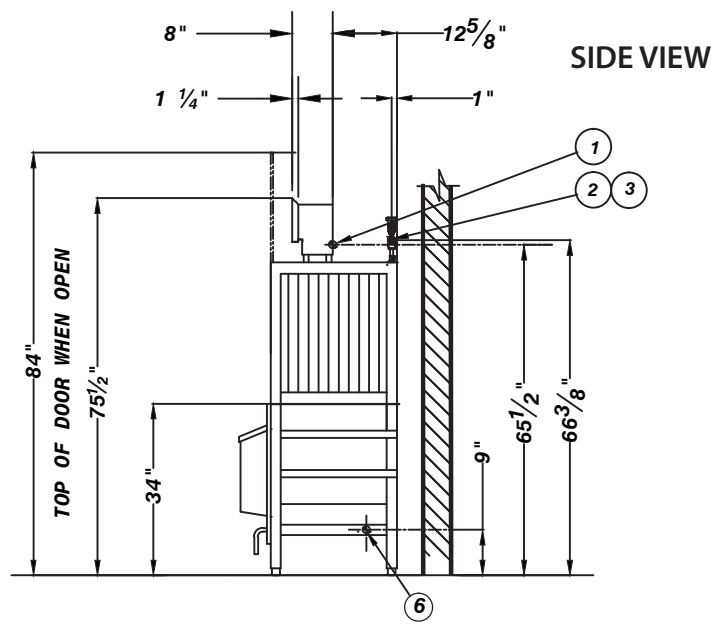
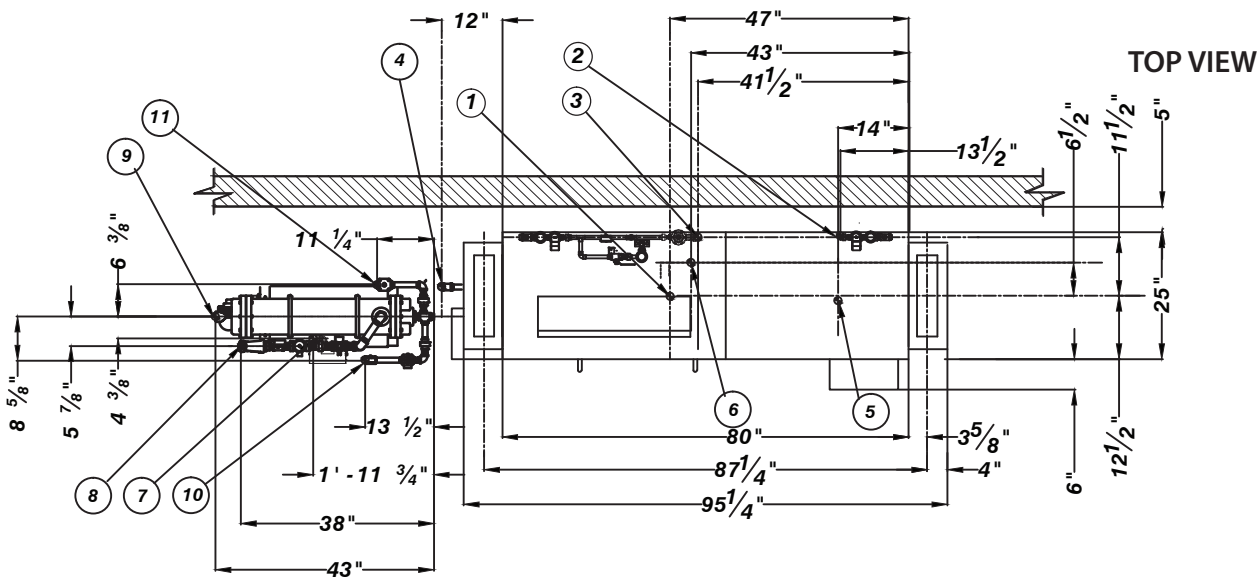
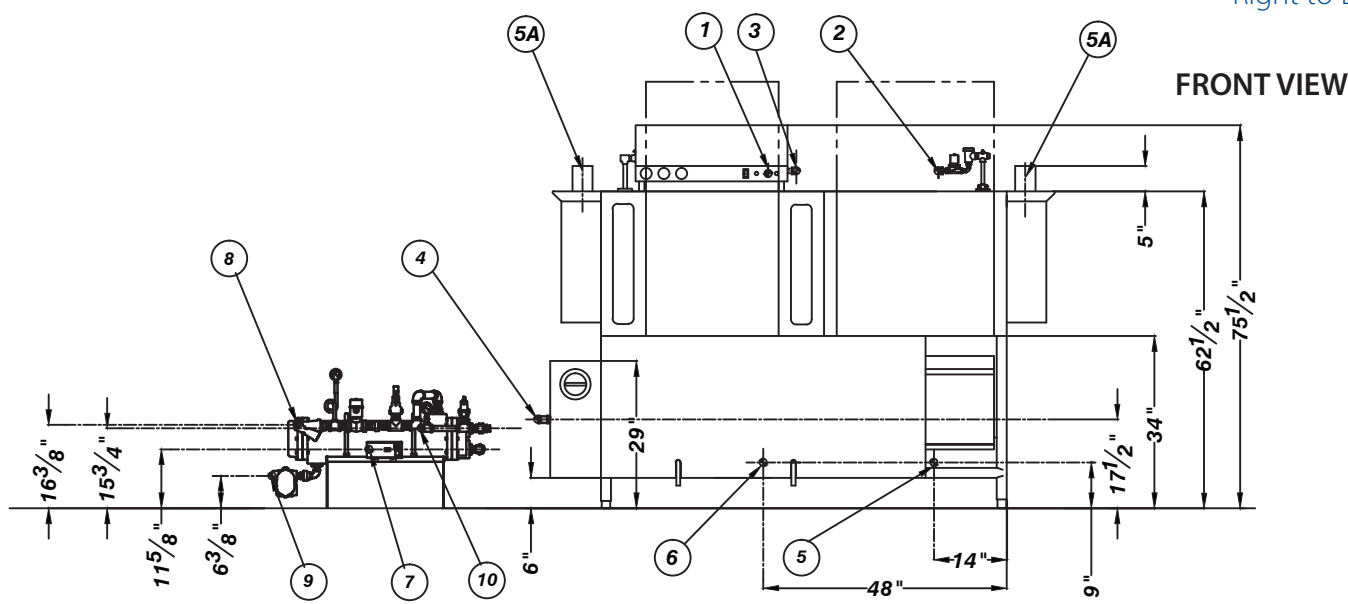

- 1. Electrical connection
- 2. 1/2" NPT 110-140° F water inlet for pre-wash
- 3. 1/2" NPT 180° F water inlet for wash and final rinse
- 4. 3/4" NPT steam connection
- 5. 3/4" NPT condensate return line
- 5a. Vent connection - Includes damper. 2 locations 4" I.D. X 16" I.D.
- 6. 1-1/2" NPT drain connection

STEAM BOOSTER CONNECTIONS

- 7. Electrical connection
- 8. 1" NPT steam connection
- 9. 3/4" NPT condensate connection
- 10. 3/4" NPT incoming 110° F water connection
- 11. 3/4" NPT 180° water connection to dishwasher

Recommended Table Fabrication

Note: Tub Will Accept a Table Flange Up to 24 7/8" (632 mm)

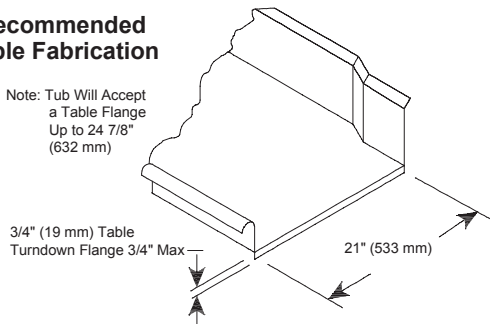
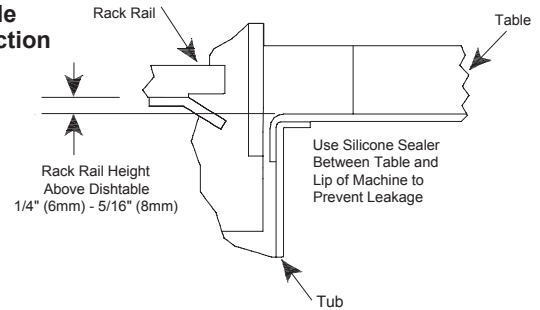

Table Connection



MODEL NO.	MACHINE DIMENSIONS				DRAIN HEIGHT	SHIPPING INFORMATION					
	HEIGHT	HEIGHT WITH DOOR OPEN	LENGTH BETWEEN DISHTABLES	DEPTH		WEIGHT	CLASS	CUBE	HEIGHT	WIDTH	DEPTH
AJX-80	75-1/2" (1919 mm)	84" (2134 mm)	80" (2032 mm)	31" (787 mm)	10-1/4" (260 mm)	1025 lbs (465 kg)	250	198.61 cu. ft.	78" (1982 mm)	110" (2794 mm)	40" (1016 mm)

DIMENSION REQUIREMENTS

Wall Clearance (minimum)	4-1/2" (114 mm)
Standard Table Height	34" (864 mm)
Inside Clearance	25" (635 mm)

OPERATING CAPACITY

	High-Temperature	Chemical Sanitizing
Racks per Hour	225	209

OPERATING TEMPERATURES

	High-Temperature	Chemical Sanitizing
Pre-Wash Tank	110-140°F (43-60°C)	110-140°F (43-60°C)
Wash (minimum)	160° F (71° C)	140° F (60° C)
Rinse (minimum)	180° F (82° C)	140° F (60° C)

ELECTRICAL REQUIREMENTS

	Approximate Total Load AMPS	
	Electric	Steam
208V/60HZ/3PH	62.3	12.3
208V/60HZ/1PH	105.3	18.8
230V/60HZ/3PH	57.5	12.3
230V/60HZ/1PH	97.1	18.8
460V/60HZ/3PH	28.8	6.2

BOOSTER HEATER OPTIONS

	40° F (22.2° C) Minimum Rise		70° F (38.9° C) Minimum Rise	
	kW	AMPS	kW	AMPS
208V/60HZ/3PH	17.2	47.8	30	83.4
230V/60HZ/3PH	18	45.2	30	75.4
460V/60HZ/3PH	18	22.6	30	37.7

HOW TO SPECIFY: AJX-80

WATER REQUIREMENTS

Inlet Temperature (minimum)	
With 40° F (22.2° C) Rise Booster Heater	140° F (60° C)
With 70° F (38.9° C) Rise Booster Heater	110° F (43° C)
Gallons per Hour - High-Temperature	153 gal (579 L)
Gallons per Hour - Chemical Sanitizing	163 gal (617 L)
Gallons per Rack - High-Temperature	.68 gal (2.6 L)
Gallons per Rack - Chemical Sanitizing	.78 gal (3.0 L)
Waterline Size IPS (minimum)	1/2"
Drainline Size IPS (minimum)	1-1/2"
Flow Pressure (PSI)	15
Flow Rate (minimum) - High -Temperature	2.6 GPM (9.8 LPM)
Flow Rate (minimum) - Chemical Sanitizing	2.7 GPM (10.2 LPM)
Pre-Wash Tank Capacity	17.25 gal (65.3 L)
Wash Tank Capacity	21 gal (79.5 L)

PUMP MOTORS

Pre-Wash Pump Motor	2 hp
Wash Pump Motor	2 hp
Pre-Wash Pump Capacity	270 GPM (1022 LPM)
Wash Pump Capacity	270 GPM (1022 LPM)

CONVEYOR

Conveyor Motor	1/4 hp
Conveyor Speed (feet per minute highest speed)	
High-Temperature	6.2 FPM (1.9 MPM)
Chemical Sanitizing	5.75 FPM (1.75 MPM)

VENTING REQUIREMENTS

	Input End	Output End	Total CFM
	200 CFM	400 CFM	600 CFM

STEAM COIL TANK HEAT (STEAM MODELS ONLY)

Steam Connection IPS	3/4"
Steam Flow Pressure (PSIG)	10-20
Consumption @ 15 PSIG (lbs/hr)	60

Jackson WWS, Inc.

Shipping Address: 6209 North U.S. Highway 25E, Gray, KY 40734
 Mailing Address: P.O. Box 1060, Barbourville, KY 40906
 Telephone: 888-800-5672 • Fax: 606-523-1799
 Email: info@jacksonwws.com
 07610-003-78-23 [03/02/17]

www.jacksonwws.com