

CONSERVER XL-E-LTH WF-I-E-LTH SCHEMATIC

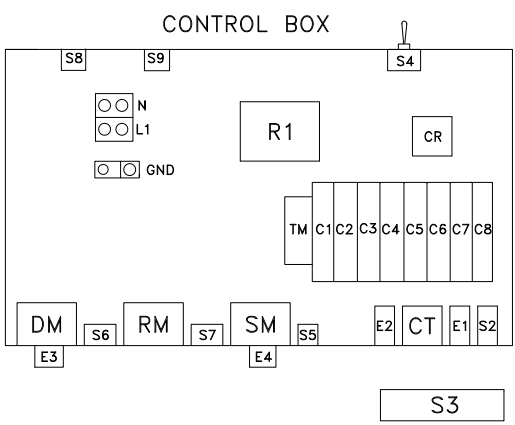
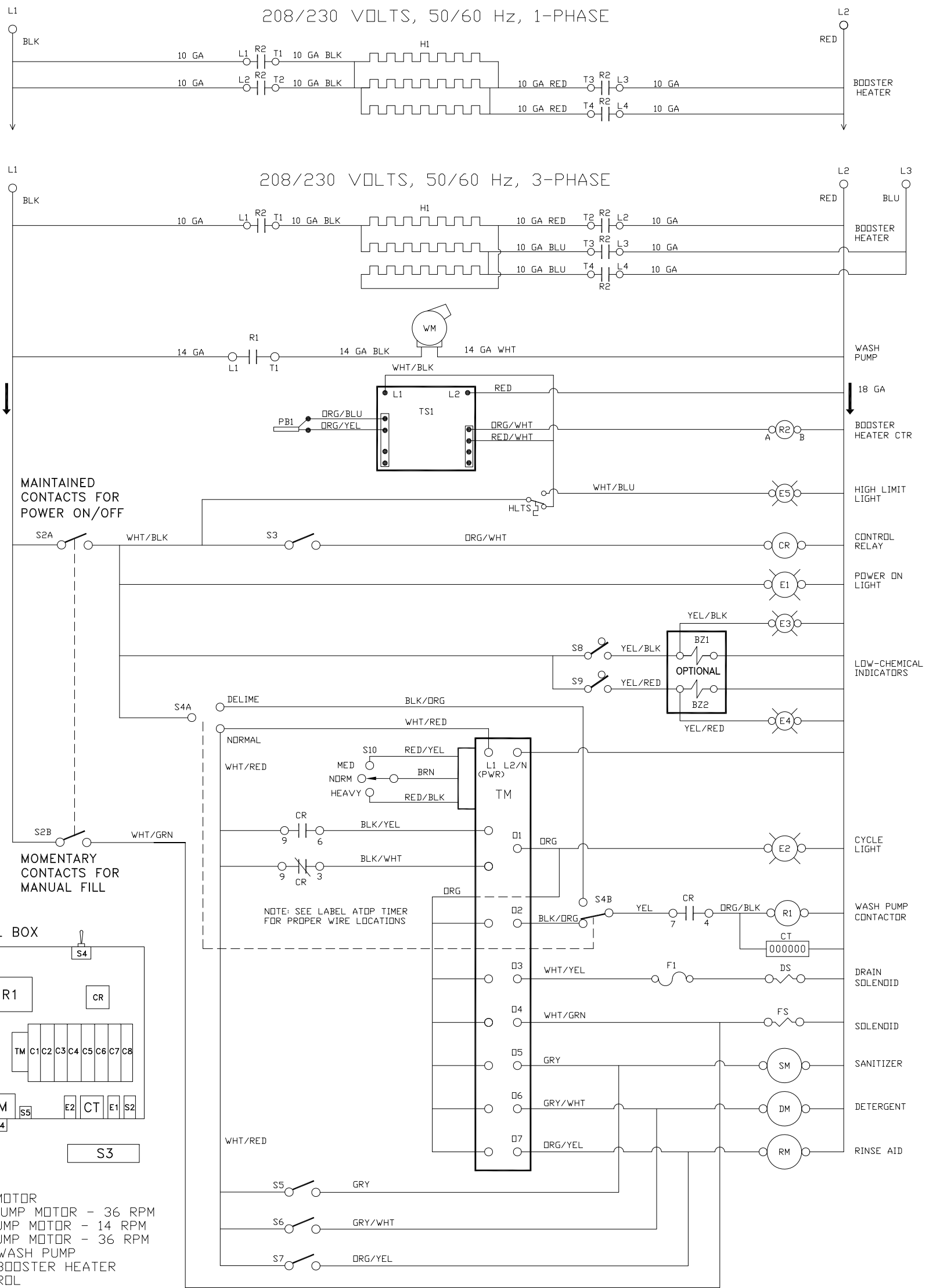

- LEGEND**
- WM WASH PUMP MOTOR
 - DM DETERGENT PUMP MOTOR - 36 RPM
 - RM RINSE-AID PUMP MOTOR - 14 RPM
 - SM SANITIZER PUMP MOTOR - 36 RPM
 - R1 CONTACTOR, WASH PUMP
 - R2 CONTACTOR, BOOSTER HEATER
 - CR RELAY, CONTROL
 - S2 SWITCH, OFF/DN/FILL
 - S3 SWITCH, DOOR
 - S4 SWITCH, NORMAL/DELIME
 - S5 SWITCH, SANITIZER PRIME
 - S6 SWITCH, DETERGENT PRIME
 - S7 SWITCH, RINSE AID PRIME
 - S8 SWITCH, DETERGENT VACUUM
 - S9 SWITCH, SANITIZER VACUUM
 - S10 SWITCH, CYCLE SELECT
 - TS1 THERMOSTAT, BOOSTER HEATER
 - HTLS HIGH-LIMIT, BOOSTER HEATER
 - PB1 PROBE, BOOSTER TEMPERATURE
 - E1 LIGHT, POWER
 - E2 LIGHT, CYCLE
 - E3 LIGHT, DETERGENT
 - E4 LIGHT, SANITIZER
 - E5 LIGHT, BOOSTER HIGH-LIMIT
 - DS DRAIN SOLENOID
 - FS FILL SOLENOID
 - F1 DRAIN SOLENOID FUSE 1AMP
 - TM TIMER (CYCLE)
 - CT CYCLE COUNTER
 - O1 OUTPUT, CYCLE LIGHT
 - O2 OUTPUT, PUMP (WASH/RINSE)
 - O3 OUTPUT, DRAIN
 - O4 OUTPUT, FILL
 - O5 OUTPUT, SANITIZER
 - O6 OUTPUT, DETERGENT
 - O7 OUTPUT, RINSE AID
 - BZ1 BUZZER, DETERGENT
 - BZ2 BUZZER, SANITIZER

CYCLE TIMING

STEP	WASH	DETER	DRAIN	FILL	RINSE AID	SANI	RINSE
START TIME	0.00	1.50	42.00	57.00	58.25	58.25	65.00
DURATION	42.00	5.00	14.75	8.00	4.25	5.00	25.00