

# CONSERVER XL-E/XL HH WF I-E/I-HH SCHEMATIC

208/230 VOLTS, 50/60 Hz, 1-PHASE

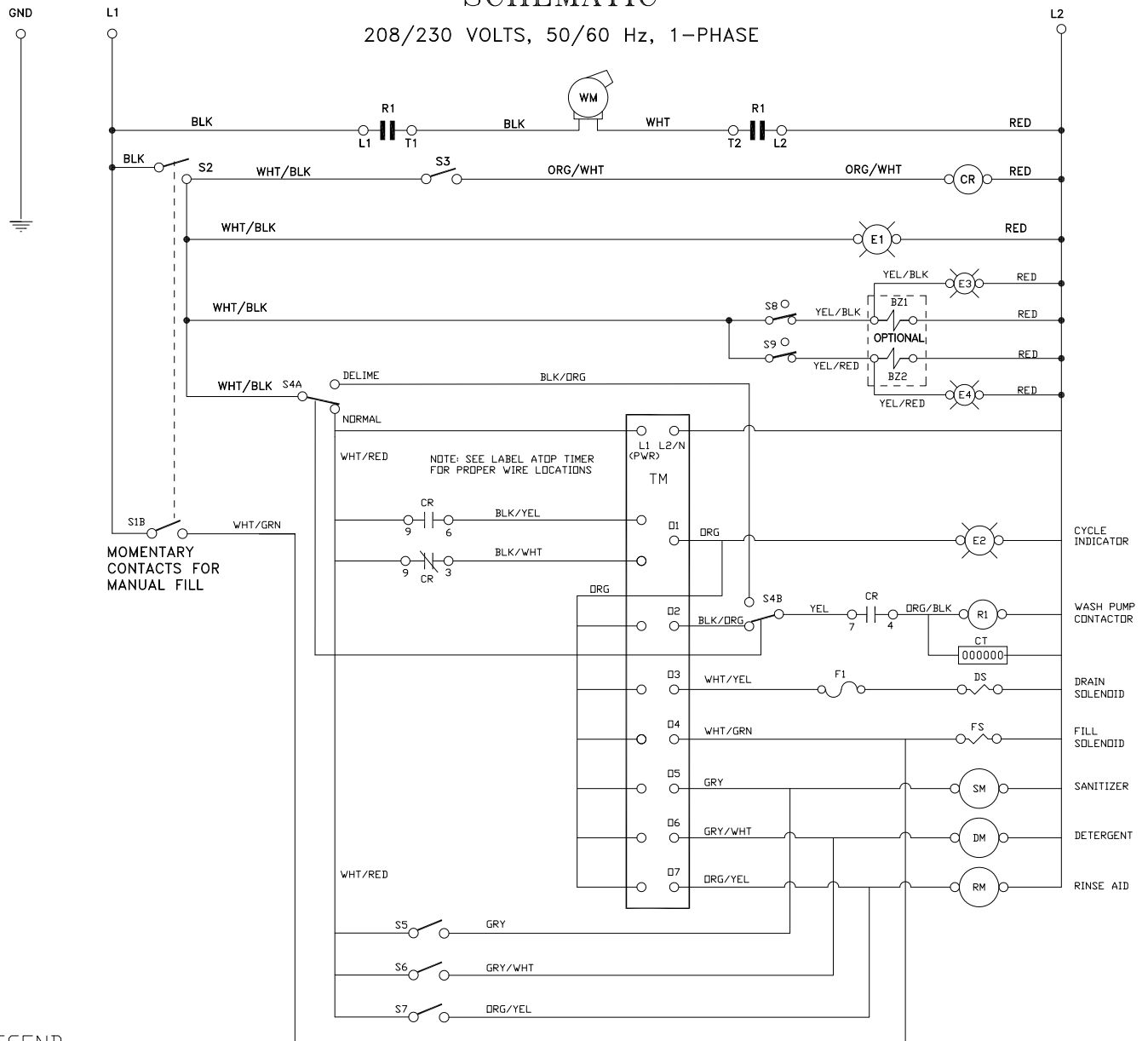

## LEGEND

- WM WASH PUMP MOTOR
- DM DETERGENT PUMP MOTOR - 36 RPM
- RM RINSE-AID PUMP MOTOR - 14 RPM
- SM SANITIZER PUMP MOTOR - 36 RPM
- R1 CONTACTOR, WASH PUMP
- CR RELAY, CONTROL
- S1 SWITCH, OFF/ON/FILL
- S2 SWITCH, DOOR
- S4 SWITCH, NORMAL/DELIME
- S5 SWITCH, SANITIZER PRIME
- S6 SWITCH, DETERGENT PRIME
- S7 SWITCH, RINSE AID PRIME
- S8 SWITCH, DETERGENT VACUUM
- S9 SWITCH, SANITIZER VACUUM
- E1 INDICATOR, POWER ON
- E2 INDICATOR, CYCLE
- E3 INDICATOR, DETERGENT
- E4 INDICATOR, SANITIZER
- DS DRAIN SOLENOID
- FS FILL SOLENOID
- F1 DRAIN SOLENOID FUSE 1AMP
- TM TIMER (CYCLE)
- CT CYCLE COUNTER
- O1 OUTPUT, CYCLE INDICATOR
- O2 OUTPUT, PUMP (WASH/RINSE)
- O3 OUTPUT, DRAIN
- O4 OUTPUT, FILL
- O5 OUTPUT, SANITIZER
- O6 OUTPUT, DETERGENT
- O7 OUTPUT, RINSE AID
- BZ1 BUZZER, DETERGENT
- BZ2 BUZZER, SANITIZER
- SPL SPLICE

## CONTROL BOX

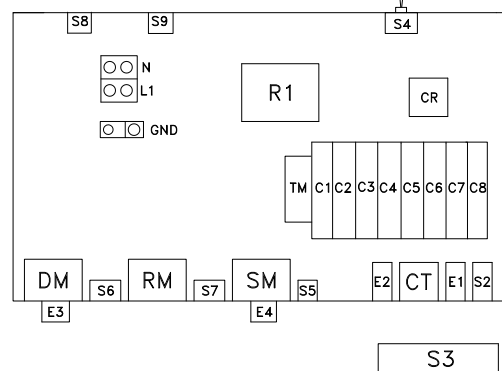

## CYCLE TIMING

STEP	WASH	DETER	DRAIN	FILL	RINSE AID	SANI	RINSE
START TIME	0.00	1.50	42.00	57.00	58.25	58.25	65.00
DURATION	42.00	5.00	14.75	8.00	4.25	5.00	25.00